

The Wireless World

THE
PRACTICAL RADIO
JOURNAL
25th Year of Publication

No. 840.

FRIDAY, OCTOBER 4TH, 1935.

VOL. XXXVII.

No. 14.

Proprietors : ILIFFE & SONS LTD.

Editor :
HUGH S. POCOCK.

Editorial,
Advertising and Publishing Offices :
DORSET HOUSE, STAMFORD STREET,
LONDON, S.E.1.

Telephone: Hop 3333 (50 lines).
Telegrams: "Ethaworld, Sedist, London."

COVENTRY: Hertford Street.
Telegrams: "Autocar, Coventry." Telephone: 5210 Coventry.

BIRMINGHAM:
Guildhall Buildings, Navigation Street, 2.
Telegrams: "Autopress, Birmingham." Telephone: 2971 Midland (4 lines).

MANCHESTER: 260, Deansgate, 3.
Telegrams: "Iliffe, Manchester." Telephone: Blackfriars 4412 (4 lines).

GLASGOW: 26B, Renfield Street, C.2.
Telegrams: "Iliffe, Glasgow." Telephone: Central 4857.

PUBLISHED WEEKLY. ENTERED AS SECOND
CLASS MATTER AT NEW YORK, N.Y.

Subscription Rates :
Home, £1 1s. 8d. ; Canada, £1 1s. 8d. ; other
countries, £1 3s. 10d. per annum.

*As many of the circuits and apparatus described in these
pages are covered by patents, readers are advised, before
making use of them, to satisfy themselves that they would
not be infringing patents.*

CONTENTS

	Page
Editorial Comment	361
1936 Battery Monodial Super ..	362
New Time Base Circuit	367
The Development of the Wireless Aerial II	368
Current Topics	370
Television Transmissions ..	371
Contrast Expansion	374
New Apparatus Reviewed ..	375
Broadcast Brevities	376
Automatic Selectivity Control ..	377
Listeners' Guide for the Week ..	378
Murphy A28C Receiver Reviewed	380
Letters to the Editor	382
Random Radiations	384
Principal Broadcasting Stations..	385

EDITORIAL COMMENT

The Second-hand Receiver

An Attempt to Meet a Real Need

HOW often do listeners change their sets? Unless they can afford to disregard a considerable capital loss, circumstances dictate that they do not often do so.

This state of affairs exists in wireless to-day because a second-hand wireless set is so difficult to dispose of at a fair price, with the result that owners are inclined to hold on to their sets as long as the sets will hold together, instead of being able to enjoy the advantages, both in performance and appearance, which the more modern sets offer.

Reception conditions and set design had not stabilised sufficiently until two or three years ago to make second-hand sets of marketable value, and later when suitable sets have been available, there has been no recognised medium for offering them for sale.

An Opportunity

The *Wireless World* hopes to overcome these difficulties and facilitate the disposal of second-hand sets at a price which will enable the owner to purchase a new receiver without feeling that he has been extravagant, whilst the purchaser of his set will, in many cases, become for the first time the owner of an effective receiver at a price he can afford.

We believe it to be essential, if the disposal of second-hand sets is to be effective, that there should be one recognised medium where all such sets should be advertised either "for sale" or "wanted." In this way the fullest opportunity will be presented both to the seller and to the purchaser.

With this object in view we are publishing amongst the advertisement pages in this issue a coupon which entitles any reader to a free advertisement, to enable him to offer for sale his present receiver, the disposal of which will enable him to invest in something more up-to-date.

We ask our readers to make use of these coupons because we are particularly anxious that the scheme should meet with success at the outset. It will, we believe, then grow to serve a most useful purpose to our readers, the general public, and the radio industry.

Television

Basic Details Disclosed

IN this issue we publish statements which have been sent to us by Baird's and by Marconi-E.M.I. with a request that we should give publication to them for the benefit of those who wish to have, in advance, information as to the nature of the television transmissions. It will be remembered that programmes are to be radiated from both these companies' transmitters when they are, in due course, taken over by the B.B.C.

Those who have already studied the subject of television sufficiently will find that this information, although scanty, does give the first essential material on which the design of receivers can be based. It is not, however, the whole story and manufacturers and experimenters will find plenty of scope for individual effort in developing receiving sets.

As time goes on and we approach nearer to the date of the commencement of transmissions, it is to be hoped that fuller technical information will become available.

Constructing and
Operating the New
Sensitive High-Quality
Receiver

The 1936 Battery

By W. T. COCKING

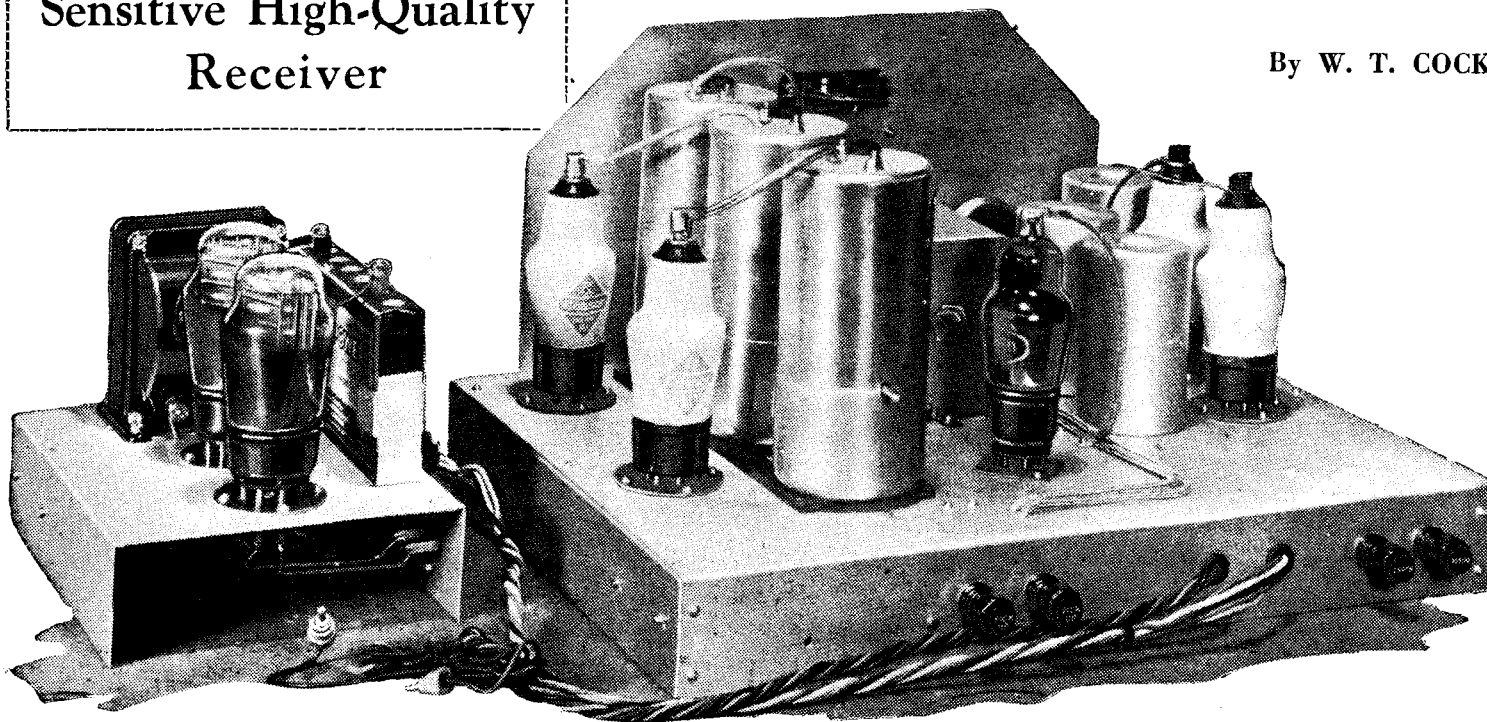

FACTORS which governed the design of this new superheterodyne were discussed fully in last week's issue, and in this article the construction is dealt with. The adjustments necessary for the attainment of the best performance are also described.

THE components of the 1936 Battery Monodial are assembled on an aluminium chassis which can be obtained ready drilled. There are few points of special importance to observe in the assembly, and the parts may be mounted in any order. Wires should, however, be attached to the gang condenser before it is mounted, for when it is in position the soldering tags are obscured by the IF transformers. These transformers are spaced slightly from the chassis by two wooden battens, not to provide insulation but to obtain a firm seating on the chassis. Care should be taken to see that there is a good contact between the chassis and the frame of the gang condenser, and all screening cans.

The wiring must be carefully carried out to ensure that not only are all connections made, and made correctly, but that unwanted couplings are not introduced. With this end in view it is insufficient merely to connect the correct points together, for the wires themselves must be as carefully placed relative to one another as the components. The physical disposition of the wiring shown in the drawings and photographs must, therefore, be carefully followed.

The valve anodes require a supply of some 120 volts, and the screens of the early valves about 80 volts. A single cell in the receiver provides grid bias for the early stages, but the bias for the output stage is derived from a separate battery

in that unit. The exact bias used here should be found experimentally; in general, the best quality will be obtained with six volts, but greater economy of HT current can be obtained with a somewhat higher bias.

Ganging with a Test Oscillator

Before the receiver will function correctly, the initial adjustments must be made. These can be divided into three sections: the IF trimming, the medium-wave ganging, and the long-wave ganging. If a calibrated test oscillator be available, set it to 465 kc/s and connect its output between the grid of the second IF transformer and the chassis. Adjust the two trimmers on the third IF transformer (rear can) for maximum response, with the selectivity control set towards high selectivity, that is, with the control nearly fully rotated in an anti-clockwise direction. Then transfer the oscillator output to the first IF valve, connecting it between the grid and the AVC line, and adjust the two trimmers on the second transformer. The trimmers on the first transformer (front can) are similarly adjusted with the oscillator joined between the grid of the heptode and the AVC line. The tuning indicator provides a ready means of determining the optimum setting of each trimmer, for if the oscillator output be adequate there will be a marked change in the reading at resonance, except in the

case of one circuit in the last transformer, which must be trimmed by ear. Keeping the oscillator connected to the frequency-changer, check the adjustment of each circuit, and it will usually be found that the optimum settings have changed very slightly.

The oscillator should now be connected to the aerial and earth terminals and set at 1,400 kc/s. Stop the oscillator from working by joining terminal (1) of the oscillator coil directly to the chassis, and set the waverange switch for the medium waveband. Set the oscillator to give a large output (0.1 to 1 volt), and tune in the signal by the main tuning control. Nothing will be heard, of course, for the oscillator is not functioning, but an indication should be found on the tuning meter. Having found the optimum setting, adjust the trimmers on the rear and middle sections of the gang condenser for maximum response. The trimmer on the rear section should be nearly fully unscrewed.

Next remove the short-circuit from the oscillator coil, reduce the output of the test oscillator and adjust the oscillator trimmer (front section of the gang condenser) for maximum response. The setting of this trimmer is very critical. The test oscillator should now be set at 600 kc/s and adjusted for large output. The short-circuit should be applied to the oscillator in the set and the set tuned to 600 kc/s by means of the main tuning

Monodial Super

control, using the tuning meter as an indicator. Remove the short-circuit, reduce the oscillator output, and adjust C8 for maximum response. A readjustment of the ganging at 1,400 kc/s should now be made in the manner already described, and the medium-wave ganging is complete.

The procedure on the long-wave band is identical with that on the medium, save that the trimmers on the gang condenser must not be touched. The test frequencies are now 300 kc/s and 160 kc/s, and the oscillator should first be set to the former with large output and terminal (1) of the oscillator coil shorted to the chassis. The signal should be tuned in, the oscillator output reduced, the short

removed, and C12 adjusted. At 160 kc/s the same procedure should be adopted, but here C13 is adjusted.

If a test oscillator is not available, the adjustments are somewhat more difficult to carry out, but not unduly so. The procedure, however, is rather different. The first step is to screw each IF trimmer fully home and then to unscrew each one and one-half turns. The circuits are then roughly tuned to 465 kc/s. Set the selectivity control at minimum selectivity, unscrew the trimmer on C3 nearly fully, that on C6 about half-way, and that on C9 about two-thirds. It should now be possible to find some signal and this should be used for the adjustment of the IF cir-

cuits. At first adjust each IF trimmer roughly. This will probably lead to a big increase of signal strength, and the selectivity can be increased. Retuning on the main control will probably be needed, and the selectivity should be increased as much as possible while keeping the signal audible. Each IF trimmer can then be accurately adjusted for maximum signal strength, using the tuning meter as an indicator if possible. It should now be possible to receive plenty of stations and only the ganging requires adjustment.

Ganging on a Signal

Find a station on as low a wavelength as possible, and adjust the trimmers on C3 and C6 for maximum response. C3 should be nearly fully unscrewed; if it is not, alter the setting of the tuning control appropriately, and retune the same station by adjusting all three trimmers on the gang condenser. Thus, suppose that no optimum setting can be found for C3, but that results are best with it fully un-

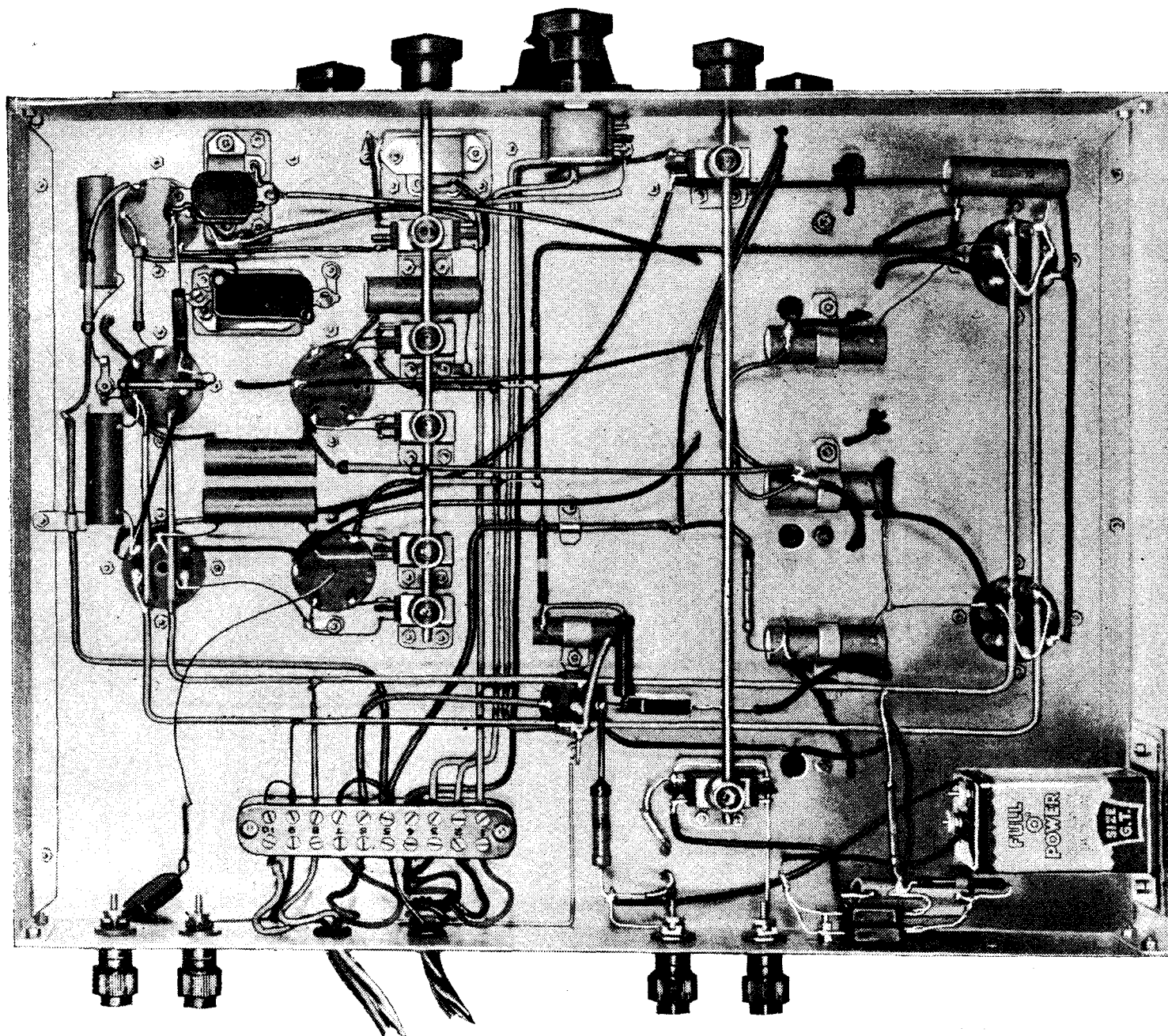

The wiring and chief underbase components are clearly shown in this illustration. Note the single dry-cell for grid bias;

PRACTICAL WIRING DIAGRAM

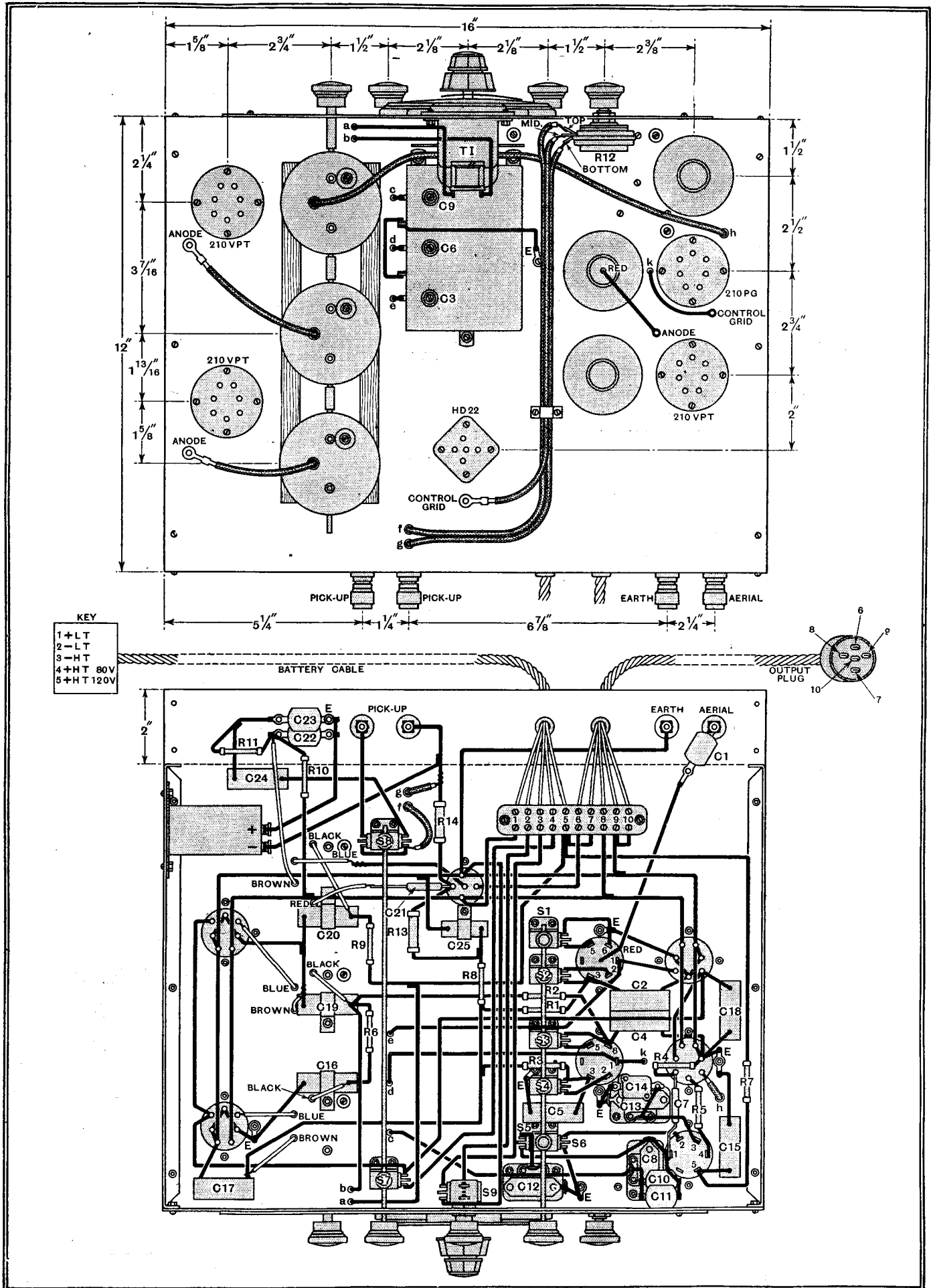

Full details of the layout of components and the wiring are given in these drawings.

The 1936 Battery Monodial Super—
screwed. This means that the capacity across this circuit is too great. Consequently, the tuning control should be set two or three degrees lower and the station retuned by increasing the capacity of all three trimmers.

When satisfied with the adjustment at this point, tune in a station at the other

with little or no interference when the selectivity control is set for high selectivity. The exceptions are those cases where stations are spaced less than the regulation 9 kc/s, and those stations which are immediately adjacent to a powerful local. When the selectivity approaches its maximum it is of a high order, as is attested by the fact that no

A full-size blue print of the combined wiring diagrams of the receiver and power units is available from the Publishers, Dorset House, Stamford Street, London, S.E.1 Price 1s. 6d. post free.

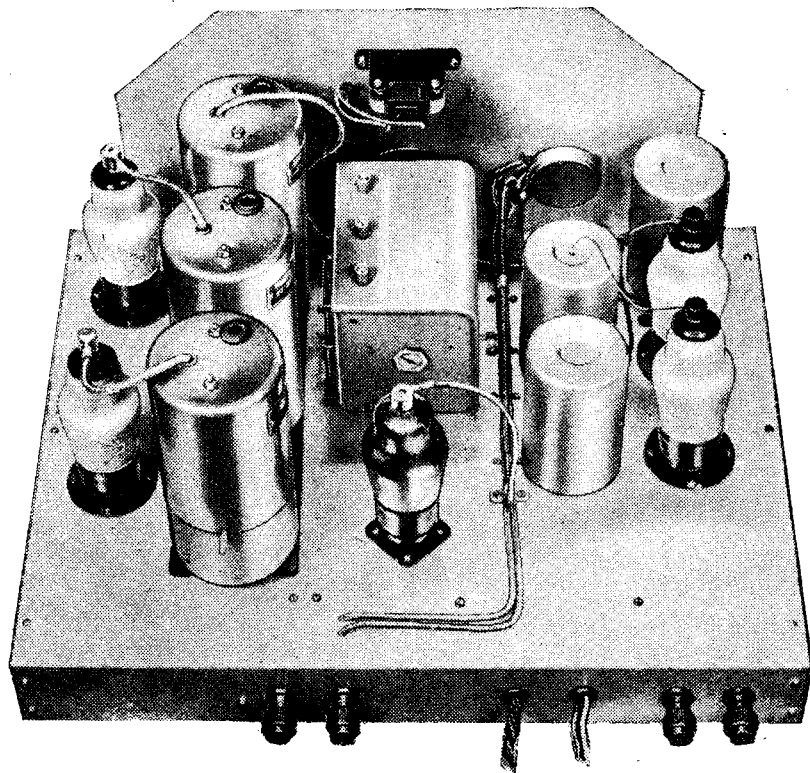

This view of the receiver shows the chief components on the upper side of the chassis. The frequency-changer and preselector are on the right.

end of the waveband and adjust C8 while rocking the main control backwards and forwards until the optimum combination of settings be found. Some slight re-adjustment of C3 and C6 at a low wavelength may then be necessary.

The long waveband trimming is next in order. Set C13 at about the middle of its travel, and the tuning control to read 60 degrees. Then tune in Droitwich by adjusting C12. It should then be possible to find a station on a lower wavelength and C12 can be adjusted while rocking the main tuning control backwards and forwards until the optimum combination of settings is found. No adjustment to C13 will usually be needed.

When these initial adjustments have been made, the receiver is ready for operation, and, with certain exceptions, it should be possible to receive any station

difficulty has been found in London in receiving the Deutschlandsender without intelligible interference from either Droitwich or Radio Paris. Sideband splash naturally prevents the programme from the German station being musically enjoyable, for both its neighbours are much stronger signals. Speech is readily understandable, however.

The sensitivity on test proved adequate for the reception of the weakest stations with any reasonably efficient outdoor aerial, and ample for all the stronger transmissions with a poor indoor aerial. Such an aerial is not, of course, to be recommended, but where its use is unavoidable the set can be relied upon to give a good account of itself. Second channel interference was found to be very small indeed, while background hiss proved negligible on all but the weakest stations. Under

all ordinary conditions of use internally generated whistles should be absent, save at two points at most in the tuning range. Should more whistles be found, it is a sign that either the ganging is inaccurate or that the HF or frequency-changer valve is being over-loaded by the strong signal from a local station. This may occur in a few cases where the aerial is unusually good and where the set is used at a very short distance from a transmitter, and the remedy is to change the value of C1 to 0.0001 mfd., or even slightly smaller.

The Performance

The quality of reproduction reaches a very high standard indeed for a battery-operated receiver. When operated at low selectivity for local reception, very high fidelity indeed is secured, and although it is not as good when the selectivity is increased for distant reception, it is still as high as it is possible to obtain under these conditions. The only point in which the quality may be said to suffer in comparison with a mains set of equally good design is in the power output. Even although the output is abnormally large for a battery set, it is still somewhat below that of a mains receiver, and it can hardly be increased at reasonable cost. The maximum output varies with the HT voltage used, but is of the order of 1.5 watts for really first-class quality. If rather more distortion be permitted, over 2 watts can be obtained, and with a sensitive loud speaker this represents good volume. The distortion at such a volume level, although by no means negligible, scientifically speaking, is far less than that present in the vast majority of battery receivers in use to-day.

The AVC system is designed more to counteract fading than to maintain all

VOLTAGES AND CURRENTS.

Value.	Anode Volts.	Screen Volts.	Grid Volts.	Anode Current.	Screen Current.
HF 210 VPT	90	77.5	-1.6	mA. 2.4	mA. 1.0
FC 210 PG tet.	95	77.5	-1.6	1.1	2.5
.. osc.	90	—	—	1.85	—
1st IF 210 VPT	95	77.5	-1.6	1.75	0.7
2nd IF 210 VPT	110	77.5	0	4.1	1.25
LF HD 22	85	—	-1.6	1.2	—
Output QP21 (total for two valves)	115	115	-6.2	12.5	3.9

HT battery = 115 volts.

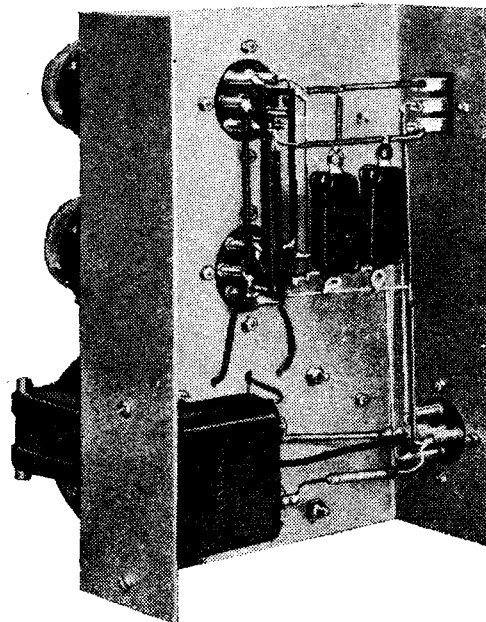

An underside view of the output unit.

1936 Battery Monodial Super—

stations at the same volume, so that no defect need be suspected if it be found that local stations are louder than others. It has been found that with the limitations imposed in practice fading reduction is

best achieved with a small delay voltage, whereas a high delay voltage is needed to maintain the distant and local stations at approximate equality of volume. In a sensitive receiver, the reduction of fading is the more important factor.

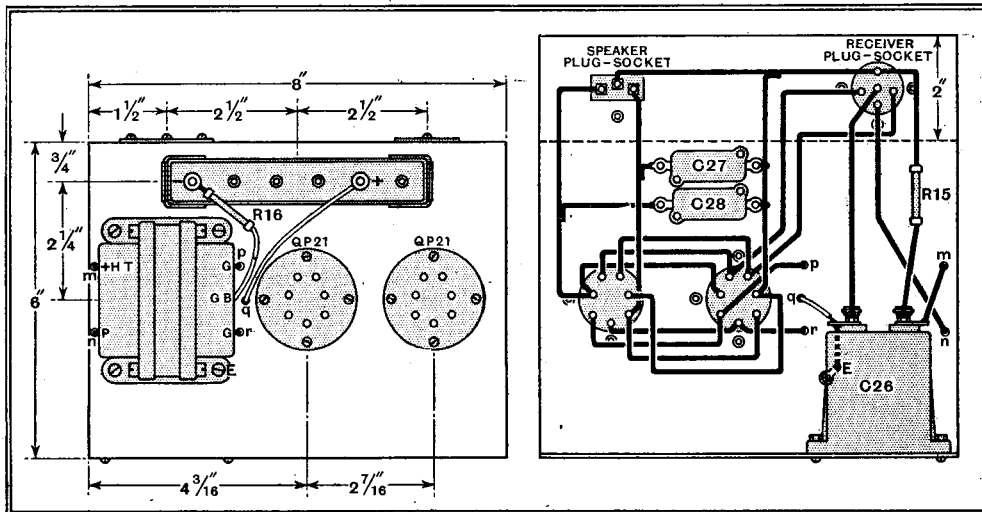

These drawings give complete details of the construction and wiring of the output unit.

Short-wave Broadcasting

DURING October the International Short-Wave Club is holding a reception contest, in connection with which several of the better-known short-wave stations are radiating special programmes.

Readers of these notes who have had any intention of entering for the contest have already filled in their entry forms and received full particulars from the secretary of the Club. There must be many, however, who have not the time to take it seriously, but will be able to appreciate the large number of extra transmissions that will be on the short-wave ether during the month.

The following are particulars of special transmissions from some of the lesser-known stations, with dates and times: La Paz, CP7, 19.6 metres, on October 5th, 4-5 p.m.; Bombay, VUB, 31.36 metres, on October 9th, 4-4.30 p.m.; Costa Rica, TI-RCC, on 45.81 metres, October 19th, 1-3 a.m.; Mexico City, XECR, 40.65 metres, on October 20th, 11 p.m.-midnight.

Lobito, Angola, CR6AA, 41.8 metres, on October 26th, 7.45-8 p.m.; and Lima, Peru, OAX4G, 48.22 metres, on October 31st, midnight-4.30 a.m.

In addition to these, of course, most of the better-known North and South American stations, as well as Nairobi, Sydney and the Europeans, will also be radiating special test programmes.

The Bright Spot—19-metre Band

In spite of the fact that the fade-out time on the shorter waves is becoming earlier day by day, the 19-metre band still seems to be the brightest spot in the short-wave spectrum. It is a great pity that this band is not used by a more varied collection of stations, although the addition of the Bolivian station CP7 (as listed above) on 19.6 metres makes it more interesting.

The four Americans using the 19-metre band are always exceptionally good, and one imagines that if an Indian and a South

African station were to transfer their attentions from 49 or 31 metres, we should have no difficulty at all in logging them regularly.

At the next international convention the whole question of occupancy of short-wave bands is to be brought up. It has even been suggested that short-wave broadcast stations will have to be lined up by something similar to the Lucerne Plan.

"Occupancy checks" on the amateur bands have been made for many months, and have provided much valuable information. Similar checks on the strips of 100-kc, or so on either side of the amateur bands are also being made, so that a claim may be made for the widening of amateur bands if the amount of use made of the adjacent territory appears to be small.

Surely something similar must be done with the short-wave broadcast. There is not one of the official bands which has not a certain amount of commercial interference. Just as certainly there is not a commercial band which does not find several "stray" broadcasting stations within its territories.

If the official broadcast bands can be widened substantially, then there will be no need for this spreading out of stations. Possibly 15-kc. separation would become practical politics. Obviously, however, co-operation between stations is going to be very much more difficult than was the case in Europe where medium-wave broadcasting was concerned.

Taking the present arrangement of the 19-metre band as an example of bad planning, we have three stations listed on 15,250 kc.; one on 15,220; one on 15,210; one on 15,200, and then a gap of 70 kc. with no station. The 31-metre band is even worse, with five stations on 9,590, two on 9,580 and three on 9,570.

The one thing that saves us from real chaos is the fact that these stations are never heard all at the same time, although they often work in pairs.

MEGACYCLE.

Speaker for the 1936 Battery Monodial Super

A LOUD speaker has been received from the Whiteley Electrical Radio Co., Ltd., of Victoria Street, Mansfield, Notts, for the 1936 Battery Monodial Super. It is fitted with a multi-ratio transformer giving impedances from 3,250 ohms to 70,000 ohms and 1 ohm to 22 ohms, so that it can be matched to any output stage and is particularly convenient for use as an extension speaker. Provision is made for use with either single or push-pull output stages. Two switches on the frame permit the ratios to be changed in a moment. For use with the 1936 Monodial Battery Super, the lower switch should be set at HR and the upper at E.

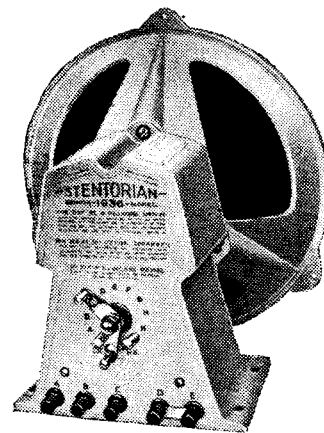

The W.B. P.M. speaker type 36S.

The speaker is well made and can confidently be recommended for use with this set. It is the type 36S and is priced 42s.

H.M.V. Model 360

ALTHOUGH not so sensitive or selective as the superheterodynes in the H.M.V. range, this new receiver will undoubtedly satisfy the demands of the majority of listeners for good reception of the local stations, together with a reasonable selection of foreign programmes. It is of the HF-detector-LF type with a pentode output stage to the moving-coil loud speaker, and is fitted with an input volume control in addition to reaction.

The horizontal cabinet is of high quality, and the loud speaker fret is balanced by a large translucent tuning scale carrying over 200 station names, and illuminated by a large spot of light traversed by a fine black line.

The set is suitable for 200-250-volt, 50-100-cycle mains, and the price is 9 guineas.

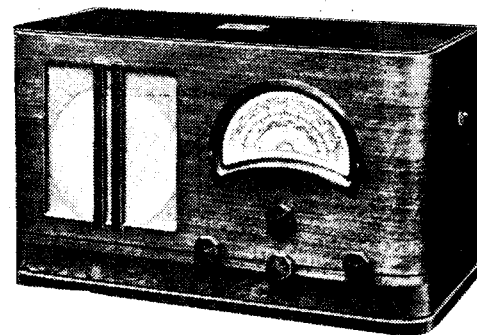

The new H.M.V. Model 360 "Popular 4-valve" receiver.

New Time Base Circuit

An Economical Linear Sweep System

By **DESMOND MacCARTHY**

A LINEAR time base is essential for most applications of the cathode-ray tube, and two are necessary for television reception. Hitherto it has been customary to use equipment embodying either three hard valves or one hard valve and one gas-filled triode. If a push-pull output be required an extra valve is necessary. The hard valve time base has two disadvantages—the number of valves and the length of the return stroke. The gas-filled triode type, however, while having a very rapid return stroke, is apt to be erratic at high frequencies. It is clear, therefore, that an arrangement which employs only two hard valves and which gives a push-pull output offers considerable advantages over the usual system. Push-pull output is, of course, particularly advantageous in television reception, for it permits the avoidance of trapezium distortion.

The system is shown in the illustration, where V_1 is the discharging valve and V_2 the constant current charging device. The condensers C_1 and C_2 are charged at constant current through the screen-grid valve V_2 ;

anode current until the condensers C_1 and C_2 are discharged. The grid then returns to its original potential and thus stops any further flow of current until the condensers charge again.

By means of a potentiometer the voltage on the grid of V_1 may be varied; the voltage at which the condensers discharge can thus be controlled, and so complete control of the amplitude of the saw tooth voltage is obtained. By varying the voltage on the grid of V_2 by another potentiometer the charging current may be varied;

receivers were found to be the most suitable.

The actual coils used were litz-wound and resonated at about 1,400 kc/s. With these coils a very rapid "fly back" was obtained, and it was found possible to work the time base up to a frequency of 15 kc/s before the fly back became very noticeable. At lower frequencies the fly back was invisible.

Adjusting the Coils

The setting of the coils is best done when the time base is connected to a cathode-

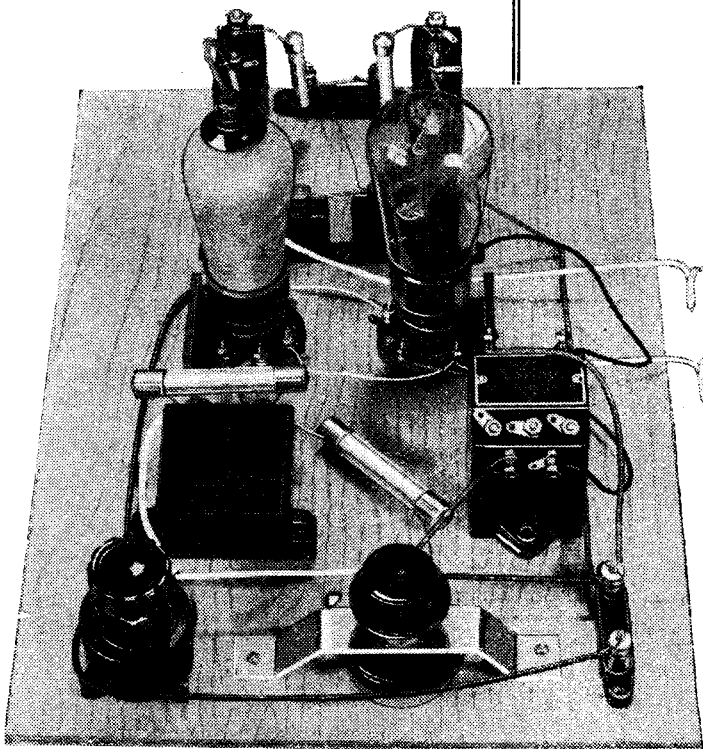
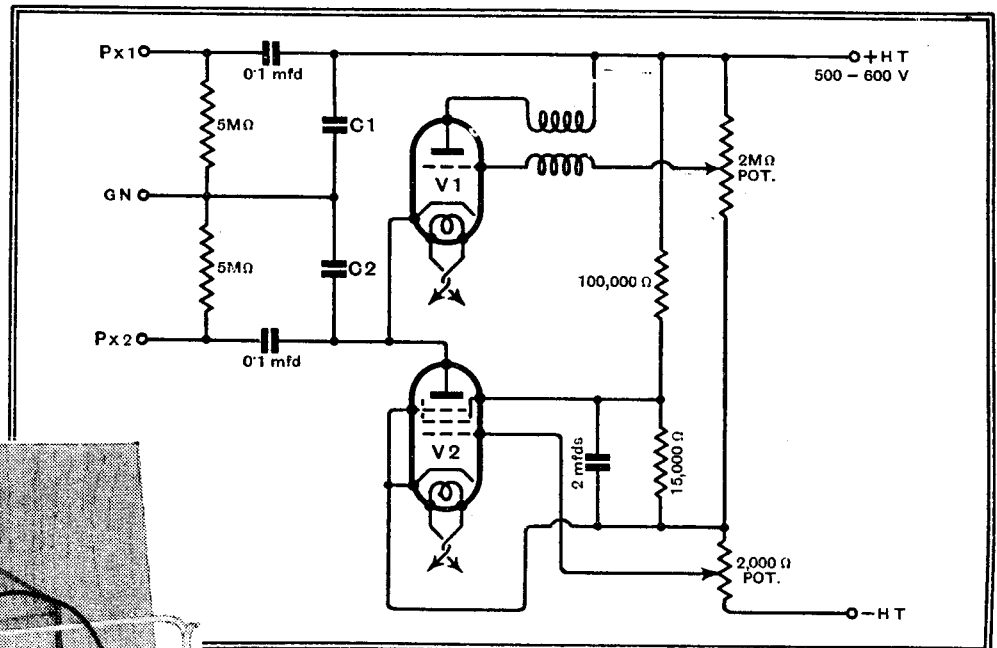

The screen-grid valve in the above circuit performs the function of a saturated diode, and the triode acts to discharge the condensers C_1 and C_2 at the end of the stroke. An experimental time base built for a low-frequency is shown at the left.

ray tube. The coils should be set so as to give maximum amplitude, and once set need not be touched again.

The HT voltage required will depend on the type of cathode-ray tube it is intended for, 500 volts being a suitable figure for a small tube with a first anode voltage not exceeding 1,500 volts. Over 800 volts has been used on this time base with ordinary indirectly heated valves, the current drain being very small.

It is, however, very important that each time base should have its own exclusive HT supply as any other connections to it are liable to upset the push-pull working.

The values of the condensers C_1 and C_2 will depend on the frequency range required. For frequencies in the neighbourhood of 50 c/s the capacities should be about 0.5 μ F. each, and for frequencies near 5,000 c/s approximately 0.0005 μ F. each.

V_2 should be an ordinary HF pentode or SG valve. The variable- μ type is, however, unsuitable. The discharging valve V_1 may be an ordinary indirectly heated triode, such as an MH4.

the voltage on the cathode of V_1 gradually becomes more negative, until it reaches that of the grid. Current then commences to flow through the primary of the transformer in the anode of V_1 . This current causes a voltage to be induced in the secondary, which is connected to the grid in such a way that it makes the grid more positive, thus causing a further increase in

LF transformer was used for the coils in the circuit of V_1 ; it was found to be quite satisfactory for low frequencies, but due to the high primary inductance the rate of discharge of the condensers was too slow for higher frequencies. Various transformers and coils were tried, and eventually miniature basket coils similar to those used in the older broadcast

this potentiometer thus controls the frequency of the saw-tooth wave.

In the original time base an ordinary

The Development of

Part II.—The War Period

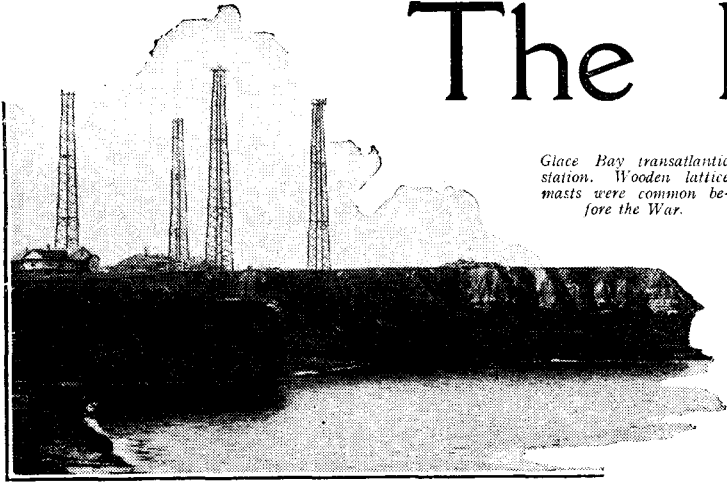

Glace Bay transatlantic station. Wooden lattice masts were common before the War.

THE first article summarised aerial developments in all countries up to August, 1914. The author now describes the intensive research which followed the outbreak of the War and the changes brought about by the introduction of the three-electrode valve. Frame aerials became possible and the first direction-finding stations were erected on land.

IN pre-War days the absence of any kind of amplification at high frequency made a fair-sized external aerial necessary for the reception of anything but very strong signals. As all communication was by morse the number of privately owned receiving stations was very small, and as the aerial had to be visible the possibilities of illicit stations were very limited. Illicit receiving stations were possible, but transmitting stations, except of the smallest range, were not feasible.

Then Came the Valve

The pressure of necessity exerted by the War caused extremely rapid development of wireless technique, the greatest being the swift introduction and improvement of the three-electrode valve. Amplifiers having an enormous gain were constructed quite early in the War, but were very difficult to handle. The indirect effect of the introduction of valves was that they rendered the reception of continuous wave signals by the beat method quite simple, and the use of continuous wave transmission began to increase.

No very great change in the design of aerials for high-power stations was introduced, but dimensions were increased, especially height. Towards the end of the War period masts, towers, or whatever we please to call them, were erected to a height of 800 feet.

The amplification made available by the three-electrode valve made the use of small frame aerials for receiving a possibility, and hence it became possible to

apply the principles of direction finding as it is now understood in practical working.

The first direction finding stations were erected on land. In this country the Bellini Tosi system was almost exclusively used, and very large open frames sup-

ported on small masts were employed. Wooden box masts 120 feet high were most commonly used. A very complete and elaborate system of these stations was created, and there is no doubt that the work done by them had a great effect on the conduct of the War.

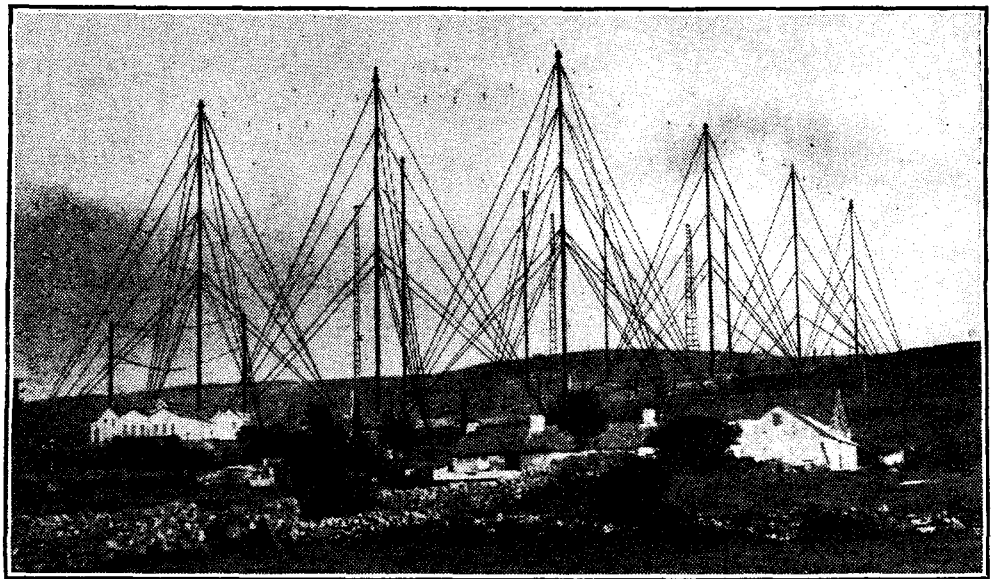

Carnarvon station as it appeared during the War period, when increasingly high masts came into use.

ported on small masts were employed. Wooden box masts 120 feet high were most commonly used. A very complete and elaborate system of these stations was created, and there is no doubt that the work done by them had a great effect on the conduct of the War.

A series of directional transmitting

horizontal aerials was erected round a central mast and the transmitting circuits were connected to them in turn by a revolving commutator. A long dash was made with all the aerials connected, so as to give all-round transmission, and the commutator then worked slowly round the circle, transmission tak-

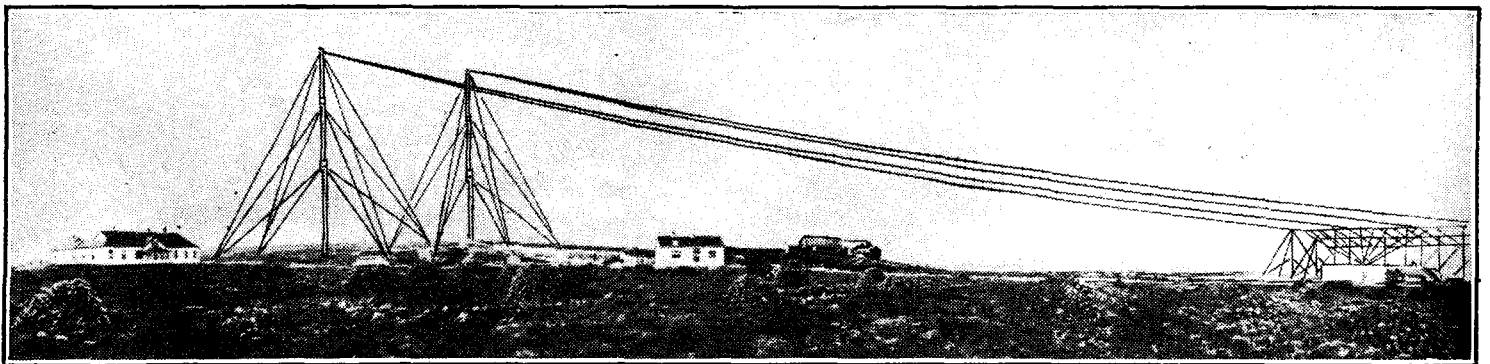

Towards the end of the War aerials increased in length as well as height. A view of Clifden, Ireland.

the Wireless Aerial

By COMMANDER J. A. SLEE,
R.N. (Ret.), C.B.E.

ing place on one aerial at a time. As with most other directional systems the zero was sharply defined, and the time taken for the line of zero transmission to work from the North-South direction (where it started) to the observer gave the number of degrees through which the zero had rotated, and so the bearing from the transmitting station could be obtained.

Aerials in the Trenches

Accurate direction finding at the receiving station in ships and aircraft was not developed till after the War.

The difficulties of maintaining communication in the front line zone by wire, due to the very heavy artillery fire which was used, caused a great demand for very small and easily portable wireless sets for work in the front line trenches. Anything remotely resembling the usual elevated aerial was impossible, as it immediately attracted heavy shell fire. Small frame aerials were used, or aerials disguised as part of the wire entanglement, and innumerable and nameless devices of all sorts were improvised to meet the special requirements.

The early principles of inductive and conductive communication through the soil were also revived, and brought to a high degree of efficiency, but these contrivances cannot be considered as development of the wireless aerial.

Aircraft that carried wireless made use of trailing aerials for transmission, as the power then available with small transmitting valves was not enough to ensure the necessary communication with fixed aerials.

In ships, aerial construction remained unaltered, except that in men-of-war working as part of large fleets an elaborate wireless organisation demanding multiple reception had enforced the use of several independent aerials. The elaborate structures described in last week's article had to be abandoned and smaller and simpler aerials were introduced.

In short, the aerial itself was the only part of wireless equipment which was not developed to an enormous extent during the war period.

All the aerials in use up to this period were of the quarter-wavelength type. At the large fixed stations aerials were designed so that their natural frequency should approach that of the wave to be

transmitted, only a few turns of tuning inductance being required inside the station. The actual length of the aerials did not approach to a quarter of the wave to be transmitted, and the effective height was nothing like it.

The earthing systems had not been fully elaborated, and the total resistance of these aerials was high in comparison with their radiation resistance, so much so that it is doubtful if the efficiency of any of them exceeded 15 per cent.

In the case of small stations the position was much worse, and in ships worse still. The wavelength to be used varied over very wide limits according to the part to be taken by the station in the wireless organisation. If the station happened to be using the higher frequencies an efficiency of, say, ten per cent. may have

one per cent. The construction of tuning coils suitable for heavy currents having a large inductance and low high frequency

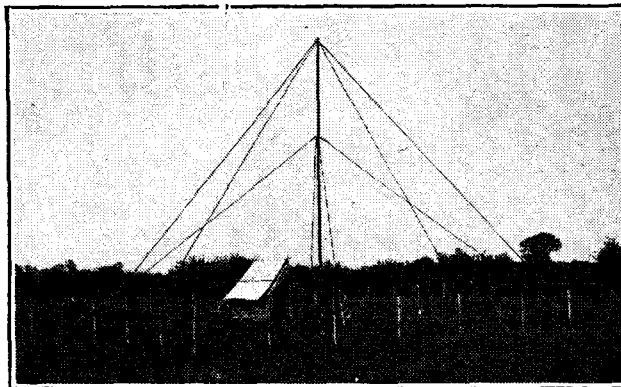

One of the earliest DF aerials—large open frames supported on a small mast.

resistance was not then perfectly understood, and generally speaking the coils in use were much too small in overall dimensions, especially those used in the small stations and in ships.

(To be continued.)

THE RADIO INDUSTRY

IN view of the present interest in midget or truly portable receivers, it is interesting to learn that the Exide Company produce no fewer than nineteen different types of Drydex midget HT batteries with voltages varying from 18 to 75 volts.

Although the standard Belling and Lee "Set Lead Suppressor," rated to carry 0.5 amp., is suitable for the great majority of receivers, a unit with a somewhat higher rating is necessary for certain large radiogramophones. Accordingly, a new model, No. 1256, rated at 1 amp., has been produced at the price of 19s. 6d. Belling and Lee express the hope that all users of their appliances will take advantage of their Information Service in cases of difficulty.

For use in conjunction with certain new valves now appearing on the market, a special Dubilier condenser has been introduced. This is of the oil-immersed type, with a capacity of 10 mfd. and a working voltage rating of 750 volts. The price is 17s.

Postlethwaite Bros., of Church Hill, Kinver, Stourbridge, Worcs, have just issued leaflets dealing with a number of new products. These include tunable whistle suppressors, fixed cut-off filters, various HF chokes and wave traps, etc.

The new season's catalogue of Rola loud speakers is now available from the British Rola Co., Ltd., Minerva Road, Park Royal, London, N.W.10.

Acheson colloidal graphite (Aquadag) is now being used, in the form of a film deposited on the glass bulb, as a shield against charging and extraneous high-frequency disturbances in the manufacture of Plictron and Thyatron valves. Technical information on this and other uses of Aquadag is obtainable from E. G. Acheson, Ltd., Thames House, Millbank, London, S.W.1.

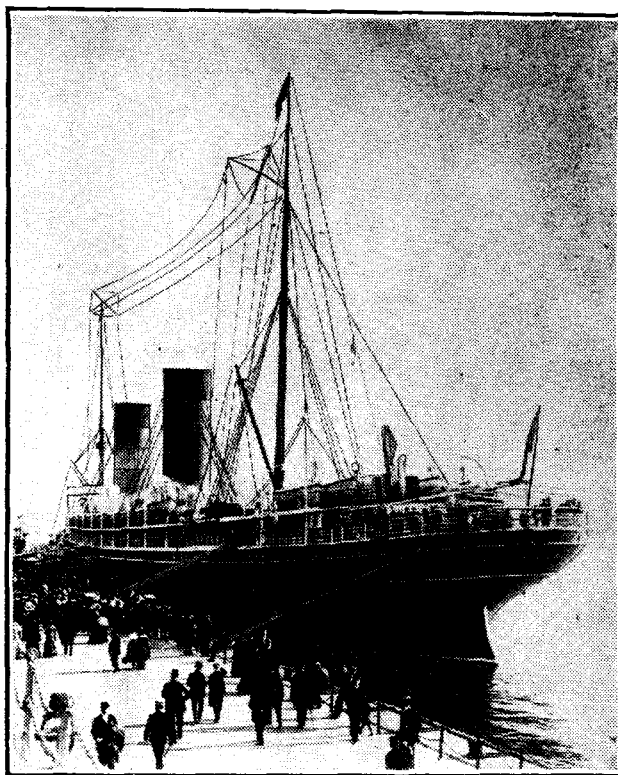

Ships' aerials became simpler in design. Compare this installation on the "Lucania" about 1912 with the elaborate arrangement on the "Carlo Alberto" illustrated in our last issue.

been possible, but when the organisation demanded the use of longer waves and the aerials had to be loaded with large values of inductance its total resistance soared up while its radiation resistance fell, and the efficiency of transformation of electrical energy in the primary to radiated energy in the ether cannot have been more than

Current Topics

Events of the Week in Brief Review

Next . . . Cairo

ALL roads will lead to Cairo on February 1st, 1938, the date selected by the Egyptian Government for the opening of the international conference on telegraphy, telephony and wireless matters which, by the decision of the Madrid Conference of 1932, is to be held at Cairo.

Slot Machine Radio

PENNY-IN-THE-SLOT radio and gramophones may be introduced in restaurants and public houses within the next week or two by Radiogram and Television Ltd. One penny in the slot will give the listener two gramophone records or six minutes of radio with a choice of stations shown on a notched dial.

Marconi Honoured

MARCHESE MARCONI during his visit to Brazil has been decorated by the Foreign Minister with the Order of the Cross of the South. The Rector of Rio University conferred on him the appointment of Professor Honoris Causa.

The Marchese has also been appointed to the newly founded Chair of Electro-Magnetic Waves at Rome University.

Paderewski Broadcast Off

MILLIONS of American listeners have been disappointed by the news that Paderewski, the great pianist, who was to have broadcast a recital from Switzerland on October 12th, will be unable to fulfil the engagement owing to a slight illness. Paderewski is named with Fritz Kreisler and Rachmaninoff as one of the three first-rank artists who have never yet broadcast in the United States.

Paderewski once broadcast from Savoy Hill, but afterwards described the experience as so "horrible" that he vowed never to face the microphone again.

Simultaneous Picture Transmission

THE radio transmission of a picture from San Francisco to New York and London simultaneously was successfully carried out by the Radio Corporation of America after Sir Malcolm Campbell's speed trials at Utah. The signals were sent via two separate amplifiers, one operating a recorder in New York, and another actuating a radio transmitter at Rocky

Point, Long Island, connected by beam with London.

In addition to the saving of time, London benefited by obtaining a picture as clear as if received in New York. When a picture is sent twice a "double screening" effect mars its clarity.

Monitoring World's Programmes

OUR Paris correspondent sends interesting details of the new French Listening Centre, the object of which is to tune in all the most important broadcasts throughout the world and to prepare translations for submission to the Minister of Posts and Telegraphs.

The equipment is contained in three sections of the Vicétre

can also be recorded on steel tape. The Bureau is under the supervision of M. Pellenc, Director of Broadcasting.

Unusual Accident

M. ANDRE HUGUES, announcer at Radio Algiers, is the first victim of the gramophone pick-up. During a recent broadcast he pricked himself with a gramophone needle and in consequence has had to have his right thumb amputated.

C.B.S. Medal

ADMIRAL BYRD has been presented with the Columbia Broadcasting System's Distinguished Service Medal for 1935 "for contributions to radio." The five previous recipients of the honour have been

The Patents Show

WIRELESS enthusiasts will find a number of interesting devices at the Eleventh International Exhibition of Inventions now being held in the Central Hall, Westminster, from 11 a.m. to 10 p.m. daily. The Exhibition remains open till October 12th.

Freedom of Speech

THE American Civil Liberties Union is apparently perturbed by the real or imaginary censorship imposed on speeches broadcast from American stations. The Union contends that the operators of the 500-kW. Cincinnati station WLW have issued secret orders that no reference to strikes is to be made in any news bulletin. This is denied by the officials of WLW.

The Federal Communication Commission, in replying to a complaint from the Union, states that it has no authority to act in such cases.

The Broadcaster Pays

A REMARKABLE decision has been arrived at by the Tangiers magistrates. A broadcast listener was enjoying a radio drama with his faithful bulldog beside him. Suddenly, in the action of the play, came the barking of a dog, whereupon the listening animal flew at the set and smashed it to pieces. When the owner of the receiver took action against the broadcasting station to recover the value of the demolished receiver the Court decided in his favour on the grounds that "a broadcasting station has no legal right to cause disturbance in a home and incite the fury of domestic animals."

"Chronicle" Wireless Annual

COINCIDING with the Wireless Exhibition, the *Manchester Evening Chronicle* issues the "Chronicle Wireless Annual," now in its thirteenth year. The 134 pages are packed with useful information, from "Little Things that Count" (practical hints by "Radidea" of the *Manchester Evening Chronicle*) to a description of the Marconi, Baird, and Cossor television systems. Designs for home receivers are included, together with descriptions of well-known commercial models.

The Annual, price 1s., is published by Allied Newspapers, Ltd., Withy Grove, Manchester, 4.



A WIRELESS SET was included in the gifts presented at the altar of St. Peter's Church, Plough Road, Battersea, on Sunday last during the Harvest Festival Service. The gifts were afterwards sent to various charitable institutions.

Fort, to the south of Paris. In the first section twenty receivers, of which ten operate on the short waves, permit of a constant watch on the world's wireless broadcasts throughout the twenty-four hours. A second section is reserved for listening to musical programmes, and the third is devoted to reception in the interests of national defence.

Receivers are connected by a special cable to the Post Office headquarters in the centre of the city where twenty multi-lingual women stenographers can take down broadcast speeches and, within twenty-five minutes, pass out a typed report. Broadcasts

Sir John Reith, Colonel Charles A. Lindbergh, Amelia Earhart, Leopold Stokowski and Nino Martini.

The Farmer's Home

OUR associated weekly journal, *The Farmer and Stock Breeder*, now includes under the title of "The Farmer's Home," a 16-page supplement in photogravure containing four full pages of beautiful reproductions of farming pictures, together with wireless, cookery, fiction, fashions, and many other interesting features. The price remains at twopence per copy complete with supplement.

Television Transmissions

DETAILS OF THE BAIRD AND MARCONI-E.M.I. SYSTEMS

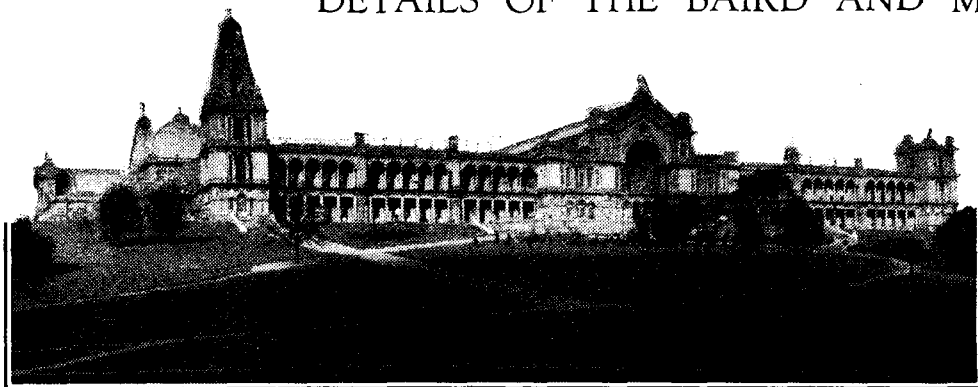

TECHNICAL details of the nature of the high-definition television transmissions which will be radiated from the Alexandra Palace have long been awaited. At the request of the B.B.C., the Baird and the Marconi-E.M.I. companies, who are responsible for the development of the apparatus, have now issued statements defining the nature of the transmissions. These official statements are reproduced in full in these pages, and a summary of the chief points of importance contained in them appears in this article.

THE eagerly awaited details of the transmitting arrangements which will be employed on the opening of the Alexandra Palace ultra-short-wave station have at last appeared and the full statements issued by the Baird and Marconi-E.M.I. companies are printed at the end of this article. The details given are chiefly about the form of the synchronising signals and are essential to the design of a receiver. Their practical interpretation in receiver design is, of course, a matter which is left to the designers of the equipment, and there is no doubt that many different solutions to the problems involved will be found.

In spite of the differences between the Baird and Marconi-E.M.I. transmissions many points of similarity are to be found. Owing to the irregular nature of the modulation it is hardly possible to picture the transmission in the familiar way as a carrier having a constant average amplitude but an absolute amplitude which varies from moment to moment about the mean. With television it is much more convenient to work in terms of the maximum amplitude during 100 per cent. modulation; this is an amplitude just double that of an unmodulated carrier.

The Picture Signal

The picture itself is conveyed by changes in the carrier amplitude over a range of 40 per cent. to 100 per cent. in the case of the Baird transmissions, and over a range of 30 per cent. to 100 per cent. in the case of those transmitted by the Marconi-E.M.I. system. Thus Baird uses 60 per cent. of the total available range of amplitude for conveying the picture, and Marconi-E.M.I. 70 per cent. The remaining portion of the carrier amplitude range is not wasted but used for synchronising. In each case a rise in carrier amplitude corresponds to a brightening of the picture, and the gear should be so adjusted that black occurs for a 40 per cent. amplitude for Baird transmissions and 30 per cent. for Marconi-E.M.I. A fall in the carrier below these values can

then cause no change in the picture, for the light-spot is already extinguished. The 40 and 30 per cent. amplitudes can be thought of as a sort of dividing line between the picture impulses and the synchronising, for at suitable intervals the carrier amplitude falls from this line to zero to give synchronising pulses.

Now in the Baird system there are 25 pictures a second and 240 lines to a picture, so that there are 25 synchronising impulses a second for the frames and 6,000 for the lines. The line synchronising pulses occur at the start of each line and each occupies 8 per cent. of the total time of traverse for one line. In addition, a further 2 per cent. is occupied by a black edging to the picture. A total of 10 per cent. of the line time is thus occupied by the synchronising pulse and the edging, and the receiving gear should be so arranged that the return stroke of the time-base occurs within the 2 per cent. devoted to the border in order that it may be invisible.

A similar procedure is adopted in the case of the frame pulses. Here the synchronising pulse occupies 12 lines and the edging 8 lines, so that out of the total of

240 lines forming a complete frame, only 220 appear in the actual picture.

Now in the Marconi-E.M.I. system the arrangements are rather more complex because in an effort to reduce flicker, interlaced scanning is used. There are actually 50 frames a second and 405 lines, but this statement must be interpreted differently from usual, for there are neither 50 complete pictures a second nor 405 lines to each frame. Actually, there are 50 half-pictures a second, each containing 202.5 lines. In effect, in each half-picture, each line is spaced from its neighbours by twice the normal amount so that there is an appreciable gap between the lines. The next half-picture scans the bits missed by the first and fits into the gaps left by the first. Thus the second picture is similar to the first but is staggered slightly so that its lines fall into the gaps between the lines of the first.

As in the Baird system, a portion of each line is used for the synchronising impulses, and 15 per cent. of the total time occupied by one line is allotted to this, 10 per cent. of the line time being devoted to the actual synchronising impulse and 5 per cent. to the provision of a black edge to the picture during which the return stroke of the cathode-ray gear can take place. Thus a total of 85 per cent. of the line is used to provide the picture.

Certain lines are also devoted to the synchronising, and between frames there is an interval of 10 lines, so that the number of lines in each frame actually effective in producing the picture is 192.5. The frame synchronising consists of two pulses for each line, each pulse being equal in length to 0.4 line and separated by an interval of 0.2 line. At least 3 lines (6 pulses) will be transmitted in this way, but up to 6 lines (12 pulses) may be used, the remaining 7 to 4 lines being black with the normal line synchronising signal at the commencement of each.

The precise position of the frame syn-

	Baird.	Marconi-E.M.I.
Number of frames per picture	1	2
per second	25	50
Number of lines per picture	240	405
per frame	240	202.5
per second	6,000	10,125
Picture ratio	4 : 3	5 : 4
Number of lines in each frame for		
synchronising	12	3-6
black edging	8	7-4
picture	220	192.5
Proportion of each line devoted to		
synchronising	8%	10%
black edging	2%	5%
picture	90%	85%
whole line	166.666	98.765
Total time in micro-seconds of		
synchronising	13.333	9.876
black edging	3.333	4.983
picture portion	150.0	83.95
whole frame	40	20
Total time in milli-seconds of		
synchronising	2	0.2963-
black edging	—	-0.5926
picture	1.333	0.6914-
picture portion	36.666	-0.3051
whole frame	—	19.0123
Ratio of black edging to frame	27.5 : 1	27.5 : 1-
picture, i.e., stroke to fly-back of time-base line	45 : 1	-48.1 : 1
Range of modulation depth for black to white in picture	40-100%	30-100%
Tolerance during programme	± 2.5%	± 3%
Additional day to day tolerance	—	± 3%
Range of modulation depth for synchronising	0-40%	0-30%

Television Transmissions—

chronising impulses depends upon the picture being transmitted. In the case of the first frame, the first synchronising pulse occurs exactly one-half line after the commencement of a line, so that whereas an ordinary line is made up of 10 per cent. line pulse, 5 per cent. black and 85 per cent. picture, the first synchronising line of the first (and all odd numbered) pictures is made up of 10 per cent. line pulse, 5 per cent. black, 35 per cent. picture, 40 per cent. frame pulse, 10 per cent. black. The next line, however, starts off with 40 per cent. frame pulse, 10 per cent. black, 40 per cent. frame pulse, 10 per cent. black, and so on.

The second picture (and all even numbered pictures) is different, for the first line devoted to the framing synchronisa-

tion does nothing else. The first 40 per cent. line pulse occurs at the start of this line and is followed by a 10 per cent. black, another 40 per cent. pulse, and concludes with 10 per cent. black just as do the other lines in all the pictures, whether even or odd.

In the case of receiving equipment designed to operate from both types of transmission, one of the chief requirements is obviously that the time bases shall respond correctly to the different synchronising signals employed. Means must also be provided for changing the frequencies generated. For Baird reception, one time base must give 25 strokes a second and the other 6,000, whereas for Marconi-E.M.I. transmissions one time base must give 50 strokes and the other 10,125. Moreover, the relative outputs of the two time bases must be

altered, for the picture ratio of Baird transmissions is 4:3, whereas that of the Marconi-E.M.I. is 5:4. The Marconi-E.M.I. transmissions involve higher modulation frequencies than the Baird, and the highest frequencies involved are about 2 mc/s instead of only 1 mc/s.

The statements issued provide the essential data upon which the design of receiving equipment must be based, and are consequently invaluable to all designers and experimenters in this field. It should be emphasised, however, that the information is only basic and an enormous amount of work is waiting to be done in the development of simple and reliable gear which can hardly be started until the commencement of regular television transmissions. It is to be hoped, therefore, that these will not be much longer delayed.

The Baird System

Details of the Signal Radiated

THE drawing, Figure 1, gives complete details of the waveform for picture modulation and synchronising impulses. From this it will be seen that, using the arbitrary aerial current units of zero to 100, the total modulation for synchronising (black) extends between the tolerance limits of zero to 5 and 37.5 to 42.5, while the picture modulation (black to white) extends between the tolerance limits of 37.5 to 42.5 and 100.

It will be noted that the high-frequency synchronising impulse is rectangular in shape and is maintained for 8 per cent. of the total time taken in tracing the line, and occurs between the line traversals. The low-frequency synchronising impulse, which is also rectangular in shape, is maintained during the time that

12 lines are traced, and occurs between the frame traversals. These traversals, as seen by an observer looking at the received image from the front, scan from left to right (line) and from top to bottom (frame).

The drawing also shows that, in addition to the above 8 per cent. of the line traversal time occupied by the high-frequency synchronising impulse, a further 2 per cent. is masked off to form a black edging. Similarly, an additional 8 lines are masked off in the case of the low-frequency synchronising impulse for the same purpose.

The total number of lines in the complete picture is 240, scanned sequentially and horizontally at 25 picture traversals per second and 25 complete frames per second. The line frequency is thus 6,000 impulses per second and the frame frequency 25 impulses per second. The dimensions of the observed picture have the ratio of 4 horizontal to 3 vertical.

Amplitude modulation is employed, which results in light intensity modulation in the observed picture, the transmitter carrier increas-

ing towards the white. The line synchronising signals and the frame synchronising signals are in the sense opposite to increasing picture modulation. The maximum frequency band involved in the transmission is 2 megacycles, and the average component of light in the picture is transmitted, a black in the picture being transmitted as black and a white transmitted as white, in accordance with the modulation percentages referred to above.

Marconi-E.M.I. System

Specification of Radiated Wave-form

THE Marconi-E.M.I. television system transmits 25 complete pictures per second, each of 405 total lines. These lines are interlaced so that the frame and flicker frequency is 50 per second. The transmitter will radiate signals with sidebands extending to about 2 megacycles either side of the carrier frequency. Good pictures can be received utilising only a fraction of the radiated band, but, naturally, the quality of the received picture will depend upon the degree to which the receiver makes use of the transmitted band width. The transmitted wave-form is shown in Figure 2.

(1) Line Frequency.

10,125 lines per second, scanned from left to right when looking at the received picture.

(2) Frame Frequency.

50 frames per second, scanned from top to bottom of the received picture.

(3) Type of Scanning.

The scanning is interlaced. Two frames, each of 202.5 lines, are interlaced to give a total of 405 lines with a complete picture speed of 25 per second. The line component and the frame component of scanning are regularly recurrent, the interlace being derived from the fractional relationship between line and frame frequencies. An explanation of the method of interlacing is given at the end of this specification.

(4) Interval Between Lines.

There will be intervals between the vision signals of successive lines, which intervals provide time for the transmission of a line synchronising signal and also provide time for the return of the cathode ray beam to the beginning of the next line. The minimum interval between the vision signal of successive lines will be 15 per cent. of the total line period (1/10125 sec.), the first 10 per cent. of this interval between lines being occupied by the line synchronising signal and the remaining 5 per cent. by a signal corresponding to "black" in intensity. The remaining 85 per cent. of the

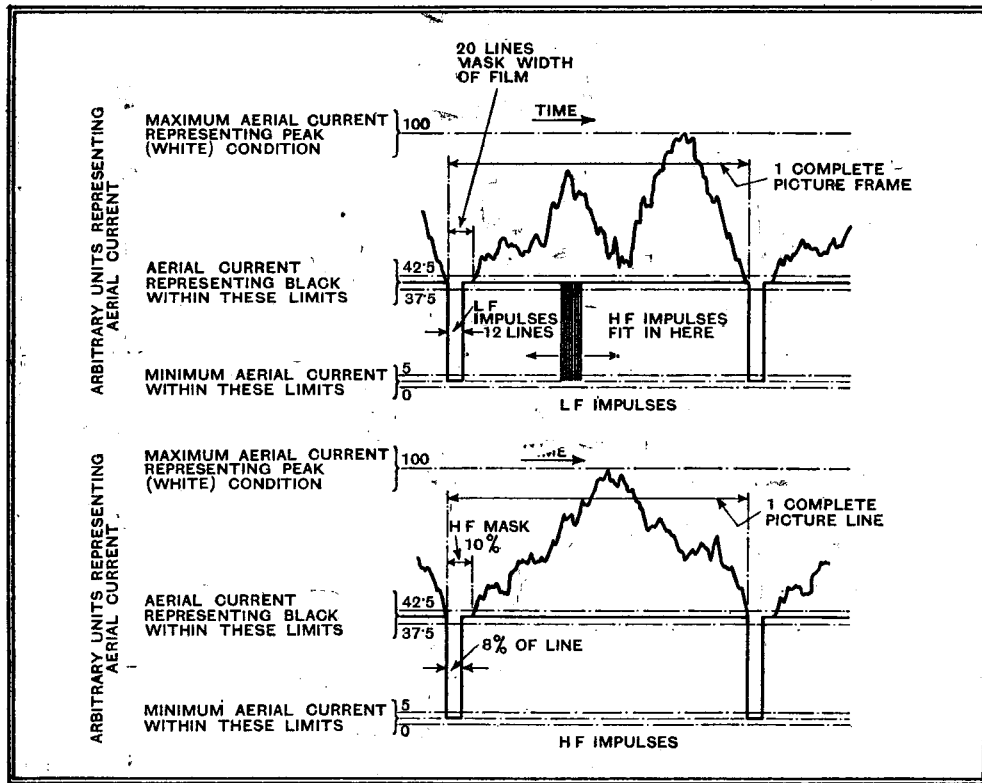

Fig. 1.—The picture modulation and synchronising impulses of the Baird transmissions. The drawings are made from tracings taken off the vision radio transmitter monitoring oscillograph.

Television Transmissions—

total line period is available for transmitting vision signals.

(5) Interval Between Frames.

There will be intervals between the vision signals of successive frames. The minimum interval between frames will be 10 lines, leaving a maximum of 192.5 active lines per frame, or 385 active lines per complete picture.

(6) Picture Ratio.

The picture ratio will be 5 : 4, that is to say, the distance scanned during the active 85 per cent. of the total line period will be 5/4 times the distance scanned during the 192.5 active lines of the frame.

(7) DC Modulation.

The picture brightness component (or the DC modulation component) is transmitted as an amplitude modulation so that a definite carrier value is associated with a definite brightness. This has been called "DC working," and results in there being no fixed value

would have been a line signal. At the end of odd frames the first frame pulse starts half a line after the preceding line signal. At least six frame signals will be transmitted at the end of each frame, but the number may be increased to any number up to 12 pulses (6 lines). During the remainder of the intervals between frames normal line synchronising signals will be transmitted with black (30 per cent. peak) signals during the remaining nine-tenths of the line.

It will be noted that throughout the interval between frames (as during the whole transmission) the carrier falls from 30 per cent. to zero regularly at line frequency and in phase with the beginning of the normal line synchronising pulses.

(12) Variations in Transmitted Wave-form.

The 15 per cent. interval between vision signals of successive lines, and the 10 lines interval between successive frames are minimum intervals used at the transmitter. Dur-

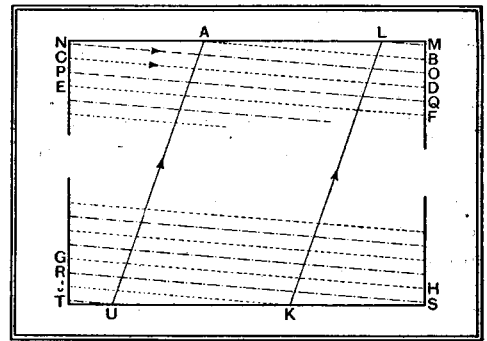
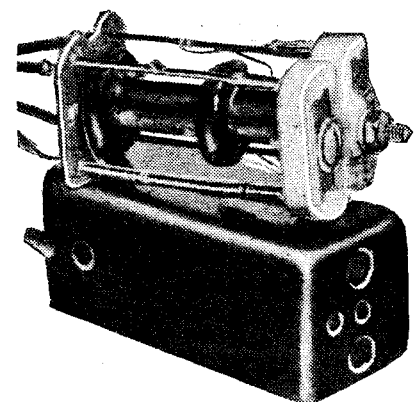

Fig. 3.—This diagram shows the method of interlaced scanning to be used in the Marconi-E.M.I. transmissions.

right motion (line scan) with very quick return (not shown on drawing). The combination of these motions produces the slightly sloping scanning lines. Starting at A, not necessarily at the beginning of a line, the spot completes the line A B, returns to the left and traverses line C D, then E F, and so on down the "dotted" lines on the drawing. At the bottom of the frame the spot travels along line G H and then starts at J and travels to K. At this point the return stroke of the frame motion begins and returns the spot to L at the top of the frame. A complete frame scan has now been made since leaving A, so that 202-1/2 lines have been completed, and the point L is half a line away from A. The downward frame motion now starts again, causing the spot to travel along L M, completing a single line motion J K L M. The spot then returns to the left and traces out line N O, which, due to L being half a line ahead of A, will lie between lines A B and C D. Similarly, the next line P Q will lie half way between C D and E F. The spot now traces down the chain-dotted lines to R S and finally traces out T U, at which latter point the frame return causes the spot to rise again to the top. When the spot reaches the top it will have completed two frames since leaving A, and, as two frames occupy the time of exactly 405 complete lines, the spot will return exactly to A, after which the cycle begins again.

From the foregoing it will be seen that the complete picture is scanned in two frames, but as each frame contains an integer number of lines, plus a half, the two frames will interlace. The system does not require the short return times shown for the line and frame scans, nor need the lines begin in the positions shown. Provided the line and frame traversals are regularly recurrent and have the correct frequency ratio (two frames=odd number of lines), an interlaced picture will be obtained.

American Iron-cored Coils



This photograph, sent to us by Aladdin Radio Industries, of Chicago, shows an IF transformer fitted with a core of the new Polyiron material developed by the Johnston Laboratories.

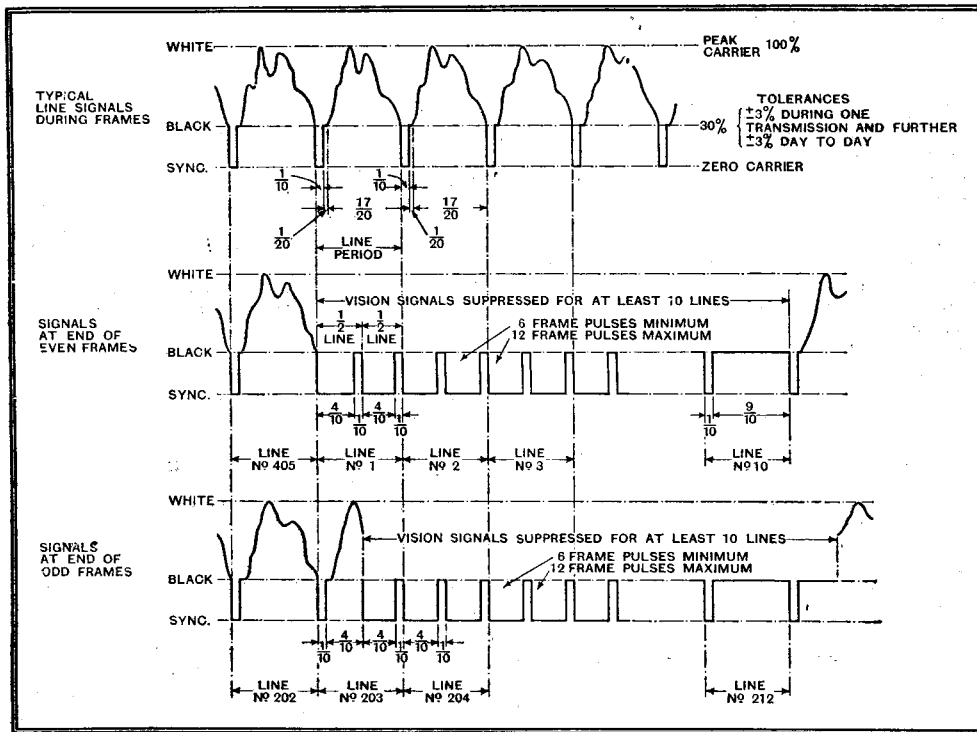

Fig. 2.—The wave-form of the transmissions by the Marconi-E.M.I. system.

of average carrier, since the average carrier varies with picture brightness. The radio frequency transmitter output is specified in what follows as a percentage of the peak output. This percentage is in terms of current (or voltage) and not in terms of power.

(8) Vision Modulation.

The vision modulation is applied in such a direction that an increase in carrier represents an increase in picture brightness. Vision signals occupy values between 30 per cent. and 100 per cent. of peak carrier. The amount by which the transmitted carrier exceeds 30 per cent. represents the brightness of the point being scanned.

(9) Synchronising Modulation.

Signals below 30 per cent. of peak carrier represent synchronising signals. All synchronising signals are rectangular in shape and extend downwards from 30 per cent. peak carrier to effective zero carrier.

(10) Line Synchronising Signals.

The line synchronising signals are of one-tenth of a line duration, and are followed by a minimum of one-twentieth of a line of black (30 per cent. peak) signal.

(11) Frame Synchronising Signals.

The frame synchronising signals comprise a train of two pulses per line, each occupying four-tenths of a line and having one-tenth of a line interval of black (30 per cent. peak) signal between them. At the end of even frames the first frame impulse starts coincident with what

ing the initial development of the transmitter certain transmissions may have longer intervals between lines and between frames, which lengthened intervals correspond to the transmission of a black border round the picture.

The 30 per cent. carrier is the "black level" below which no vision signals exist and above which no synchronising signals extend. The mean black level of any transmission will be 30 per cent. of peak carrier. The black level during any one transmission will not vary by more than 3 per cent. of peak carrier from the mean value of that transmission.

The residual carrier during the transmission of a synchronising pulse will be less than 5 per cent. of the peak carrier.

The line frequency and the frame frequency will be locked to the 50 c/s supply mains, and therefore will be subject to the frequency variations of the mains.

EXPLANATION OF METHOD OF INTERLACING.

The method of interlacing is demonstrated in Figure 3, which represents the top and bottom portions on the scanned area with the distance between the lines very much enlarged. The lines show the track of the scanning spot, which moves under the influence of a regular downward motion (frame scan) with quick return and a regular left to

Contrast Expansion

SOME while ago I was present at an I.E.E. discussion on the design of the H.M.V. 15-valve "High-Fidelity" radiogramophone. Readers may remember that one of the features of this elaborate instrument is "contrast expansion." For the benefit of any who have not their back numbers handy for looking up the particulars, I would explain that it is impracticable to transmit the full range of volume that occurs, say, in an orchestral concert. The loudest *ff* may be as much as ten million times stronger than the softest *pp*. To radiate such a programme faithfully it would be necessary for the modulation of the carrier wave to be effected between these remote limits.

Even a perfect transmitter cannot be modulated more than 100 per cent., so that fixes the upper limit quite definitely. In fact, it is generally undesirable in practice to exceed about 80 per cent. But call it 100. The power is proportional to the square of the percentage modulation; so according to the above assumptions the softest passages of the music modulate the carrier wave only about 0.03 per cent. This would certainly be lost in the more or less unavoidable background of disturbances due to causes both inside and outside the transmitter concerned.

Wasted Power

One has only to consider the power of stations that stand out above interference sufficiently to be of any real programme value. A 100-kilowatt station should be heard clearly above the turmoil. But imagine the consequences if a 0.00001 kilowatt station were substituted! Even apart from the competition of outside noises, it would be very difficult to ensure that amplifier noises and generator hum in the transmitter itself were kept a long way below 0.03 per cent. modulation. Similar principles apply to gramophone recording.

There is another side to it: music which was predominantly *ff* would be intolerable; the average loudness may be assumed to be somewhere about halfway between the extreme limits. So our 100-kilowatt station would be, at average modulation, as effective as a 0.03-kilowatt station working to full capacity. (The two things are not entirely equivalent, but this comparison gives some idea of the waste of transmitter power.)

Of course, it is absurd. The broadcasting people have to contract the range of volume which, instead of being in the ratio of millions to one, is reduced to thousands to one. To put it in its least pleasant terms, they introduce deliberate distortion. The object of contrast expansion is to nullify this distortion and restore the full original range of volume. The

The Difficulty of Deciding For or Against

By "CATHODE RAY"

principle of the method is quite simple; it is just a reversed AVC system applied to the audio amplifier instead of to the radio or IF. Details have been given in *The Wireless World*.

Snag No. 1 is that if the orchestra goes from *pianissimo* to *fortissimo* without warning (as in Haydn's "Surprise" symphony, where the avowed object is to galvanise members of the audience who have fallen asleep) the crest of the outburst has reached the loud speaker before the expander circuits have had time to exercise control, and the force of the attack is thereby weakened. There are methods for holding up the programme for a fraction of a second until the amplifier is ready to cope with it, but they are too complicated for ordinary use. If the expander is properly designed this defect is not generally considered very serious.

Snag No. 2 is that if the volume were expanded to its original proportions it would require kilowatts rather than watts output from the amplifier to handle it. There is no scope for reproducing Queen's Hall conditions in an ordinary living room. Accordingly, only a partial expansion is practically attempted. There is room for divergence of opinion as to how this expansion should be distributed.

Snag No. 3 is more serious. It is perfectly obvious that the final result can correspond to the original only if the expansion is the exact inverse of the contraction, and that this calls for unusual co-operation between transmitting and receiving ends. Unfortunately (for this

tem might compress the range of volume as shown by B. But with manual control each sudden crescendo is anticipated by leading up to it with a gradual reduction in volume—too gradual to attract the notice of the listener—thus allowing for a greater effect at the critical moment. A certain level of original volume, therefore, is not subject to the same definite amount of control at all times.

The resultant of this type of transmitter control and any automatic system of receiver control clearly does not constitute faithful reception. It may be argued that it is even worse than non-expanded reception.

Facsimile or Illusion?

A participant in the I.E.E. discussion put forward the view that it isn't *faithful* reception that is wanted. We have striven so long for the ideal of reproducing at the receiver *exactly* what can be heard in the studio—or elsewhere—that this may sound rank heresy. Yet if broadcasting substantiates its claim to art status it will find itself in the company of this very heresy. What would be thought of a painter, a sculptor, a playwright, a photographer, or a film producer who pursued the ideal of exactly portraying the original? Like a picture or a film, loud speaker reproduction conveys an illusion of something which in itself it is not. There is, therefore, excellent precedent for a school of practice that strives, not for an exact replica of an original, but for the ideal home entertainment.

To achieve this it may be deemed necessary to exaggerate here or to suppress there. The closest parallel in other fields is the intensification and reduction processes in photography, whereby contrast may be made to differ from that in the original. If it be asserted that, in catering for non-expanding receivers by practising a system that baffles the more advanced types, the B.B.C. is a block in the way of progress, the reply is that of the 50,000,000 or so receivers in the world, there are probably not 500 adapted for contrast expansion, and it is not likely that for a questionable æsthetic advantage the gap would be rapidly bridged even if the broadcasters were more accommodating.

That is not to say that contrast expansion is useless. Far from it. Just as a tone control is valuable for getting desired effects, whether or not they are entirely true to life, contrast control is an interest-

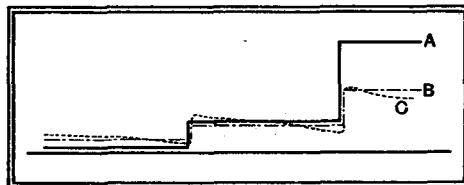

Hypothetical curves of comparative sound intensities without control (a), with automatic control (b), and with manual control (c).

purpose) the method in vogue at the B.B.C. transmitters is to control the output by hand. Not only does this fail to secure the exact proportionality of an automatic device, but in fact the deliberate intention is to produce the best possible effect in ordinary non-expanding receivers by varying the degree of control on an artistic rather than a mechanical basis.

The diagram gives some idea of how this is done. Line A represents the original volume of sound, increasing suddenly at two points. An automatic sys-

Contrast Expansion—

ing extra "effect" that can in any case be switched out if not wanted.

And for gramophone purposes there is rather more argument in favour. Maximum volume is strictly limited by the greatest allowable "waggle" of needle track, and minimum volume by surface noise, otherwise known as scratch. Here we have something that does not apply in radio; a prominent and irreducible background noise. You may say it can be reduced by a scratch filter; but I am assuming "high-fidelity," and when all has then been done scratch is too prominent to go unnoticed if quiet passages were reproduced down to anything like their true volume. Therefore it is considerably beneficial if the volume is reduced by contrast expansion to make the strongly recorded quiet pieces sound really *pp* and at the same time to reduce the scratch.

From a strictly technical standpoint a contraction - expansion system presents a rather more appealing claim. I have already indicated, rather loosely I fear, how the necessity for reproducing light and shade of volume in a transmission leads to the transmitter being effectively of

much less than its rated power. Mr. d'Orsay Bell, in a letter to *The Wireless World*, referred to a proposal to carry the contrast contraction to its ultimate limit by modulating the carrier wave to its maximum extent all the time, thus putting across as much as an ordinary transmitter of many times the power. At the receiver the variations of volume are reintroduced by corresponding expansion. But how? If the level as received is constant, what tells the expansion control when to cut it down, and by how much?

Some variability of modulation must be retained, if only for expander control purposes. Owing to the nature of speech and music modulation it is probable that the ratio of expansion could not be made much larger than the ratio of transmitter modulation, without risking serious trouble (snag No. 1, for example). Still, it does seem as if the transmitter efficiency could be very greatly increased by raising the lower limit of modulation far above even its present controlled level. But it would be a dirty trick to play on the millions of listeners who are not prepared to provide themselves with a more elaborate sort of receiver to suit the system.

and associated apparatus. A plain undrilled metal panel is supplied to which the base-board can be fixed and the completed chassis inserted from the front, which is then bolted by the screws supplied to the cabinet. A hinged lid gives easy access to the inside for adjustments, etc. Louvres are provided in the sides and the back for ventilation.

These cabinets are made in two sizes, one measures 8½ in. x 9½ in. x 9½ in. high, and the other 17 in. x 9½ in. x 9½ in. high, the prices being 16s. 6d. and 25s. respectively. They are strong and well made, and finished in crystalline black enamel.

ERKA TOROIDAL MAINS TRANSFORMER

OF the several ways of arranging the windings on a coil so that it shall have the smallest possible external field the toroidal method is possibly one of the most satisfactory. Owing to the large number of

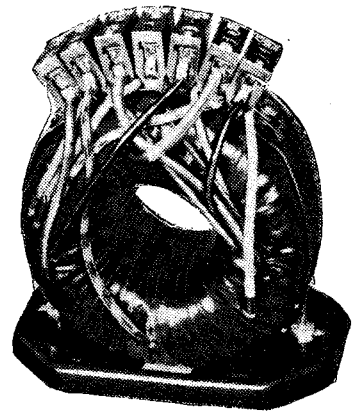

A ring-type core and toroidal windings are used in the Erka mains transformer.

turns on a mains transformer the constructional difficulties generally preclude its adoption, since manufacturing costs are considerably higher than with the more orthodox assembly. Toroidal windings on a ring core are adopted, however, in the Erka range of mains transformers distributed by F. W. Lechner and Co., Ltd.

The external field, which is due mainly to magnetic leakage, is so small with the Erka product that intervalve transformers, output chokes and the like can be mounted close to it, and very little mains hum is picked up. By suitably positioning the latter this can be reduced to a negligible amount.

Whilst induced mains hum can be avoided under similar conditions with an orthodox wound transformer, the position for minimum pick-up is far more critical even though the two components be well spaced.

Occasions often arise when a transformer with a negligible external field would be invaluable and the Erka model will meet these requirements admirably.

The model tested had two LT windings giving 4 volts each at 2 amps and 1 amp respectively. The secondary was rated at 250+250 volts RMS, the DC output after rectification being 60 mA. On full load, and with a 300-ohm smoothing choke and a 4 mfd. reservoir condenser, the DC output was 249 volts at 60 mA. The two LT windings gave 3.99 volts at 1 amp and 3.06 volts at 2 amps respectively. To obtain this output the 230-volt AC mains were connected to the 220-volt tapping on the primary winding.

The HT secondary regulation was most satisfactory, the full load voltage being only 4% below that on voltmeter load alone.

The price of this model is 67s., and transformers wound to any specification can be supplied.

New Apparatus Reviewed

Recent Products of the Manufacturers

points between minimum and maximum capacity.

Brass is employed for the frame and for the vanes, this being regarded as a suitable metal for use in the tropics. A flexible mounting may be found necessary in certain cases to prevent condenser microphony, as this is a prevalent cause of howling in selective short-wave superheterodynes.

The two- and three-gang models of this condenser cost 10s. 6d. and 16s. respectively. A single condenser embodying the same useful features is available also at 5s. Its capacity is 0.00016 mfd.

EDDYSTONE METAL CABINETS

STRATTON & CO., LTD., Eddystone Works, Bromsgrove Street, Birmingham, has introduced a range of steel cabinets with welded joints and designed especially for housing short-wave sets, frequency monitors

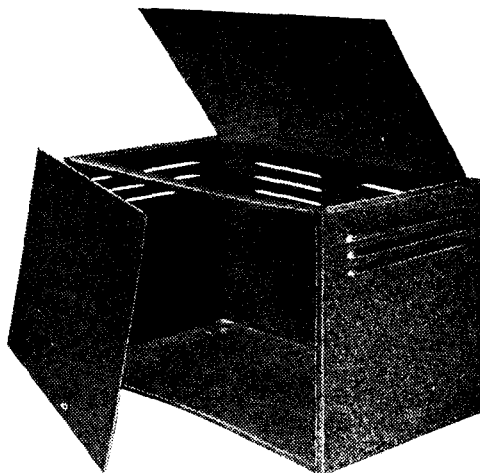

Eddystone metal cabinet with hinged lid and detachable metal front panel.

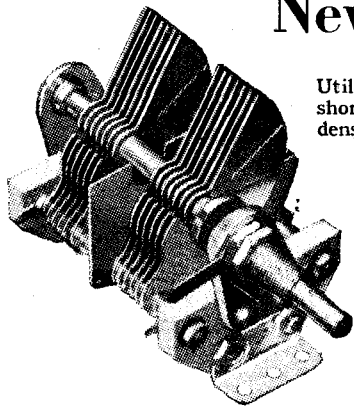

Utility two-gang short-wave condenser having carefully matched sections.

UTILITY SHORT-WAVE CONDENSERS

A SERIES of gang condensers designed especially for use in short- and all-wave receivers, and in which the same care is taken in the matching of the sections as is adopted in the standard broadcast types, has just been introduced by Wilkins and Wright, Ltd. The tolerance allowed is one m-mfd. or ½ per cent., whichever is the greater, and each section has a capacity of 0.00015 mfd.

The minimum of metal is included in the framework, and closed loops are avoided, yet it is sufficiently strong and rigid to ensure the retention of the initial matching. Frequentite insulating supports are used throughout and both stator and rotor vanes are securely bonded.

With the specimen two-gang model tested the difference in capacity of the sections did not anywhere exceed the makers' tolerance, as will be seen from the tabulated measurements below made at six different

Position	Capacity in m-mfds. Front Section.	Rear Section.	Difference in m-mfds.
1 (Min. cap.) ...	6.8	6.0	0.8
2 ...	19.1	19.0	0.1
3 ...	69.0	69.0	—
4 ...	103.8	103.8	—
5 ...	132.3	132.6	0.3
6 (Max. cap.) ...	154.0	153.5	0.5

BROADCAST BREVITIES

Henry Hall's "Guess" Nights

ALTHOUGH, by arrangement with British Equity, Henry Hall's Guest Nights are coming to an end, when one gate shuts another opens.

Let me whisper that on October 12th Henry Hall will substitute another special feature which will add mystery, not to say romance, to the late dance music on Saturday nights. In fact, they will be Guess Nights.

If I were to tell you more . . . but already I have said too much.

Fly in the Ointment

On the entertainment side the Guest Nights have been a success, but there has been a feeling in some circles that the fact that the guests are not paid has given a touch of irregularity to the proceedings which, in a less well-conducted establishment, might have paved the way for what is vulgarly termed "graft."

The B.B.C. Orchestra

DR. ADRIAN BOULT deserves well of his countrymen. A crowning honour is to come to the B.B.C. Symphony Orchestra, which his careful nurture has raised to the status of having an international reputation, for I hear that the Orchestra may be invited to take part in next year's Salzburg Festival.

Plans are already in hand for a tour of the European capitals. Probably the Orchestra's first visit will be to Paris as guests of the State Broadcasting System. A call may also be made at Brussels, and in all probability a visit will be paid to Berlin.

New Music Assistants

Now that he is to be relieved of administrative duties Dr. Boult will be able to concentrate still more on the perfection of the Orchestra. Mr. Kenneth Wright has been appointed as an Assistant Director of Music, and Mr. Maurice Johnstone and Mr. Edward Clark have been made chief organisers of the concert programmes.

On Top of the Gunpowder

Incidentally, the Music Department, or nine-tenths of it, has vacated Broadcasting House, and is now installed on the upper floors of Brock House, Great Portland Street.

The lower floors are still devoted to the fireworks business, and the thought of so much gunpowder such a little

By Our Special Correspondent

distance beneath them has given the members of the Music Department a new interest in life.

International Sunday

IT will be a busy Sunday for control engineers and linesmen all over Europe on October 27th, for on that day the first of the International Broadcasting Union's specially arranged features, "Youth Sings Over the Frontiers," is to be relayed to and from most of the more important broadcasting centres of the world.

Difficult Dovetailing

The songs are to be contributed for the most part by students and typical groups of country people, each group performing on its native heath. The task of the producers, both

specially selected charwomen storms Broadcasting House at 6 a.m. each day. They scrub 1,750 stairs, clean 107 mirrors, and scour 150 wash-basins; each wash-basin has two taps, so 300 of these have to be polished.

Brown-smocked male attendants fill 140 toilet soap powder bottles. (The users of ten of the wash-basins are entrusted with soap tablets.)

Gargling Permitted

The war on anti-broadcasting bacteria is fought with tall bottles of purple fluid and a pile of cardboard drinking cups in each wash-room. Gargling is not only permitted, it is encouraged.

Before I grow tedious just let me tell you that Broadcasting House has 6,500 electric light bulbs.

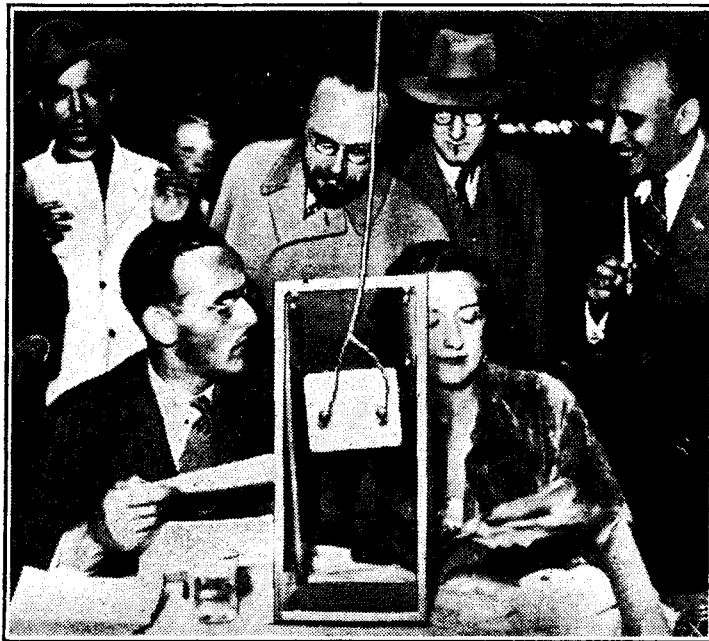

NIGHTFALL IN BUDAPEST found Eric Maschwitz in serious mood when this photo was taken during one of the recent B.B.C. broadcasts from the Hungarian capital. Miss Frances Clare is his companion at the microphone.

technical and studio, will be so to dovetail the respective items that listeners will be able to imagine that the whole concert is proceeding from a single studio.

The B.B.C. contribution will comprise three songs, two to be given by an anonymous choir of boys and girls, and the third by a troop of Boy Scouts.

Statistics

EVERY listener should have a few statistics to study during those increasingly long intervals between items in the B.B.C. programmes.

So here goes. An army of 114

Pig Tale

A PIG played an important part in a radio drama recently enacted in an Assam village.

In a letter to the B.B.C. Empire Department a District Officer wrote: "A Naga came and heard my set from a village where I had not previously taken it. I got him to listen in. He was delighted. He returned to his village.

"About a month later he turned up again and asked for a summons against the elders of his village. He explained that after hearing the wireless he had returned home and told every-

body about it. A few days later he had been summoned by the village council and fined a pig for telling lies. The elders duly turned up and I made them listen, and I later got a report that the pig had been returned."

Why He Trembled

A correspondent in Nauru Island, Central Pacific, wrote: "My house-boy is at present standing with his mouth open and trembling at the knees because I have pointed out London to him on my map and explained that the music is coming from there."

The poor boy had thought London was civilised.

Football Broadcasts

FOOTBALL enthusiasts, whether they prefer the circular or oval ball, are well catered for during the forthcoming season. For lovers of "Soccer" there is a relay from Highbury on October 29th, and a running commentary on the second half of the F.A. Charity Shield Match will be broadcast. The Oxford v. Cambridge Association football match will be relayed also from Highbury on December 11th.

"Rugger" Relays

The "All Blacks," the famous New Zealand "Rugger" team who are at present on a visit to this country—will figure in no fewer than three broadcasts—against Scotland at Edinburgh on November 23rd, Wales at Cardiff on December 21st, and finally against England on the Twickenham ground on January 4th. Twickenham will also be the scene of commentaries on the Oxford and Cambridge match (December 10th), the annual Army and Navy tussle on March 7th, and the international game between England and Scotland on March 21st.

Other international matches which listeners will be enabled to follow are those of Wales v. England (January 10th), Scotland v. Wales (February 1st), and Wales against Ireland on March 14th.

Another Serial

"BILL" HANSON, who is producing the new "Saturday Magazine," has, I hear, procured the services of Joseph Renaud, the French Edgar Wallace, to write a special version of his "Scarlet Orchid." This thriller will be adapted for the "Magazine" by John Watt and will be broadcast in instalments on the lines of "The Mystery of the Seven Cafés."

Comedy will be in the hands of famous funny men.

Automatic Selectivity Control

Self-adjusting Circuit for Varying Conditions

By R. I. KINROSS

WHAT the author graphically describes as a "sucker" circuit is caused to increase the high-note of a receiver when strong signals are being received. For reception of weaker signals, on the other hand, the absorption effect is progressively and automatically reduced until practically full selectivity becomes available

THE recent introduction of variable selectivity, a virtual necessity in these days when a compromise must always be struck between quality and selectivity, has brought about an additional complication which is apt to bewilder the non-technical listener. This article describes a method by means of which a compromise between high-note response and selectivity is obtained automatically, the strength of the signal itself deciding which of these two properties is the more important in the prevailing circumstances.

The principle used is simple and easy to understand: A low-loss circuit, tuned to the IF frequency, is tightly coupled to one of the circuits of the IF amplifier in a superhet receiver. It will therefore absorb at the IF frequency and so turn a sharp overall resonance curve into one with a more or less flat top, in the manner shown in Fig. 1. The degree of absorption is regulated by varying the damping of the absorbing tuned circuit. The anode AC resistance of a triode is used for damping and the degree of damping is adjusted automatically by joining the grid of the triode to the source of AVC potential, as that AC resistance is controlled by the signal itself.

It will thus be seen that, for strong signals, a high negative bias will increase the impedance of the valve, increase the absorption, and so flatten the top of the resonance curve; for weak signals, the opposite effect will take place.

Suitable Valves

The type of valve used for controlling damping will depend on the AVC voltage available. The important point is that its anode AC resistance should fall to about 10,000 ohms for weak signals and rise to a megohm or more for signals of ten millivolts or over.

An MH41 valve with 60 volts on its anode will be found to fulfil these conditions for a change of only $2\frac{1}{2}$ volts bias on its grid. An MH4 will do the same for a change of about 4 volts, provided the anode volts are kept low.

In the particular case for which the measurements of Fig. 1 were taken, the "sucker" coil was $\frac{3}{8}$ in. away from the grid tuned coil, but as this spacing

depends so much on the kind of coils and size of cans used, the experimenter can most easily determine the best position for himself by trial. He should first tune the sucker coil to the intermediate frequency. This is best carried out in the following manner.

Tuning the "Sucker" Circuit

Temporarily take the grid of the damping valve to a steady source of negative bias sufficiently high to stop the flow of anode current. After tuning in a weak signal, loosely couple the sucker coil to the grid coil and tune the former to the point where the signal is weakest. Next reduce bias on the damping valve so that its impedance falls to 10,000 ohms and increase the coupling between the sucker and grid coils as much as possible without impairing the sensitivity and selectivity of the receiver.

If now the bias be increased again it should be found that a considerable increase of top response has been obtained.

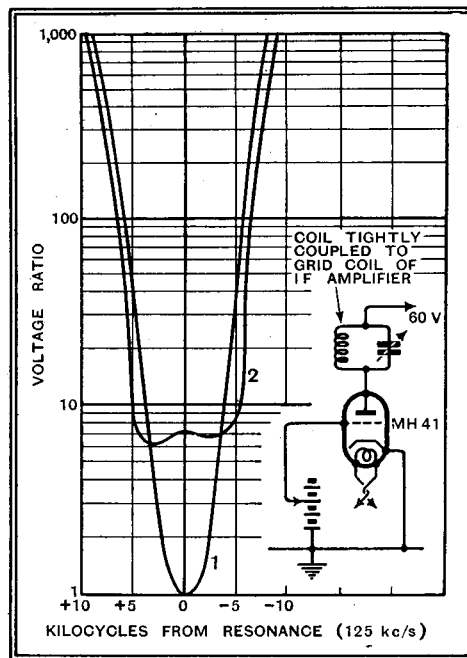

Fig. 1.—Improving high-note response by coupling a "sucker" circuit to the I.F. amplifier. Curve 1 represents normal high-selectivity adjustment, with zero bias on controlling valve; curve 2 shows the effect of increasing bias to $2\frac{1}{2}$ volts.

If the selectivity curve has become seriously double-humped or quality sounds peaky, the coupling coefficient of the IF tuned circuits of one or more of the IF filters should be reduced so that a reasonably flat-topped response curve is obtained. In this way it will be found that not only has the selectivity on distant signals been improved, but better top response will be obtained on the local stations. No fears need be entertained of

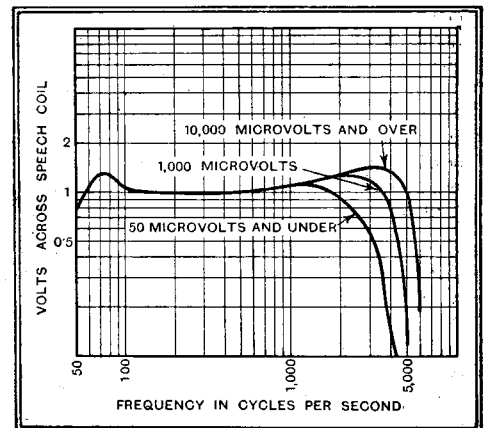

Fig. 2.—Overall response curve, at 300 metres, showing extent of automatic control of high-note response for weak, medium, and strong signals.

over-coupling the sucker coil if the above procedure be carried out. Finally, the bias of the damping valve should be taken to the source of AVC, or to such a proportion of it as will fulfil the conditions outlined when discussing the type of valve to use.

Manual Control

It will be advantageous to fit a pre-set sensitivity limiting device if the receiver has not already got one. By means of this it will then be possible to control by hand as well as automatically the quality and selectivity of the receiver, which at times may be found advantageous. For instance, suppose one evening interference is very bad and the sensitivity be limited to, say, 1 millivolt. This, apart from reducing the noise while tuning if the receiver is not fitted with a "Q" device, will also reduce the background noise on signals of, say, 5 millivolts, which, on a favourable evening, it might be possible and desirable to listen to at full top response.

I have to acknowledge with thanks the permission of the Gramophone Company to publish data in connection with this device.

Listeners' Guide

Outstanding



SUNDAY IN EGYPT. A direct relay from Cairo, to be heard in the National programme at 5.30 on October 6th, will include a sound picture of a Cairo street. The Pyramids are not far from the city.

orchestra, conducted by Mustafa Rida Bey, President of the Royal Institute of Oriental Music and famous as executant on the harp-like Kanoun. Other instruments to be broadcast will include the "Oud," the "Nai," and the "Rek." Ancient music played on reeds will precede a relay from a

written the book and lyrics, and Lubbock the music. I am told that listeners should look out for a Fast Waltz sung by members of the party in a cab on their way home from the cabaret. There is also a clever song sung by a soubrette in the cabaret itself.

Lubbock and Freeman seem to be qualifying as the Gilbert and Sullivan of broadcasting, and "Week End Return" will probably add considerably to their already high reputation.

◆ ◆ ◆

HANDEL RESUSCITATED

HANDEL was singularly unfortunate with his operas, many of which never passed the manuscript stage. One of these forgotten efforts was "Perseus and Andromeda," and it has been left to the B.B.C. to give the first performance of this opera on Tuesday next, October 8th (Regional, 9.5). The opera is constructed from music written by Handel for the Pastiche "Jupiter in Argos," which was intended for performance at the King's Theatre in May, 1739. The score has been arranged from a MS. in the possession of Mr. Newman Flower and from a portion of Handel's autographed score in the Fitzwilliam Museum, Cambridge, and the new libretto has been written by Professor Albert G. Latham.

The cast is to include Ina Souez as "Andromeda," Dorothy Stanlow as "Cassiopeia," Mahry Dawes as "Ianeiro," and Eric Greene as "Perseus." They will be supported by the B.B.C. Chorus and Orchestra.

BEGINNINGS AND ENDINGS

BROADCASTING, like life, seems full of beginnings and endings. Take to-morrow, which sees the ending of this year's Promenade Concerts and the beginning of "Saturday Magazine" and a new series of "Five Hours Back."

It is well that the B.B.C.'s scene-shifters should be constantly busy. A year of "Proms" would be agonising to players and listeners alike; probably an eight-weeks' season is just enough.

The B.B.C. is slowly evolving a technique which involves *tempo*, or "timing," as our film friends call it, whereby no form of entertainment outstays its welcome, whether it be a mystery connected with seven cafés, the confessions of guests in the metropolis after nightfall, or a talks series on the discontents of youth.

◆ ◆ ◆

SAXOPHONE ON SUNDAY

THE saxophone comes into its own as a serious musical instrument this week-end. In the Promenade Concert to-morrow Sigurd Rascher will play the solo part in the first concert performance in England of a Concerto for Saxophone and Strings by L. E. Larsson.

Sigurd Rascher will also give a saxophone recital in the National programme at 9 p.m. on Sunday, and will include

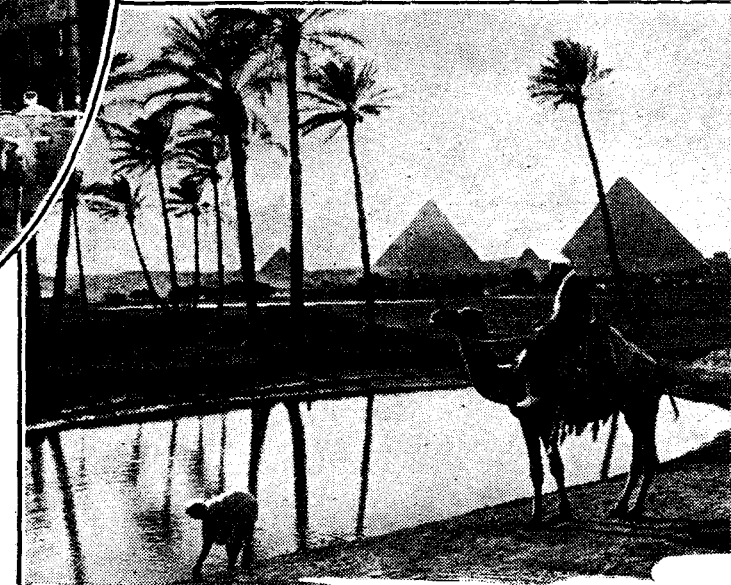

Handel's Sonata in F—not written for the saxophone, but very adaptable to that maligned instrument.

SUNDAY AFTERNOON IN EGYPT

ALL kinds of unfamiliar instruments will be heard in Sunday's relay from Cairo which the B.B.C. are carrying out at 5.30 in association with the Egyptian State Broadcasting Organisation.

After the opening announcements there will be a reading from the Koran by Sheikh Mohammed Rifaat. This will be followed by a performance by an Oriental takht, or

Cairo street. Finally, Umm Kulthum, described as the "Melba of the Orient," will give a recital, followed by a pianoforte rendering of Eastern music by Nidhat Assem, and orchestral music presented by Hassan el Shogai.

◆ ◆ ◆

NEW MUSICAL SHOW

A PARTY of English people in Paris embroiled in some laughable situations supplies the theme of "Week-end Return," a musical show by Mark Lubbock and Denis Freeman, to be broadcast in the Regional programme on Monday at 9. Freeman has

THE LAST OF THE "PROMS." To-morrow night listeners will hear the annual ritual associated with the final concert of the season. Sir Henry Wood's Fantasia on British Sea Songs—the last item—and the National Anthem precede a gale of applause persisting long after the microphones are faded out.



or the Week

roadcasts at Home and Abroad

SCHUBERT IN THE "FOUNDATIONS"

SCHUBERT'S early songs, sung by Herbert Heyner (baritone), are to be given in this week's "Foundations of Music" series at 6.30 (National).

"THE CIRCLE"

A SOMERSET MAUGHAM play is an "event," whether in a stage or broadcast version. On Wednesday and Thursday next Maugham's drama, "The Circle," is to be given in a broadcast production arranged by Val Gielgud. Ronald Squire takes the part of Clive Champion-Cheney, and other members of the cast are Austin Trevor as Arnold Champion - Cheney, M.P., Carol Goodner as Elizabeth, and Eve Moore as Lady Catherine Champion-Cheney. The broadcast will be at 8 in the National programme on Wednesday and at 8.30 in the Regional on Thursday.

SAINT-SAËNS FESTIVAL

THE Saint-Saëns birthday centenary celebrations are still being observed on the Continent. To-morrow night Strasbourg, at 8.45, relays from Metz a Saint-Saëns centenary festival concert arranged by the Messin Musical Society. On Sunday morning at 11.45 Vienna broadcasts a Saint-Saëns concert by the Vienna Symphony Orchestra with Viktor Ebenstein as solo pianist and Franz Schütz at the organ. Kalundborg gives a Saint-Saëns festival concert at 8 p.m. on Wednesday.

HIGHLIGHTS OF THE WEEK.

FRIDAY, OCTOBER 4th.
Nat., 8, Beethoven Promenade Concert. 10.10, Memories of T. H. Huxley by H. G. Wells.
Reg., 8, George Graves in "Véronique." 9.15, B.B.C. Military Band.

Abroad.
Hilversum, 7.55, Concert by the Maastricht Municipal Orchestra.

SATURDAY, OCTOBER 5th.
Nat., "Six Hours Back." 7, The Saturday Magazine. 8, Promenade Concert—Last Night. ¶Ambrose and his Embassy Club Orchestra.

Reg., Unrehearsed Debate. 8.45, Jack Hylton's Radio Review.

Abroad.
Strasbourg, 8.45, Saint-Saëns Festival Concert, from Metz.

SUNDAY, OCTOBER 6th.
Nat., B.B.C. Military Band. 5.35, Programme from Egypt. ¶Saxophone Recital. ¶Commodore Grand Orchestra.

Reg., B.B.C. Orchestra conducted by Joseph Lewis. ¶R.A.F. Band. ¶Belfast Revisited by Robert Lynd. ¶London Symphony Orchestra, conducted by Sir Hamilton Harty.

Abroad.
All German Stations, 8, Harvest festivities.

MONDAY, OCTOBER 7th.
Nat., 8, "The Personality Machine" —variety hour. ¶Pianoforte Recital by John Wills.

Reg., J. H. Squire Celeste Octet. ¶B.B.C. Orchestra. 9, "Week End Return"—a musical show.

Abroad.
Brussels II, 8, Folk songs and Music of the Nations, relayed from the Exhibition.

TUESDAY, OCTOBER 8th.
Nat., 8, "Week End Return." ¶"Meet Mickie Mouse," by John Watt and Wally Wallond.
Reg., B.B.C. Military Band. 9.5, "Jupiter in Argos" (Handel).

Abroad.
Paris (PTT) 8.30, "Manon Lescaut as the Musician's Inspiration." French National Orchestra.

WEDNESDAY, OCTOBER 9th.
Nat., 8, "The Circle" (Somerset Maugham). ¶Italian Wine Harvest programme.

Reg., B.B.C. Dance Orchestra. 8, Chopin Recital from Warsaw. ¶Scots Music for baritone and orchestra (Soloist: Neil Forsyth).

Abroad.
All German stations, 7.15, Youth programme: Songs of the Seasons.

THURSDAY, OCTOBER 10th.
Nat., 8, Variety Hour. ¶Recital by Alphonse Onnon (violin) and Stefan Askenase (pianoforte).
Reg., Students' Songs. ¶B.B.C. Organ Recital by Maurice Vinden. 8.30, "The Circle."

Abroad.
Stuttgart, 8.30, A Robert Schumann Concert.

MUSICAL ORCHARD

A RIPE orchard with apples falling on every side will be suggested to the music lover who wanders through the European ether during the next seven days.

To-night the Vienna Singing Boys will be heard at Beromunster (8.15), and Munich is

dini's four-act opera "La Sagredo" at 8.40.

A novelty in operatic broadcasts is promised by Paris PTT at 8.30 on Tuesday. "Manon Lescaut," since it was written by M. l'Abbé Prévost in the eighteenth cen-



THOSE "CADS," the Western Brothers—Kenneth and George—will be heard in the National Variety programme on Thursday next at 8. They are here seen putting in a spot of practice at the nets.

giving a recital of Rhine literature and music (10.30). The harvest is the theme of a recital by the Königsberg Station Choir to-morrow evening at 6.20 and again on Sunday of an oratorio "Harvest Thanksgiving," to be given by a choir and wind orchestra from Kiel, to be relayed by Hamburg.

Organ music by Vienne will be relayed from the Carmelite Church (Brussels No. 1) on Tuesday, and on Wednesday Warsaw offers a Chopin recital at 8 which is being relayed by London Regional. On Thursday the celebrated carillonist, Arthur Bigelow, is giving a recital at St. Peter's Church, Louvain, to be relayed by Brussels No. II at 9.15.

OPERA ABROAD

TO-NIGHT finds opera lovers well catered for with two important relays from Metropolitan State Opera Houses. At 7.25 Vienna will relay Ponchielli's four-act opera, "La Gioconda" from the State Opera. This was produced at Covent Garden as long ago as 1883 "with much success" according to contemporary reports. Verdi's "Otello" is the other State Opera performance, being relayed by Prague at 7.30. To-morrow Rome offers Vitta-

tury, has inspired many creative artists, particularly in the world of music. Interpretations of four eminent composers—Auber, Hahn, Puccini and Massenet—will form this very interesting broadcast.

NEW STRAUS OPERETTA

To be able to tune in the premier of a new Oscar Straus operetta is a privilege to which many listeners will be eager to take advantage. At 7.50 to-morrow night Beromunster is relaying the first performance of "Three Waltzes" from the Zürich Municipal Theatre. Will "Three Waltzes" rival in popularity "The Last Waltz," "The Chocolate Soldier," and "The Waltz Dream"?

THREE FRANKFURT FEATURES

FRANKFURT offers three especially attractive programmes next week. On Tuesday at 8.30 there will be chamber music for brass instruments. At 11 on Wednesday Frankfurt shares with Stuttgart in one of the popular midnight concerts, this time with modern music for two pianofortes. And on Thursday the same station features "Spain in Music" with orchestral compositions by Ravel and Glinka.

THE AUDITOR.



Murphy TYPE A28C

Automatic Tuning Eliminates Sideband Distortion

FEATURES.—Type.—Console type superheterodyne for AC mains. No provision for gramophone reproduction. **Circuit.**—Var.-mu pentode HF amplifier—triode-pentode frequency-changer—var.-mu pentode IF amplifier—double-diode detector—pentode noise suppressor and LF amplifier valve—pentode output valve. Automatic tuning valves—double-diode rectifier and pentode reactance control valve. Full-wave power rectifier. **Controls.**—(1) Tuning. (2) Volume and on-off switch. (3) Waverange. **Price.**—£21 15s. **Makers.**—Murphy Radio, Ltd.

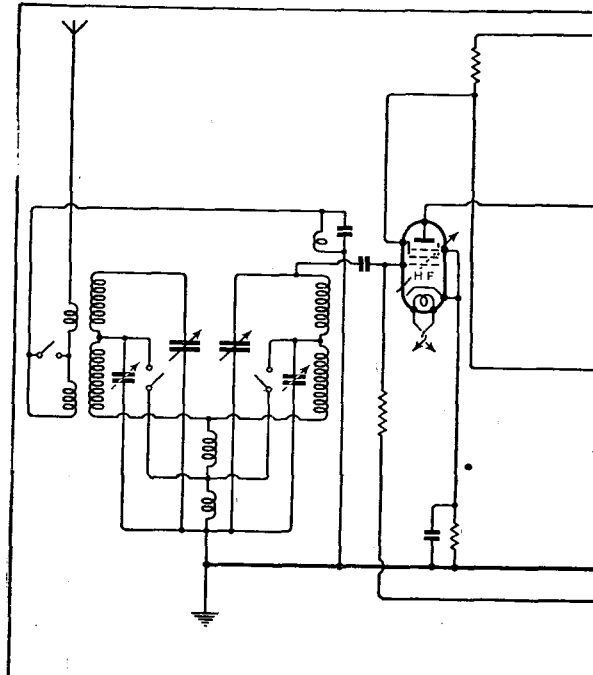

WHENEVER a new technical feature has been introduced by Murphy Radio it has generally resulted in a definite increase in what may be termed the entertainment value of the set in the hands of the ordinary non-technical user. Intriguing as are the details of the new automatic tuning circuit to the student of design it is the interests of the ordinary listener who just "turns on the wireless" that have been given priority in designing this set.

Under present conditions good reception even of the dozen or so Continental stations which can be regarded as of first-class programme value in this country, demands a high degree of selectivity. Any good superhet. will provide the listener with the necessary powers in this direction, but like a sharp knife they must be used with skill and competence, otherwise some part of the response necessary to good quality of reproduction will be cut off. The provision of tuning indicators is an admission that the majority of listeners require some aid other than the ear in estimating when a station is exactly in tune, and a set which relieves them of the necessity of concentrating on meters or spots of light is a logical step towards the realisation of the ideal trouble-free receiver.

The manner in which the A28C adjusts itself to compensate for errors in tuning is quite uncanny. Assuming that the set has been accurately tuned in the first instance by someone with a critical ear, deliberate mistuning at first results in the usual sideband distortion with a complete loss of bass and a reduction in volume. Gradually the volume increases and the balance of tone is slowly restored until the reproduction is in no way distinguishable from that obtained with the correct setting. There is an appreciable time lag, and on the set tested between 5 and 6 seconds elapsed between the instant of mistuning and the complete restoration of quality. A test was made to see whether there was any difference in quality after the set had readjusted itself from the extreme limit of the scope of the automatic tuning control, but although the experiment was

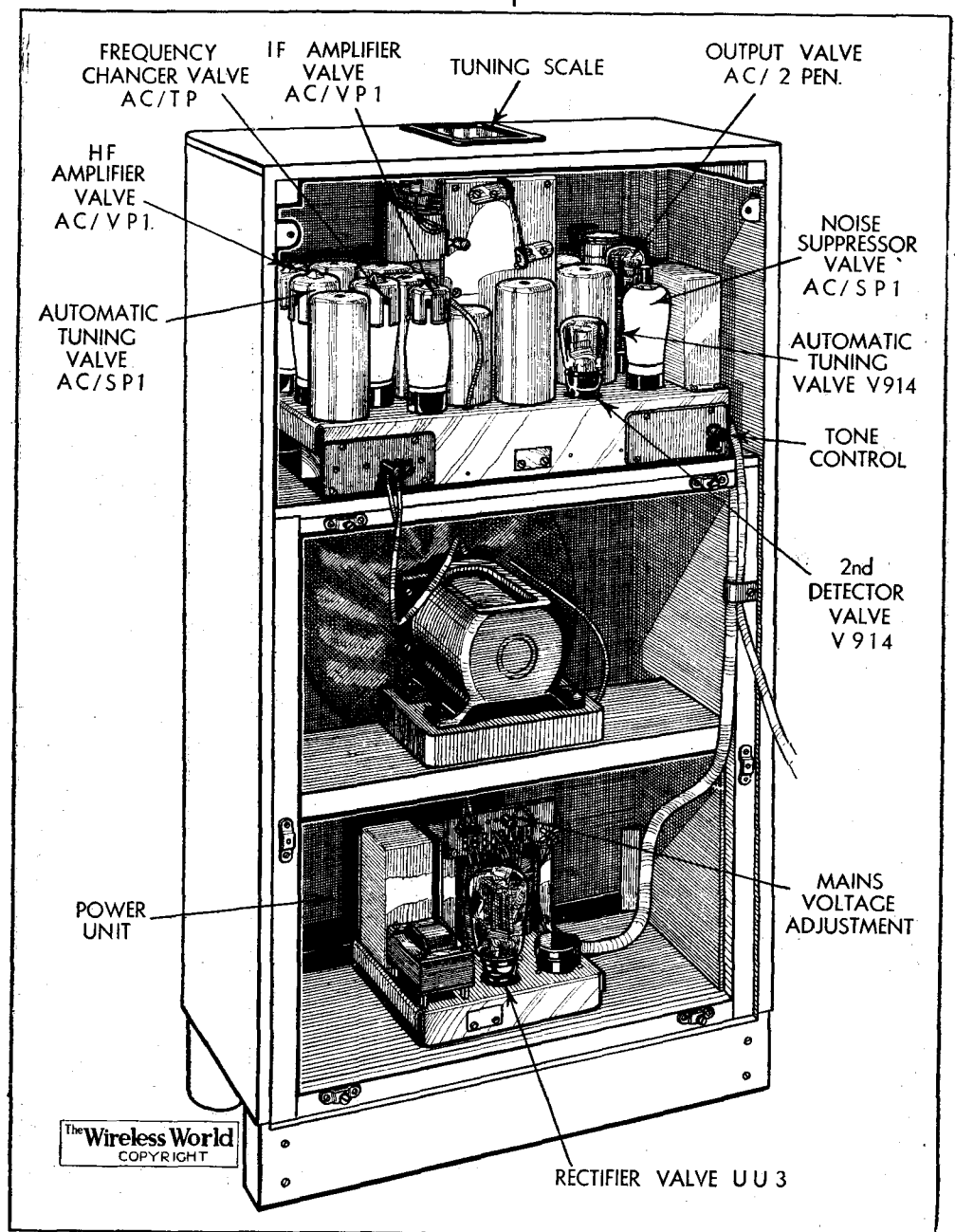

Under operating conditions the top and bottom compartments are backed with plywood panels. The loud speaker compartment, which is lined with sound absorbing material, is open.

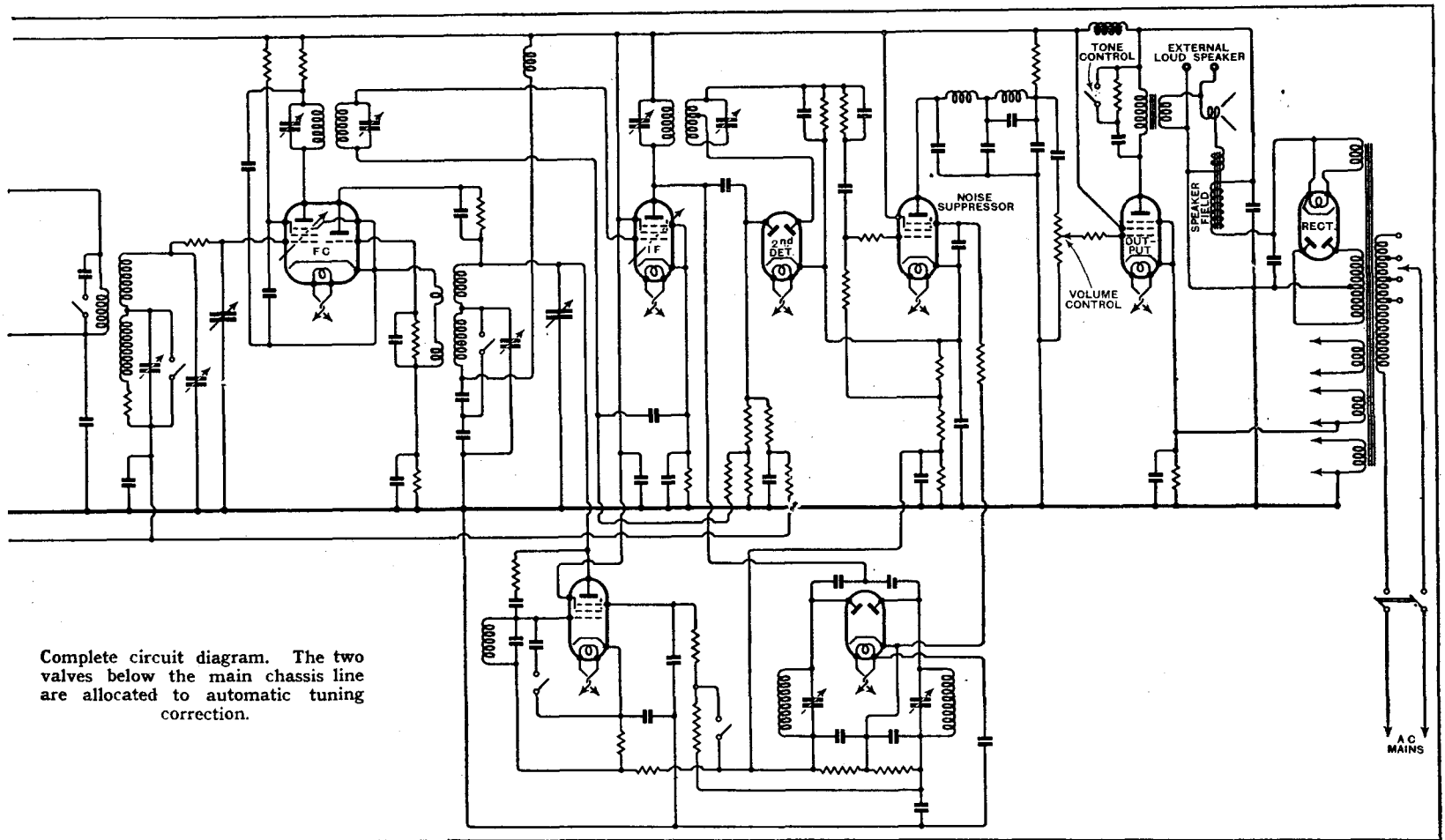

repeated a considerable number of times and on different stations, not the slightest difference could be detected. Once the set has settled down any movement of the tuning pointer, even towards resonance, results first of all in a falling-off of volume and quality before the circuits adapt themselves to the new conditions.

Effective Selectivity

The limit over which the automatic tuning is operative on any given station is roughly the same as that of the spread of the station as determined by the natural selectivity of the set. On the medium waveband this amounts to just under one channel on either side of the Brookmans Park transmitters when using the set in Central London. It was interesting to observe the behaviour of the set when tuned to a point midway between North Regional and Langenberg. Before the automatic tuning took control a background of equal strength could be heard from both stations, but after the usual interval one or other station would take command and the interference from the other station would disappear. This can be regarded as an addition to the effective selectivity, if selectivity means the suppression of interference with the unwanted programme.

The automatic tuning circuits

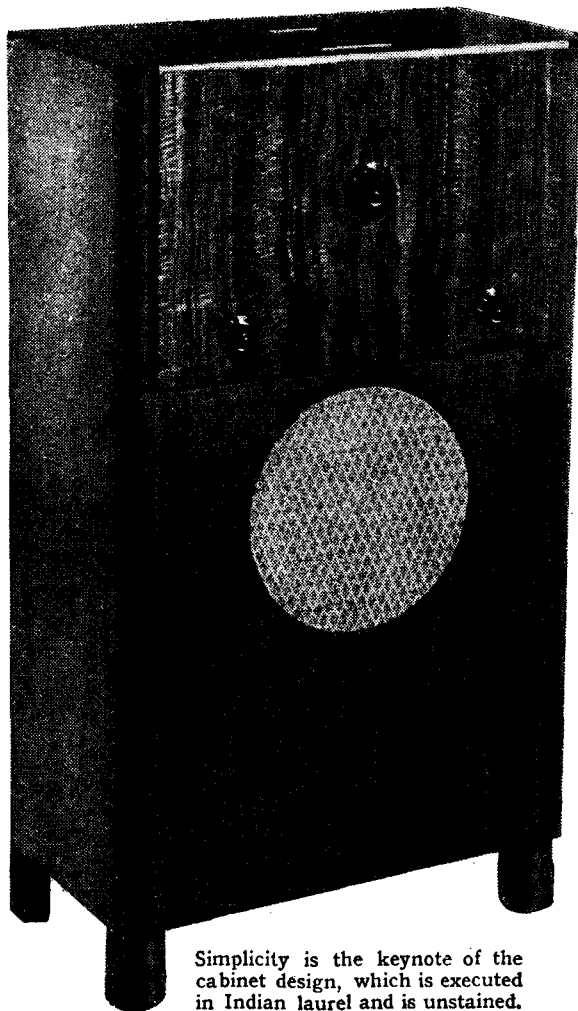

Simplicity is the keynote of the cabinet design, which is executed in Indian laurel and is unstained.

are entirely electrical in operation, and the principle of operation may be summarised as follows:—Part of the output from the IF stage is impressed on two "control" circuits, one of which is tuned slightly above and the other slightly below the correct intermediate frequency. The two elements of a double-diode valve are arranged to rectify any voltages which may be developed in these circuits and to put these currents in opposition. The magnitude and sign of the resultant current will depend on whether the beat frequency passing through the IF stage is above or below the correct frequency. This current is used to bias the second control valve, an HF pentode, and so to vary its slope. Circuits are associated with this valve which make its anode to cathode impedance reactive. This reactance is connected across the oscillator circuits in the frequency-changer stage and the circuit is so arranged that the change in the oscillator frequency brings the beat frequency with the incoming signal back towards resonance with the main IF circuits. It does not quite reach resonance as some difference in frequency is necessary to produce the correcting voltage, but in general the error will not exceed 0.5 kc/s, which is too small to have any effect as far as the aural results are concerned.

Obviously, with the automatic tuning circuits always in operation it would be impossible to calibrate the tuning scale accurately, or to move from a powerful station to another on an adjacent channel. Accordingly, a switching arrangement has been incorporated in the drive to the main

Murphy Type A28C

ganged condenser, which cuts out the automatic tuning circuits while the control knob is being rotated. As soon as the motion is stopped a spring releases the switch and the automatic tuning valves come into action. The time lag has been introduced to cover the period during which the switch is opened.

In common with previous Murphy sets the range of AVC leaves nothing to be desired. Interstation noise suppression has now been added and is of a type which is free from distortion on weak stations. The pentode valve following the second detector is set aside for this purpose and receives its controlling bias from the double-diode automatic tuning valve. A negative bias is applied to the *outer* grid of the pentode, and the advent of a signal causes this bias to be reduced to zero, so that the valve then functions as a normal amplifier. A heterodyne whistle filter identical with that used in the earlier "26" model is associated with this valve.

Letters to the Editor

The Editor does not hold himself responsible for the opinions of his correspondents

Crystal Sets

IN a recent issue of your paper "Diallist" asks if the crystal set is dead, and I feel that you may be interested to hear that there is one listener who did think so until recently.

On exploring a chest of drawers full of out-of-date radio parts, I unearthed a crystal set which had been preserved mainly as an interesting relic of the early days of broadcasting which would some day be quite a curiosity. As the radio section of my homemade radiogram was out of commission I was tempted to couple this minute set, which originally cost 5s. or 10s., to the input of the six-watt quality amplifier and the result is most gratifying.

Although, of course, only one station can be received (Droitwich) the sound is practically flawless, the whole musical scale being reproduced most naturally as are voices which might almost be in the room. One important thing contributes largely to this delightful effect, there is no audible background, and when the carrier wave is not being modulated it is indeed difficult to know that the set is operating.

A completely silent background has to be heard, or rather not heard, to appreciate its importance. The "deception" of radio is greatly enhanced when sound, be it speech, music or noise, from the reproducer reaches ones ears pure and unadulterated by any other sound.

Swindon.

W. J. PATERSON.

ABOUT four to five months ago some correspondence started in our local paper re the impossibility of receiving the long wave station, Droitwich, on a crystal set.

The B.B.C. said it could be done and the starter of the correspondence said it could not.

He went as far as taking his old-fashioned set to the local B.B.C. station and making them eat their words.

At this time I began to get interested, so I built up a set, very roughly, and found

Next Set Review—**WAYFARER PORTABLE**

In other respects the circuit follows the general lines of its predecessor.

The proportions and lining of the cabinet have been designed to eliminate cavity and wood resonances, and the bass reproduction from the massive moving coil loud speaker is far superior to that of the average set. There are no obvious vices in the middle and top, and, if a high-note cut-off is detectable in certain sounds, such as hand-clapping, the general reproduction does not suffer by comparison with so-called "high-fidelity" equipments. The reproduction of pianoforte tone in particular is most realistic.

The clean workmanship of the chassis and the cabinet finish maintain the high standard set by previous Murphy productions.

that even with my poor aerial, 35ft. long 8ft. high, it could be done.

I wrote to the local paper, thinking one or two people might be interested, and said it could be done quite easily and anyone might try my set. Little did I think what the result of that letter would be.

On the evening my letter was published people started coming at 6.15 and the last caller came at 9.15.

I then sat down and wrote to the paper cancelling my offer to hear my set. I offered instead to send any party interested a diagram. Incidentally, at one period during the evening I had to give people chairs on my front lawn whilst others were inside listening to the set.

The demand for diagrams came in by every post for several days, so that I handed all correspondence to a radio shop in the town to do what they liked in the matter, as almost all those who called on me had asked me to make them a set.

This is what really interested me, however, the class of caller.

There was no class. Rich people in their cars, ladies with their companions, music teachers, retired colonels, retired business men, ladies with limited incomes living in rooms, and in flats, young fellows of the shop assistant type, representatives from wireless shops, representatives of bed-ridden men and women, but, with one exception, a boy of 13, no one under about the age of 25.

They all wanted the same thing, the National and Regional stations on a crystal set, nothing more.

If I experienced all this through one letter in the Press and in one town, it is obvious that there is a real demand for a good crystal set. The demand I find is sometimes discouraged, as, naturally, there is more profit in a valve set.

I think you would be doing a good turn to thousands if you could design, and have made, the most efficient coil possible and then get out a design for the whole set.

I find that most people would pay two guineas for a really good set.

With a suitable wave trap one can have Radio Normandie as well as our local station at quite good strength.

A large number of people, I find, cannot get on with the catwhisker, some cannot see it, others have not the necessary delicacy of touch; an energised crystal would seem to be indicated.

Bournemouth.

R. C. STONE,
Mem., R.S.G.B.

Quality at the Show

THE letter from Mr. Noel Bonavia-Hunt in the issue of September 6th represents fairly the impression gained by most quality seekers at this year's Exhibition.

It seems to me that the difficulty is largely due to the enormous variation in the characteristics of the speakers forming the load on the common feed.

This should be avoidable by calling on the common feed to supply, not power, but the voltage necessary to drive a small power stage, like the output stage of many *Wireless World* receivers using a Class A triode of the type variously described as PX4, LP4, PP3/250, etc., working well within its capacity.

One unit only should be permitted to each stand, and makers wishing to demonstrate more than one speaker should adopt the switchboard arrangement used on the Wharfedale stand this year.

It should be possible to arrange that each unit gives approximately straight-line output from 50 to 8,000 or 10,000 cycles per second, and as each unit would have a pre-determined output, the resulting loudness of the speaker would be a rough index of its sensitivity. By permitting only one speaker to be at work on each stand at any one time, the general noise level would be reduced, and each speaker could be better heard.

A. E. FRANCIS.

Tadworth, Surrey.

Preventing Interference

MY experiences with a fan motor (40-watt rating, 1,420 r.p.m.) may interest some of your readers.

In all conventional series-wound motors the current transverse the two field coils and then the armature via the brushes. I decided to try the effect of connecting the armature *between* the field coils; by this method the brushes would be isolated (from the HF point of view) from the mains.

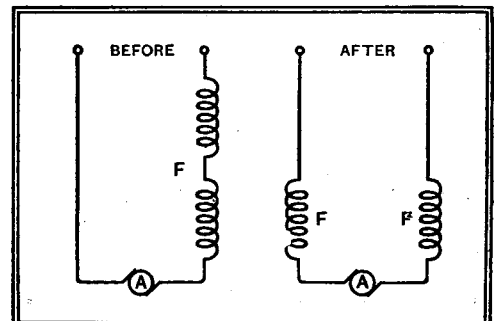

Re-arrangement of field coils FF to minimise radiation of interference produced at the commutation A.

The results of this modification were very gratifying; the fan originally interfered with any mains set for about 100 yards around, but now I can operate my AC Monodial about a yard away from it without any trace of mains interference. This without any filter on the fan or any kind

of alteration. I find that earthing the frame brings the interference in again mildly, but taking the frame to one of the brushes via a 2-mfd. condenser takes away the last vestige.

London, E.C. J. HELPS.

[The field coils, disposed in the manner described by our correspondent, undoubtedly act as chokes, preventing the radiation of interference due to sparking at the brushes. The alteration in question was advocated by a contributor to our pages some years ago.—Ed.]

Output Values

I READ with interest the letter from Mr. M. G. Scroggie appearing in your issue of September 6th in reply to my letter which commented on his article which appeared on July 5th.

Examining Mr. Scroggie's figures and graphs in detail and those of his original article, it would appear to me that they themselves prove very thoroughly the very contention which Mr. Scroggie feels they disprove.

I have not for one moment denied that, by driving into positive grid voltage, a greater power output and AC-to-DC efficiency may be obtained, but this increased output is only obtained at the cost of considerable distortion not otherwise present.

Mr. Scroggie shows in his letter some results of measurements of a triode valve which is driven slightly positive. He then shows, in his Fig. 2, some measurements of mutual conductance as a function of grid voltage for Class A conditions (marked A), and for a drive slightly into the positive region (marked B). May I point out that it is not correct to say, as Mr. Scroggie does, that the distortion is the same for both lines A and B? In fact, that associated with B corresponds to a very considerable third harmonic content not present in the case of A. (Actually I feel that Mr. Scroggie's calculations are somewhat at fault where he shows a slight drop at the left-hand end of the line A for the Class A triode. I have measured many valves and have never found any such effect, nor do I know of any theoretical reason why it should occur.) Referring to Curve B, immediately the grid voltage goes into the positive area, the mutual conductance begins to fall. Mr. Scroggie, apparently, thinks that this is a good thing because he says, "In consequence, the proportion of drop is rather less than line A," i.e., overall drop over the total length of the load line is less. Actually, however, harmonic analysis will show that the drop at the left-hand end of Mr. Scroggie's Curve B corresponds to the production of strong "third harmonic distortion," which is a far more objectionable type of distortion than the second harmonic kind which may be considered as the measure of the type of distortion produced by a sloping curve which does not turn over at the left.

Mr. Scroggie neglects altogether another source of distortion which is virtually negligible under Class A triode conditions, but becomes progressively more serious as the valve is driven into the positive region. This is due to the fact that the load of a loud speaker is by no means constant. With a correctly operated Class A triode, the lowest loud speaker impedance (at medium frequencies) is made equal to the "optimum" load of the valve. Then, at those other frequencies at which the loud speaker impedance rises, the distortion pro-

duced by the Class A triode is actually reduced. This is shown very clearly by Fig. 1 herewith, which shows curves of mutual conductance plotted along the load line for the optimum load of a typical triode and for a higher load. The latter curve is

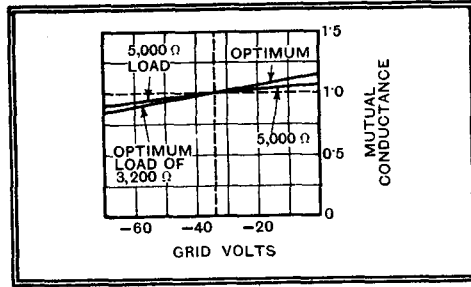

Fig. 1.

the flatter of the two. Now consider the case of the positively driven valve. Even when it is driven only very slightly positive (as in Fig. 1 of Mr. Scroggie's letter) the grid voltage lines close up substantially towards the left hand ends and, therefore, a slight rise of load produces a sharp fall of mutual conductance at the left hand end of the load line (see Mr. Scroggie's Fig. 2), or (in more usual terms) a violent increase in "third harmonic distortion."

It will not be unfair to read the queried paragraph of Mr. Scroggie's original article in the light of its context about the 6B5 valve he was then engaged in describing. In fact, this was what I did. Fig. 2 shows the makers' published anode voltage/anode current characteristics and shows the recommended load line. The grid voltage lines are those corresponding to voltages on the first grid. The characteristics, therefore, completely show the over-all performance

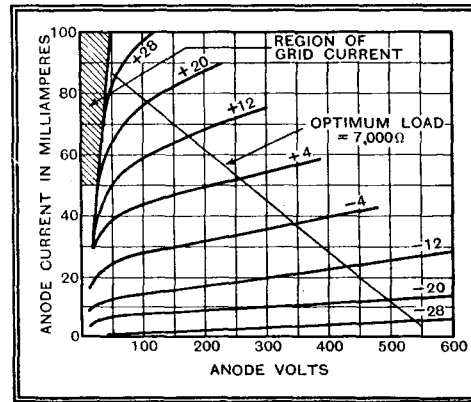

Fig. 2.

of the entire double valve. (Grid current is most ingeniously balanced out and, therefore, does not affect the result.) The fact that the second control grid is driven positive (even when the first is negative) must produce the type of characteristic having a "knee," and it will be seen that the mutual conductance is very far from constant along the load line, and that very pronounced "third harmonic distortion" is produced. According to the makers' published data, the 6B5 gives, under the conditions illustrated in Fig. 2, a third harmonic of about 4.2 per cent., and a second harmonic of about 2 per cent. Under push-pull conditions second harmonic is cancelled out. With two Class A triodes in push-pull the third harmonic is negligible and the total harmonic content under these conditions is therefore also negligible. With the 6B5 second harmonic is, of course, cancelled out

in push-pull, but a third harmonic remains of about 4 per cent. at the optimum load, rising considerably at higher loads. The mutual conductance of the 6B5 is plotted against grid voltage for various loads in Fig. 3. This shows exactly the distortion described in the third paragraph of my letter. The curve for a typical pentode at the optimum load is also shown dotted. (Pentode curves are given in full in an article of mine which appeared in your issue for August 2nd last.)

I feel convinced that a Class A triode is a suitable standard and is much superior to any arrangement in which the grid is driven positive. I do not mean to indicate that it is impossible by any other means to obtain an equal linearity to that of the Class A triode, or that it is the best to use in all circumstances; but I do think that it is of

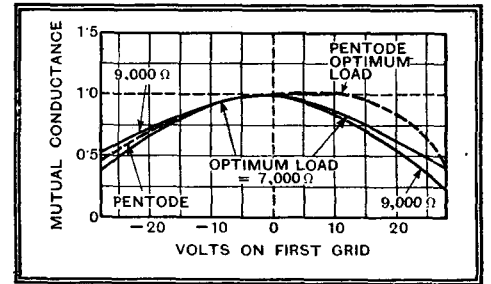

Fig. 3.

importance that the considerations affecting distortion in output valves be set out clearly and that some sort of standard of comparison is desirable.

J. H. OWEN HARRIES.
Frinton-on-Sea.

"Air King" Receivers

ARRANGEMENTS have been made to market these American sets in this country through the G. & C. Distributing Co., 115, Shaftesbury Avenue, London, W.C.2. The model illustrated is the 213, and is a 9-valve superheterodyne covering three waveranges, viz., 14 to 52, 175 to 565, and 930 to 2,250 metres. There is a signal-frequency HF stage working on all three ranges, and the push-pull output is designed for an undistorted output of 8 watts. The price is 20 guineas.

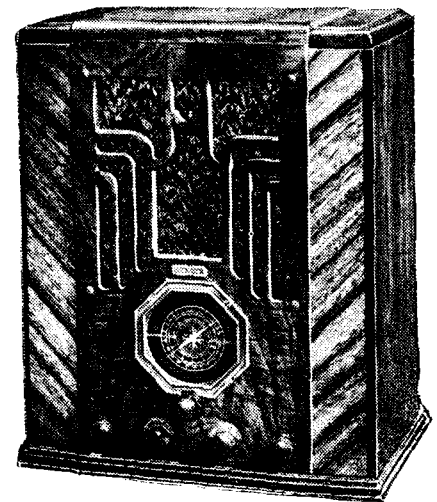

Model 213 "Air King" all-wave AC superheterodyne.

Random Radiations

Leipzig Again

BY the time that you read these notes the 120-kilowatt Leipzig transmitter may be in action again on 382.2 metres. During the greater part of the summer the service has been taken over by the old low-powered station since the whole aerial system was under reconstruction. Leipzig now has an anti-fading aerial of the latest type, such as all the other German high-powered stations already possess. If this aerial proves as satisfactory as the others the radius of Leipzig's service area will be very largely increased.

Fading at comparatively short ranges is unfortunately rather prevalent amongst some of our own stations. The "Little Nationals," synchronised upon 261.1 metres, fade badly in some places now that their power is only 20 kilowatts a piece. Even some of the Regionals with longer wavelength and higher power are not too good at distances over 60 or 70 miles.

The Autumn Overhaul

IN a short while from now we shall be enjoying the very best part of the year for long-distance wireless reception. Everybody wants to hear foreign stations; everybody nowadays can receive a certain number of them, but many people, as I know from experience, limit the repertoire of their sets and give them no fair chance of making the best of distant transmissions by neglecting to keep the receiver and the signal-collector system which feeds it in efficient condition. Take valves to begin with. Again and again I find people boasting that they have had the same set of valves in use for an almost incredible tale of years. There is no question that valves—and particularly battery valves—may sometimes continue to work in some kind of way for amazingly long periods; but it must be remembered that the valve, which is a wonderfully delicate piece of apparatus, is designed to give of its best for about one thousand hours, or, say, a year's working at three hours a day. Should your valves have a longer record than this it is as well, if you want the best from your set, to test them out yourself, or to have them tested for you if you have not the appliances for doing the work yourself. When such a test is made it is often found that, though the bulk of the valves may still be in fair order, there is one which is on its very last legs. To go on using such a valve means that you are missing a very considerable part of the entertainment and adventure that wireless has to offer. A replacement is not a very expensive business, and, when you remember that the cost is spread over a year, it is surely well worth while.

Aerials and Earths

There is no doubt in my mind that by far the most neglected portions of our wireless receiving gear are the aerial and the earth. One erects an aerial wire suspended between the eaves of the house and a mast and just leaves it to look after itself as year follows year. One digs a hole in a flower bed and buries therein an earth connection, which may be the disused bath of the ex-baby. The baby grows to adolescence or even manhood and the bath is left *in situ*, on the principle that digging is hard

By "DIALLIST"

work, and, anyhow, the heart doesn't grieve over what the eye doesn't see.

But what happens to the aerial that is left swinging in the wind and the rain, and the sunshine and the frost, for years on end? Quite a few things. Its insulators, once highly efficient, become covered with a cement-like coating of dust and grime, which is not the best of insulating materials. If there is a soldered joint between the "roof" and the down lead this may suffer badly from the effects of corrosion. The lead-in itself is often of stranded wire with a rubber insulation. Examine yours, and see whether the rubber, once soft and pliable, has not become cracked, brittle and clearly almost useless as an insulator. And what about your aerial and earth terminals out of doors and the contacts of the earthing switch? Are they not covered with dirt and, possibly, with verdigris?

The Vital Earth

Nowadays the earth connection is of enormous importance. Almost any good modern set will pull in a fair number of home and foreign stations with the poorest of earths, or even with no earth at all. But it will bring them in none too well under such conditions, and you will probably find that noisiness is very obvious. Just what can happen to a perfectly good earth connection was brought home to me strikingly a year or two ago. Mine was then a 7 lb. biscuit tin, stripped of its original paper finery and buried in sound clay subsoil. After a longish time I began to find that I was not getting the results that I should have got from this set and that. I couldn't at first understand why such things should be, but eventually I was moved to delve down and examine that earth. Of the original noble tin nothing remained but traces of iron oxide in the soil and the wire rim, to which the strands of the lead-in wire were clinging precariously, making contact where they touched, which was not very often. That is a true story, and I won't labour the moral.

A good earth connection is of vital importance if you value performance, and it is no bad thing not to take yours too much for granted, but to dig down to it now and again to make certain that all is well. Don't forget, too, that deepening the hole in which it rests by even a few inches may sometimes work wonders. An earth surrounded by light, gravelly soil may make the poorest of contacts; but get down to the heavy subsoil—best of all to clay—and good contact is ensured.

Wales's New Station

PRELIMINARY work has already started on the North Wales relay station near Beaumaris. The station is expected to have an output rating of about 5 kilowatts and it is stated that it will be synchronised with the West Regional on 373.1 metres. Though this should much improve reception in North Wales the arrangement is not altogether ideal. The Beaumaris station will have to relay the West Regional programmes, which are already the cause of some heart burning. Dwellers in Devon and

Cornwall complain that the programmes are too Welsh in character and contain too many transmissions in the Welsh language for their liking. On the other hand, inhabitants of the Principality criticise the programmes as being far too English and not nearly Welsh enough. As in future the West Regional with its northern relay will serve almost the whole of Wales instead of just its more southerly parts, I don't envy its programme director his job.

A Calibration Service

Direct-reading Station Log

Mr. C. R. Hudson, of 89, Waverley Road, Southsea, Hants, has recently inaugurated a calibration service on novel and ingenious lines.

The Autolog system, as it is called, applies to receivers with dials marked 0-180 degrees or 0-100 divisions; enquirers are given a postcard on which to record the settings corresponding to five stations on each band. From this information curves are drawn on a specially printed card provided with a suitably engraved ivory cursor working on slides. The card is then returned to the enquirer, who can ascertain the tuning position of any station by setting the cursor and then reading the point of intersection with the appropriate medium- or long-wave curve.

AUTOLOG

BRITISH STATIONS: 250 to 550 Metres
LONG WAVES: 1,000 to 2,000 Metres
FOREIGN STATIONS: 400 to 550 Metres

Scale: 0 10 20 30 40 50 60 70 80 90 100 110 120 130 140 150 160 170 180

READING

BRITISH STATIONS: WEST REGIONAL, NORTH REGIONAL, SOUTH REGIONAL, LONDON NATIONAL, MIDLAND NATIONAL, NORTH NATIONAL, SOUTH NATIONAL, BRITISH NATIONAL, WEST NATIONAL, MIDLAND NATIONAL, NORTH NATIONAL, SOUTH NATIONAL.

FOREIGN STATIONS: BRUNNEN, GERMANY; RADIO PARIS, FRANCE; RADIO BRUXELLES, BELGIUM; RADIO VIENNA, AUSTRIA; RADIO BERLIN, GERMANY; RADIO MOSCOW, U.S.S.R.; RADIO LONDON, ENGLAND; RADIO PARIS, FRANCE; RADIO BRUXELLES, BELGIUM; RADIO VIENNA, AUSTRIA; RADIO BERLIN, GERMANY; RADIO MOSCOW, U.S.S.R.; RADIO LONDON, ENGLAND.

C. R. HUDSON, INSTRUMENT MAKER, 89, WAVERLEY ROAD, SOUTHSEA, HANTS.

Calibration costs 2s. 6d., or alternatively a complete outfit consisting of Autolog, flexible rule, pins and coloured pencils is supplied at the same price to those who prefer to calibrate their own sets.

PRINCIPAL BROADCASTING STATIONS OF EUROPE

Arranged in Order of Frequency and Wavelength

(This list is included in the first issue of each month. Stations with an aerial power of 50 kW. and above in heavy type)

Station.	kc/s.	Tuning Positions.	Metres.	kW.	Station.	kc/s.	Tuning Positions.	Metres.	kW.
Kaunas (Lithuania)	155		1935	7	Graz (Austria). (<i>Relays Vienna</i>)	886		338.6	7
Brazov (Romania)	160		1875	150	Helsinki (Finland)	895		335.2	10
Kootwijk (Holland) (<i>Relays Hilversum</i>)	160		1875	100	Hamburg (Germany)	904		331.9	100
Lahti (Finland)	166		1807	40	Limoges, P.T.T. (France)	913		328.6	120
Moscow, No. 1, RW1 (Komintern) (U.S.S.R.)	171.9		1745	500	Toulouse (Radio Toulouse) (France)	913		328.6	60
Paris (Radio Paris) (France)	182		1648	150	Brno (Czechoslovakia)	922		325.4	32
Istanbul (Turkey)	187.5		1600	5	Brussels, No. 2 (Belgium). (<i>Flemish Programme</i>)	932		321.9	15
Berlin (Deutschlandsender Zeesen) (Germany)	191		1571	150	Algiers, P.T.T. (Radio Alger) (Algeria)	941		318.8	12
Droitwich	200		1500	150	Göteborg (Sweden). (<i>Relays Stockholm</i>)	941		318.8	10
Minsk, RW10 (U.S.S.R.)	208		1442	35	Breslau (Germany)	950		315.8	100
Reykjavik (Iceland)	208		1442	16	Paris (Poste Parisien) (France)	959		312.8	60
Motala (Sweden). (<i>Relays Stockholm</i>)	216		1399	150	Belfast	977		307.1	1
Novosibirsk, RW76 (U.S.S.R.)	217.5		1379	100	Genoa (Italy). (<i>Relays Milan</i>)	986		304.3	10
Warsaw, No. 1 (Raszyn) (Poland)	224		1339	120	Hilversum (Holland). (15 kW. till 4.40 p.m.)	995		301.5	60
Ankara (Turkey)	230		1304	7	Bratislava (Czechoslovakia)	1004		298.8	13.5
Luxembourg	230		1304	150	Midland Regional (Droitwich)	1013		296.2	50
Kharkov, RW20 (U.S.S.R.)	232		1293	20	Barcelona, EAJ15 (Radio Asociación) (Spain)	1022		293.5	3
Kalundborg (Denmark)	238		1261	60	Cracow (Poland)	1022		293.5	2
Leningrad, RW53 (Kolpino) (U.S.S.R.)	245		1224	100	Heilsberg (Königsberg Ermland) (Germany)	1031		291	100
Tashkent, RW11 (U.S.S.R.)	256.4		1170	25	Paredo (Radio Club Português) (Portugal)	1031		291	5
Oslo (Norway)	260		1153.8	60	Leningrad, No. 2, RW70 (U.S.S.R.)	1040		288.5	10
Moscow, No. 2, RW49 (Stchekovo) (U.S.S.R.)	271		1107	100	Rennes, (Thourie) P.T.T. (France)	1040		288.5	120
Tiflis, RW7 (U.S.S.R.)	280		1071.4	35	Scottish National (Falkirk)	1050		285.7	50
Rostov-on-Don, RW12 (U.S.S.R.)	355		845	20	Bari (Italy)	1059		283.3	20
Budapest, No. 2 (Hungary)	359.5		834.5	20	Tiraspol, RW57 (U.S.S.R.)	1068		280.9	4
Sverdlovsk, RW5 (U.S.S.R.)	375		800	50	Bordeaux, P.T.T. (Lafayette) (France)	1077		278.6	120
Geneva (Switzerland). (<i>Relays Sottens</i>)	401		748	1.3	Zagreb (Yugoslavia)	1086		276.2	0.7
Moscow, No. 3 (RCZ) (U.S.S.R.)	401		748	100	Falun (Sweden)	1086		276.2	2
Voroneje, RW25 (U.S.S.R.)	413.5		726	10	Madrid, EAJ7 (Union Radio) (Spain)	1095		274	7
Oulu (Finland)	431		696	1.2	Madona (Latvia)	1104		271.7	50
Ufa, RW22 (U.S.S.R.)	436		688	10	Naples (Italy). (<i>Relays Rome</i>)	1104		271.7	1.5
Hamar (Norway). (<i>Relays Oslo</i>)	519		578	0.7	Moravska-Ostrava (Czechoslovakia)	1113		269.5	11.2
Innsbruck (Austria). (<i>Relays Vienna</i>)	519		578	1	Fécamp (Radio Normandie) (France)	1113		269.5	10
Ljubljana (Yugoslavia)	527		569.3	5	Alexandria (Egypt)	1122		267.4	0.25
Viipuri (Finland)	527		569.3	10	Newcastle	1122		267.4	1
Bolzano (Italy)	536		559.7	1	Nyiregyhaza (Hungary)	1122		267.4	6.2
Wilno (Poland)	536		559.7	18	Hörby (Sweden). (<i>Relays Stockholm</i>)	1131		265.3	10
Budapest, No. 1 (Hungary)	546		549.5	120	Turin, No. 1 (Italy). (<i>Relays Milan</i>)	1140		263.2	7
Beromünster (Switzerland)	556		539.6	100	London National (Brookmans Park)	1149		261.1	20
Athlone (Irish Free State)	565		531	60	North National (Slaithwaite)	1149		261.1	20
Palermo (Italy)	565		531	4	West National (Washford Cross)	1149		261.1	20
Stuttgart (Mühlacker) (Germany)	574		522.6	100	Kosice (Czechoslovakia). (<i>Relays Prague</i>)	1158		259.1	2.6
Grenoble, P.T.T. (France)	583		514.6	15	Monte Ceneri (Switzerland)	1167		257.1	15
Riga (Latvia)	583		514.6	15	Copenhagen (Denmark). (<i>Relays Kalundborg</i>)	1176		255.1	10
Vienna (Bisamberg) (Austria)	592		506.8	100	Kharkov, No. 2, RW4 (U.S.S.R.)	1185		253.2	10
Rabat (Radio Maroc) (Morocco)	601		499.2	25	Frankfurt (Germany)	1195		251	25
Sundsvall (Sweden). (<i>Relays Stockholm</i>)	601		499.2	10	Nice (La Brague) (France)	1185		253.2	60
Florence (Italy). (<i>Relays Milan</i>)	610		491.8	20	Prague, No. 2 (Czechoslovakia)	1204		249.2	5
Cairo (Abu Zabal) (Egypt)	620		483.9	20	Lille, P.T.T. (France)	1213		247.3	60
Brussels, No. 1 (Belgium). (<i>French Programme</i>)	620		483.9	15	Trieste (Italy)	1222		245.5	10
Lisbon (Bacarena) (Portugal)	629		476.9	20	Gleitwitz (Germany). (<i>Relays Breslau</i>)	1231		243.7	5
Trøndelag (Norway)	629		476.9	20	Cork (Irish Free State). (<i>Relays Athlone</i>)	1240		241.9	1
Prague, No. 1 (Czechoslovakia)	638		470.2	120	Juan-les-Pins (Radio Côte d'Azur) (France)	1249		240.2	2
Lyons, P.T.T. (La Doua Tramoyes) (France)	648		463	100	Kuldiga (Latvia)	1258		238.5	10
Cologne (Langenberg) (Germany)	658		455.9	100	Rome, No. 3 (Italy)	1258		238.5	1
North Regional (Slaithwaite)	668		449.1	50	San Sebastian (Spain)	1258		238.5	1
Sottens (Radio Suisse Romande) (Switzerland)	677		443.1	25	Nürnberg and Augsburg (Germany). (<i>Relays Munich</i>)	1267		236.8	2
Belgrade (Yugoslavia)	686		437.3	2.5	Christiansand and Stavanger (Norway)	1276		235.1	0.5
Paris, P.T.T. (Palaiseau Villebon) (France)	695		431.7	120	Dresden (Germany). (<i>Relays Leipzig</i>)	1285		233.5	0.25
Stockholm (Sweden)	704		426.1	55	Aberdeen	1285		233.5	1
Rome, No. 1 (Italy)	713		420.8	50	Austrian Relay Stations	1294		231.8	0.5
Kiev, RW9 (U.S.S.R.)	722		415.5	36	Danzig. (<i>Relays Königsberg</i>)	1303		230.2	0.5
Tallinn (Esthonia)	731		410.4	20	Swedish Relay Stations	1312		228.7	1.25
Madrid, EAJ2 (Radio España) (Spain)	731		410.4	3	Magyarovar (Hungary)	1321		227.1	1.25
Munich (Germany)	740		405.4	100	German Relay Stations	1330		225.6	1.5
Marseilles, P.T.T. (Realtor) (France)	749		400.5	90	Montpellier, P.T.T. (France)	1339		224	5
Katowice (Poland)	758		395.8	12	Lodz (Poland)	1339		224	1.7
Scottish Regional (Falkirk)	767		391.1	50	Dublin (Irish Free State). (<i>Relays Athlone</i>)	1348		222.6	0.5
Toulouse, P.T.T. (Muret) (France)	776		386.6	120	Milan, No. 2 (Italy). (<i>Relays Rome</i>)	1348		222.6	4
Leipzig (Germany)	785		382.2	120	Turin, No. 2 (Italy). (<i>Relays Rome</i>)	1357		221.1	0.2
Barcelona, EAJ1 (Spain)	795		377.4	7.5	Basle and Berne (Switzerland)	1375		218.2	0.5
Lwow (Poland)	795		377.4	16	Warsaw, No. 2 (Poland)	1384		216.8	2
West Regional (Washford Cross)	804		373.1	50	Lyons (Radio Lyons) (France)	1393		215.4	5
Milan (Italy)	814		368.6	50	Tampere (Finland)	1420		211.3	0.7
Bucharest (Romania)	823		364.5	12	Paris (Radio LL) (France)	1424		210.7	0.8
Moscow, No. 4, RW39 (Stalina) (U.S.S.R.)	832		360.6	100	Béziers (France)	1429		209.9	1.5
Berlin (Funkstunde Tegel) (Germany)	841		356.7	100	Miskolc (Hungary)	1438		208.6	1.25
Bergen (Norway)	850		352.9	1	Paris (Eiffel Tower) (France)	1456		206	5
Sofia (Bulgaria)	850		352.9	50	Pecs (Hungary)	1465		204.8	1.25
Valencia (Spain)	850		352.9	3	Bournemouth	1474		203.5	1
Simferopol, RW52 (U.S.S.R.)	859		349.2	10	Plymouth	1474		203.5	0.3
Strasbourg, P.T.T. (France)	859		349.2	100	International Common Wave	1492		201.1	0.2
Poznan (Poland)	868		345.6	16	International Common Wave	1500		200	0.25
London Regional (Brookmans Park)	877		342.1	50	Liepāja (Latvia)	1737		173	0.1

NOTE.—Since the publication of the previous list alterations have been made to the following stations: Moscow (U.S.S.R.), Paris (France), Berlin (Germany), Paris, P.T.T. (France), Marseilles, P.T.T. (France), Toulouse, P.T.T. (France), Barcelona (Spain), Sofia (Bulgaria), Strasbourg (France), Limoges (France), Hilversum (Holland), Rennes, P.T.T. (France), Bordeaux (France), Nice (France).

SHORT-WAVE STATIONS OF THE WORLD

Arranged in Order of Wavelength and Frequency

(N.B.—Times of Transmission given in parentheses are approximate only and represent G.M.T.)

Metres.	kc/s.	Call Sign.	Station.	Tuning Positions.	Metres.	kc/s.	Call Sign.	Station.	Tuning Positions.
84.67	3,543	CR7AA	Mozambique (E. Africa). (Mon., Thurs., Sat., 18.30 to 20.30.)		37.33	8,035	CNR	Rabat (Morocco). (Sun. 20.00 to 22.30)...	
75.0	4,000	CT2AJ	Ponta Delgada (Azores). (Wed., Sat., 22.00 to 24.00.)		36.5	8,214	HCB	Quito (Ecuador). (Daily ex. Sun., Mon. 00.45 to 04.15, Sun. 21.45 to 04.15.)	
70.2	4,273	RV15	Kharbarovsk (U.S.S.R.). (Daily 06.00 to 14.00.)		34.20	8,750	ZCK	Hong Kong (China). (Daily 10.00 to 14.00.)	
67.11	4,470	YDB	Sourabaya (Java). (Daily 03.30 to 06.30)		32.88	9,134	HAT4	Budapest (Hungary). (Sat. 23.00 to 24.00)	
58.31	5,145	OK1MPT	Prague (Czechoslovakia). (Experimental)		31.8	9,428	COH	Havana (Cuba). (Daily 16.00 to 17.00, 22.00 to 23.00, 01.00 to 02.00.)	
51.28	5,850	YV5RMO	Maracaibo (Venezuela). (Daily, 22.00 to 02.00.)		31.56	9,500	PRF5	Rio de Janeiro (Brazil). (Daily 22.30 to 23.15.)	
50.42	5,950	HJ4ABE	Medellin (Colombia). (Daily, 16.30 to 18.30, Sun., Tues., Thurs., 23.30 to 03.00 also.)		31.55	9,510	GSB	Empire Broadcasting	
50.26	5,969	HVJ	Vatican City. (Daily 19.00 to 19.15, Sun. 10.00 also.)		31.54	9,518	VK3ME	Melbourne (Australia). (Wed. 10.00 to 11.30, Sat. 10.00 to 12.00.)	
50.16	5,980	HIX	Santa Domingo (W. Indies). (Daily, 12.00 Sun. 00.38 also.)		31.48	9,530	LKJ1	Jeløy (Norway). (Relays Oslo.) (Daily 10.00 to 13.00.)	
50.0	6,000	RW59	Moscow (U.S.S.R.). (Relays No. 1 Stn.) (Daily 20.00 to 23.00.)		31.48	9,530	W2XAF	Schenectady, N.Y. (U.S.A.). (Relays WGF.) (Daily 23.30 to 04.00, Sat. 19.00 to 22.00 also.)	
49.96	6,005	VE9DN	Montreal (Canada). (Daily 04.30 to 05.00)		31.45	9,540	DJN	Zeesen (Germany). (Daily 08.45 to 12.15, 13.00 to 16.30, 22.15 to 03.30.)	
49.96	6,005	HJ3ABH	Bogotá (Colombia)		31.38	9,560	DJA	Zeesen (Germany). (Daily 13.00 to 16.30, 22.15 to 02.00.)	
49.92	6,010	COC	Havana (Cuba). (Daily 21.00 to 23.00, 01.00 to 03.00, Sun. 04.30 to 06.30 also.)		31.36	9,565	VUB	Bombay (India). (Sun. 13.30 to 15.30, Wed., Thurs., Sat. 16.30 to 17.30, irregular Mon.)	
49.85	6,018	ZHI	Singapore (Malaya). (Mon., Wed., Thurs. 23.00 to 01.30, Sun. 03.40 to 05.10.)		31.35	9,570	W1XK	Springfield, Mass. (U.S.A.). (Relays WBZ.) (Daily 12.00 to 06.00.)	
49.83	6,020	DJC	Zeesen (Germany). (Daily 22.30 to 03.30, 17.00 to 21.30.)		31.32	9,580	GSC	Empire Broadcasting	
49.75	6,030	HP5B	Panama City (Central America). (Daily 17.00 to 18.00, 01.00 to 03.30.)		31.32	9,580	VK3LR	Lindhurst (Australia). (Daily ex. Sun. 08.15 to 12.30.)	
49.75	6,030	VE9CA	Calgary (Canada). (Thurs. 14.00 to 07.00, Sun. 17.00 to 05.00.)		31.28	9,590	W3XAU	Philadelphia, Pa. (U.S.A.). (Relays WCAU.) (Daily 17.00 to 24.00.)	
49.67	6,040	W1XAL	Boston, Mass. (U.S.A.). (Sun. 22.00 to 24.00, Wed., Fri. 00.30 to 01.45.)		31.28	9,590	VK2ME	Sydney (Australia). (Sun. 06.00 to 08.00, 10.00 to 14.00, 14.30 to 16.30.)	
49.67	6,040	PRA8	Pernambuco (Brazil). (Daily 20.00 to 00.30.)		31.27	9,595	HBL	Radio Nations, Prangins (Switzerland). (Sat. 22.30 to 23.15.)	
49.59	6,050	GSA	Empire Broadcasting		31.25	9,598	CT1AA	Lisbon (Portugal)	
49.5	6,060	W8XAL	Cincinnati, Ohio (U.S.A.). (Daily 12.00 to 01.00, 04.00 to 06.00.)		31.13	9,637	2RO	Rome (Italy). (Tues., Thurs., Sat. 00.45 to 02.15.)	
49.5	6,060	W3XAU	Philadelphia, Pa. (U.S.A.). (Relays WCAU.) (Daily 01.00 to 04.00.)		31.0	9,677	CT1CT	Lisbon (Portugal). (Thurs. 21.00 to 23.00, Sun. 12.00 to 14.00.)	
49.5	6,060	OXY	Skamlebaek (Denmark). (Relays Kalundborg.) (Daily 18.00 to 24.00, Sun. 16.00 also.)		30.43	9,860	EAQ	Madrid (Spain). (Daily 22.15 to 00.30, Sat. 18.00 to 20.00 also.)	
49.42	6,070	OER2	Vienna Experimental. (Daily 14.00 to 22.00.)		29.04	10,330	ORK	Ruyssenele (Belgium). (Daily 18.30 to 20.30.)	
49.4	6,072	CT1AA	Lisbon (Portugal). (Tues., Thurs., Sat. 21.30 to 24.00.)		27.93	10,740	JVM	Tokio (Japan). (Tues., Fri. 19.00 to 20.00.)	
49.33	6,080	W9XAA	Chicago, Ill. (U.S.A.). (Relays WCLF.) (Sun. 19.00 to 20.30.)		25.65	11,695	YB3RC	Caracas (Venezuela)	
49.33	6,080	CP5	La Paz (Bolivia). (Daily 00.45 to 02.15)		25.6	11,720	FYA	Paris, Radio Coloniale (France). (Colonial Stn. E.W.) (Daily 00.00 to 03.00, 04.00 to 06.00.)	
49.3	6,085	2RO	Rome (Italy). (Mon., Wed., Fri. 23.00 to 00.30.)		25.6	11,720	CJRX	Winnipeg (Canada). (Daily 00.00 to 05.00, Sat. 21.00 to 06.00 also, Sun. 22.00 to 03.30 also.)	
49.26	6,090	VE9BJ	St. John (N.B.). (Daily 00.00 to 01.30)...		25.57	11,730	PH1	Eindhoven (Holland). (Daily ex. Tues., Wed. 13.00 to 15.30 (Sun., Sat. to 16.30.)	
49.26	6,090	VE9GW	Bowmanville, Ont. (Canada). (Mon., Tues., Wed. 20.00 to 05.00, Thurs., Fri., Sat. 12.00 to 05.00, Sun. 18.00 to 02.00.)		25.53	11,750	GSD	Empire Broadcasting	
49.2	6,097	ZTJ	Johannesburg (S. Africa). (Daily ex. Sun. 04.30 to 05.30, 08.30 to 12.00, 14.00 to 20.00 (Sat. to 21.45), Sun. 13.00 to 15.15, 17.30 to 20.00.)		25.49	11,770	DJD	Zeesen (Germany). (Daily 17.00 to 21.30)	
49.18	6,100	W8XAL	Bound Brook, N.Y. (U.S.A.). (Relays WJZ.) (Mon., Wed., Sat. 22.00 to 23.00, Sat. 05.00 to 06.00 also.)		25.45	11,790	W1XAL	Boston, Mass. (U.S.A.). (Daily 23.00 to 00.30.)	
49.18	6,100	W9XF	Chicago, Ill. (U.S.A.). (Daily ex. Mon., Wed., Sun. 21.00 to 07.00.)		25.40	11,811	2RO	Rome (Italy). (Mon., Wed., Fri. 23.00)...	
49.1	6,110	VUC	Calcutta (India). (Daily 07.06 to 08.06 irregular 13.06 to 16.36, Sat. from 12.36, Sun. 04.36 to 07.36, irregular 12.36 to 03.36.)		25.36	11,830	W2XE	Wayne, N.J. (U.S.A.). (Relays WABC.) (Daily 20.00 to 22.00.)	
49.1	6,110	GSL	Empire Broadcasting		25.29	11,860	GSE	Empire Broadcasting	
49.08	6,112	YV2RC	Caracas (Venezuela). (Daily ex. Sun. 15.30 to 17.30, 21.00 to 03.00, Sun. 14.30 to 15.30.)		25.27	11,870	W8XK	Pittsburg, Pa. (U.S.A.). (Relays KDKA.) (Daily 21.30 to 03.00.)	
49.02	6,120	VQ7LO	Nairobi (Kenya Colony). (Daily 16.00 to 19.00, Sat. to 20.00, Mon., Wed., Fri. 10.45 to 11.15 also, Tues. 08.00 to 09.00 also, Thurs. 13.00 to 14.00 also, Sun. 17.45 to 19.00 also.)		25.23	11,880	FYA	Paris, Radio Coloniale (France). (Colonial Stn. N.S.) (Daily 16.15 to 19.15, 20.00 to 23.00.)	
49.02	6,120	YDA	Bandoeng (Java). (Daily 10.30 to 15.00)		25.0	12,000	RW59	Moscow (U.S.S.R.). (Relays No. 2 Stn.) (Sun. 03.00 to 04.00, 11.00 to 12.00, 15.00 to 16.00.)	
49.02	6,120	W2XE	Wayne, N.J. (U.S.A.). (Relays WABC.) (Daily 23.00 to 04.00.)		24.83	12,082	CT1CT	Lisbon (Portugal). (Sun. 14.00 to 16.00, Thurs. 20.00 to 21.00.)	
48.92	6,132	ZGE	Kuala Lumpur (Malaya). (Sun., Tues., Fri. 11.40 to 13.40.)		24.2	12,396	CT1GO	Paredo (Portugal). (Sun. 15.00 to 16.30, Tues., Thurs., Fri. 18.00 to 19.15.)	
48.86	6,140	W8XK	Pittsburg, Pa. (U.S.A.). (Relays KDKA.) (Daily 21.30 to 06.00.)		23.39	12,830	CNR	Rabat (Morocco).	
48.78	6,150	CSL	Lisbon (Portugal). (Daily 11.00 to 12.30, 18.00 to 22.00.)		22.94	13,075	VPD	Suva (Fiji). (Daily ex. Sun. 05.30 to 03.60)	
48.78	6,150	YV3RC	Caracas (Venezuela). (Daily 20.30 to 01.30.)		19.84	15,123	HVJ	Vatican City. (Daily 10.00, 15.30 to 15.45)	
48.78	6,150	CJRO	Winnipeg (Canada). (Daily 00.00 to 05.00, Sat. 21.00 to 06.00 also, Sun. 22.00 to 03.30.)		19.82	15,140	GSF	Empire Broadcasting	
48.4	6,198	CT1GO	Paredo (Portugal). (Daily ex. Tues. 00.20 to 01.30, Sun. 16.30 to 18.00 also.)		19.74	15,200	DJB	Zeesen (Germany). (Daily 08.45 to 12.15)	
47.50	6,316	HIZ	Santo Domingo (W. Indies). (Daily 21.40 to 22.40, Sun. 16.00 to 17.30 also.)		19.72	15,210	W8XK	Pittsburg, Pa. (U.S.A.). (Relays KDKA.) (Daily 13.00 to 21.15.)	
47.05	6,375	YV4RC	Caracas (Venezuela). (Daily 21.30 to 03.30.)		19.71	15,220	PCJ	Eindhoven (Holland). (Experimental) ...	
46.89	6,425	W3XL	Bound Brook, N.J. (U.S.A.). (Experimental)		19.68	15,243	FYA	Paris, Radio Coloniale (France). (Colonial Stn. E.W.) (Daily 12.00 to 16.00.)	
46.52	6,447	HJ1ABB	Barranquilla (Colombia). (Daily 21.30 to 03.30.)		19.67	15,250	W1XAL	Boston, Mass. (U.S.A.). (Daily 15.50 to 18.30.)	
46.21	6,490	HJ5ABD	Cali (Colombia). (Daily 00.00 to 03.00)...		19.66	15,260	GS1	Empire Broadcasting	
46.0	6,520	YV6RV	Valencia (Venezuela). (Daily 17.00 to 18.00, 23.00 to 03.00.)		19.64	15,270	W2XE	Wayne, N.J. (U.S.A.). (Relays WABC.) (Daily 16.00 to 18.00.)	
45.31	6,620	PRADO	Riobamba (Ecuador). (Fri. 02.00 to 03.40)		19.63	15,280	DJQ	Zeesen (Germany). (Daily 04.30 to 06.00)	
45.0	6,667	HC2RL	Guayaquil (Ecuador). (Sun. 22.45 to 12.45, Wed. 02.15 to 04.15.)		19.6	15,300	CP7	La Paz (Bolivia)	
42.02	7,140	AJ4ABB	Manizales (Colombia)		19.56	15,330	W2XAD	Schenectady, N.Y. (U.S.A.). (Daily 19.30 to 20.30.)	
41.8	7,177	CR6AA	Lobito (Angola). (Wed., Sat. 19.30 to 21.30.)		19.52	15,370	HAS3	Budapest (Hungary). (Sun. 13.00 to 14.00.)	
38.48	7,797	HBP	Radio Nations, Prangins (Switzerland). (Sat. 22.30 to 23.15.)		16.89	17,760	DJE	Zeesen (Germany). (Daily 13.00 to 16.30)	
					16.88	17,770	PHI	Huizen (Holland). (Daily ex. Tues., Wed. 13.30 to 15.30, Sun. 15.30 to 16.10, Sat. 15.30 to 16.30 also.)	
					16.87	17,780	W3XAL	Bound Brook, N.J. (U.S.A.). (Relays WJZ.) (Daily except Sun. 14.00 to 15.00, Tues. Thurs., Fri. 20.00 to 21.00 also.)	
					16.86	17,790	GSQ	Empire Broadcasting	
					15.95	18,830	PLE	Bandoeng (Java). (Tues., Thurs., Sat. 15.00 to 15.30.)	
					13.97	21,470	GSH	Empire Broadcasting	
					13.93	21,530	GSJ	Empire Broadcasting	
					13.92	21,540	W8XK	Pittsburg, Pa. (U.S.A.). (Daily 12.00 to 14.00.)	

The Wireless World

THE
PRACTICAL RADIO
JOURNAL
25th Year of Publication

No. 841.

FRIDAY, OCTOBER 11TH, 1935.

VOL. XXXVII.

No. 15.

Proprietors: ILIFFE & SONS LTD.

Editor:
HUGH S. POCOCK.

Editorial,
Advertising and Publishing Offices:
DORSET HOUSE, STAMFORD STREET,
LONDON, S.E.1.

Telephone: Hop 3333 (50 lines).
Telegrams: "Ethaworld, Sedist, London."

COVENTRY: Hertford Street.

Telegrams: "Autocar, Coventry."
Telephone: 5210 Coventry.

BIRMINGHAM:

Guildhall Buildings, Navigation Street, 2.
Telegrams: "Autopress, Birmingham."
Telephone: 2971 Midland (4 lines).

MANCHESTER: 260, Deansgate, 3.

Telegrams: "Iliffe, Manchester."
Telephone: Blackfriars 4412 (4 lines).

GLASGOW: 26B, Renfield Street, C.2.

Telegrams: "Iliffe, Glasgow." Telephone: Central 4857.

PUBLISHED WEEKLY. ENTERED AS SECOND
CLASS MATTER AT NEW YORK, N.Y.

Subscription Rates:

Home, £1 1s. 8d.; Canada, £1 1s. 8d.; other
countries, £1 3s. 10d. per annum.

*As many of the circuits and apparatus described in these
pages are covered by patents, readers are advised, before
making use of them, to satisfy themselves that they would
not be infringing patents.*

CONTENTS

	Page
Editorial Comment	387
France Wakes Up	388
Loud-Speaker Volume Controls..	391
Super Regeneration on the Ultra- Short-Waves	393
Current Topics	395
The Development of the Wireless Aerial—III	396
Hints and Tips	399
Listeners' Guide for the Week ..	400
Deaf Aids—II	402
Variable Selectivity	405
Broadcast Brevities	407
Unbiased	408
Wayfarer Portable Reviewed ..	409

EDITORIAL COMMENT

Second-hand Sets

Our Proposal Welcomed

ALREADY there are indications that the idea of making *The Wireless World* the recognised medium for the purchase or sale of second-hand sets has met with general approval.

The radio industry sees in it a solution of the present difficulty that sets tend to "stagnate" after purchase because the owners have no means of passing them on to make way for new purchases.

The general public will find *The Wireless World* a medium for real bargains in efficient second-hand sets—such bargains as will surprise many of our readers, too.

Those whose interest in wireless is more serious and technical will find bargains, even in second-hand sets too out of date to be used as they are, because they will be able to remodel them or use the set as a "mine" from which to extract useful component parts as they may be required for other purposes.

Prices Will Stabilise

At first it will no doubt be found that prices asked by different owners for sets of the same date will vary widely. This is only to be expected until second-hand set prices begin to find their proper level. This difficulty must be expected at the outset so that readers should not be disappointed if they find their advertisement brings no result if the reason is that their price is above the average.

This week we repeat in our advertisement pages the coupon entitling any reader to a free advertisement to enable him to offer his present or spare receiver for sale. We hope that good

use will be made of these coupons in order to ensure that the scheme meets with success at the outset.

Readers will be doing a good service to their friends if they will point out to them that this feature begins in *The Wireless World* of October 18th, and that it promises to contain real bargains which will interest them.

Television

Need for Demonstrations

BOTH the Baird Company and Marconi-E.M.I. are at present busy with the construction of television transmitters which the B.B.C. have ordered for erection at the Alexandra Palace. When these stations are "on the air" sometime next spring there will be a demand for sets to enable the public to receive the transmissions. How great the demand will be it is difficult to conjecture, so much will depend upon the publicity which television receives at that time and on how ready the public will be to spend rather a large sum on a receiver before they have any real assurance as to what entertainment will be provided for them by way of programmes.

We hope that arrangements will be made in good time so that when the transmissions start the public will be able to attend demonstrations in all parts of the service area of the station without difficulty. For this purpose it will be very desirable to arrange for a number of receivers to be set up by local radio dealers, in large stores and elsewhere, whilst the B.B.C. could probably also arrange facilities, for public demonstrations. All this should be done in time for the commencement of the transmissions and not left to be thought about after they are under way.

France Wakes Up — HOW THE AFFECTS

ALREADY the new French Regional stations are landmarks in the European ether. Developments within the next few months will give British listeners a wealth of fresh programme material.

HOW many listeners are taking note of the fact that a French Revolution is in progress—a revolution which not only sweeps France for the first time into the main arena of European broadcasting, but promises to alter the balance of programme material available to listeners in Spain, Italy, Switzerland, Belgium, Holland and Britain?

The coming winter will prove that the opening of the new French Regional scheme is quite the most interesting feature of European radio at the present time.

French broadcasting, battling for years against a gangrene of delay, official circumlocution, private interest and public apathy, has been the bread-and-butter of every radio humorist. France has seen Germany, still staggering from the effects of the Great War, build up a powerful radio organisation perfectly adapted for propaganda as well as for the entertainment of the masses; yet her own broadcasting "system," if such it can be called, has consisted of a number of ineffectual Post Office stations wielding less influence than the dozen or more clamorous private transmitters. Of the latter, the authorities might remark as did Mark Twain of *pulices irritantes* in the hotel bed: "If they had been unanimous they would have had me out."

Paradoxically, France possessed the first real broadcasting station in Europe, viz., the Eiffel Tower, which was sending out time signals free, gratis and for nothing long before the war.

It was only four years ago, however, that France really bestirred herself to the extent of discussing a possible Regional scheme with the primary object of ensuring reliable reception for all sections of

port of that Eiffel Tower veteran, General Gustave Ferrié, who devised a plan which, in all essential aspects, is the one which is being proceeded with to-day. The famous Plan passed through many vicissitudes. One Government after another, intending to put it into effect, was thrown out, and it is only within the last two years that a measure of political stability has enabled General Ferrié's carefully

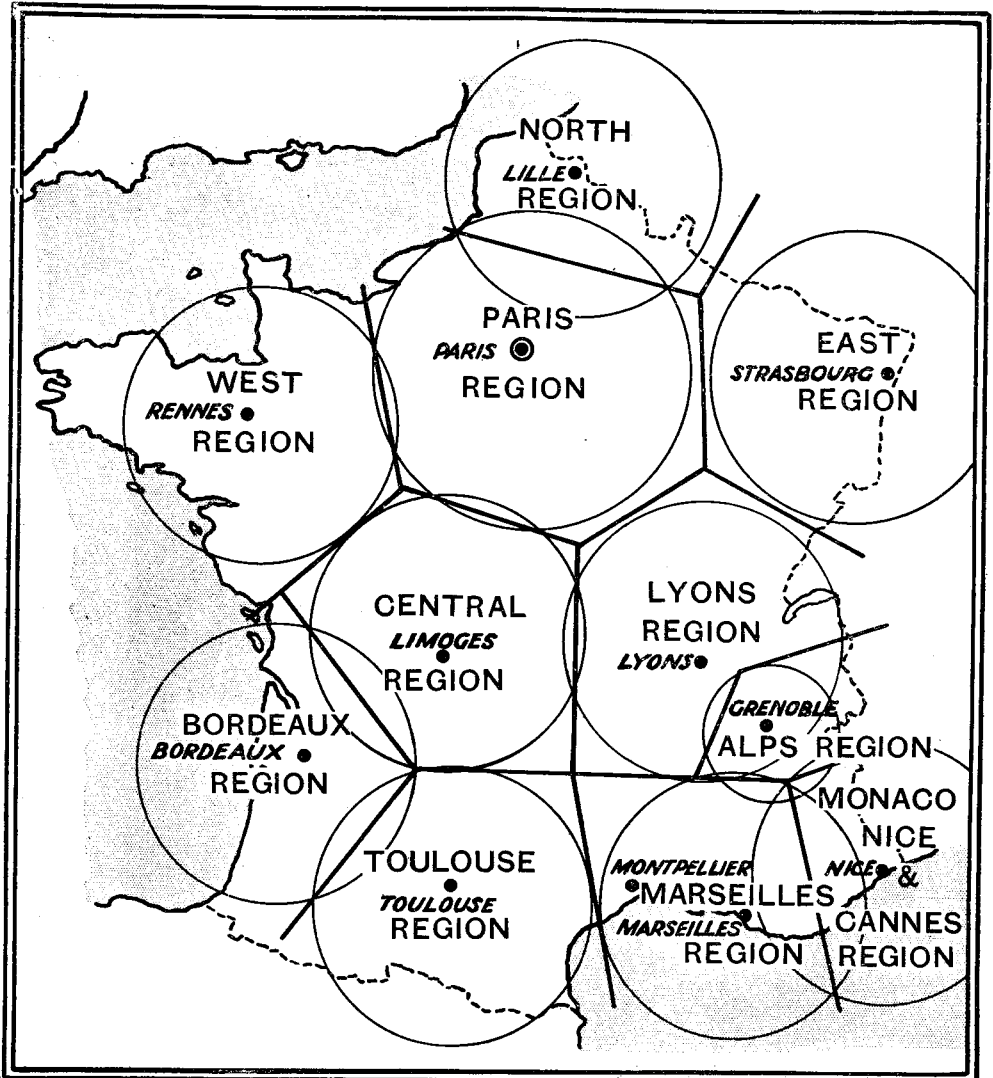

(Above) Differing little from the late General Ferrié's plan of 1932, the French Regional scheme is designed to cover practically the whole country.

(Left) The "listening station" at Coigniers is the French equivalent of Tatsfield.

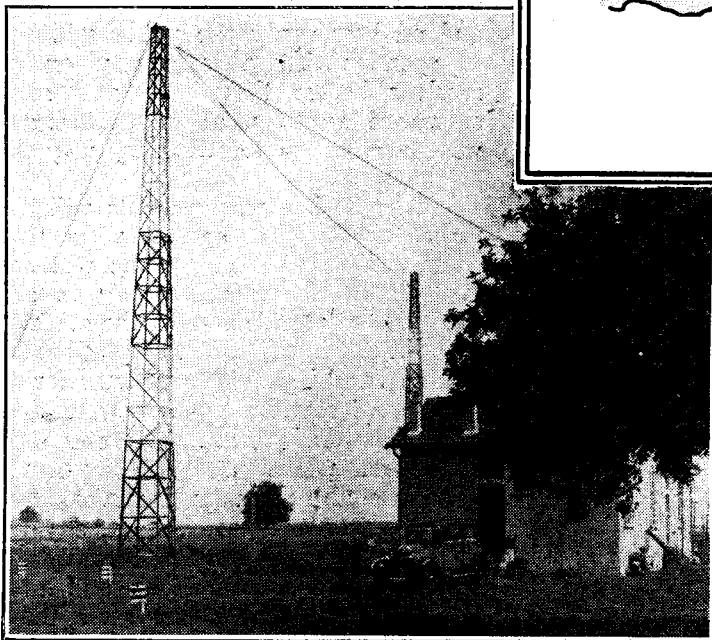

the public, irrespective of their purchasing power in relation to goods advertised at the microphone. The wise step was taken of enlisting the sup-

ported out scheme to take practical shape. Much of the credit must go to M. Mandel, the present French Postmaster-General, who was recently described by a *Wireless World* correspondent as a "Mr. Hore-Belisha of the air."

With juggler's skill M. Mandel has kept a dozen oranges in the air at once, unifying the interests of the trade, the powerful amateur associations, the musical and literary organisations, the politicians, the technical pundits, and all those other entities which have to be placated

REGIONAL SCHEME BRITISH LISTENERS

By
E. C. THOMSON

before any headway can be made in so delicate and novel a project as modern broadcasting.

Altogether there are in the French scheme ten high-power stations, ranging in output from 60 to 150 kilowatts, so distributed throughout the country that practically all parts are within the service area of one or more transmitters. These regions correspond to the "electoral divisions" decreed by M. Mandel for the recent ballots by which listeners are able to send their own representatives to the broadcasting councils of the respective districts.

Five Stations Working

At the present moment five of the stations are actually operating, viz., Lille-Camphin (60 kilowatts, 247.3 metres); Palaiseau Villebon, Paris (120 kilowatts, 431.7 metres); Lyons-Tramoyes (100 kilowatts, 463 metres); Strasbourg (100 kilowatts, 349.2 metres) and Toulouse Muret (120 kilowatts, 388.6 metres), and two others are to begin testing almost at once. These are Nice, La

meant anything or nothing, but to-day can be taken at its face value. These are: Bordeaux Lafayette (120 kilowatts, 278.6 metres); Limoges (120 kilowatts, 328.6 metres); and the new Radio-Paris (150 kilowatts, 1,648 metres).

The new PTT station at Villebon is typical of the French Regional stations. It is situated about 12½ miles from the centre of Paris on a high plateau dominating

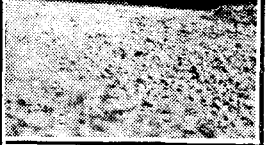
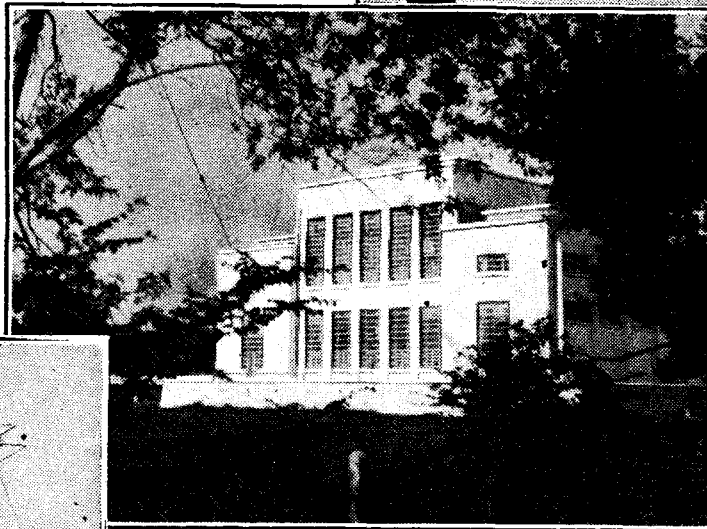

(Photo: F. Detaille.)

Marseilles, Réaltor, is due to begin tests almost at once on 400.5 metres with a power of 90 kilowatts.

the Commune of Villebon-sur-Yvette. Here a large tract of ground has been secured by the authorities not only for the home trans-

mitter but for two high-power short-wave transmitters for the Colonial service. At present two buildings of reinforced concrete stand on the site, one containing the power plant for the exist-

A picturesque glimpse of the Nice transmitter hall.

A general view of the new "radio city"—Nice.

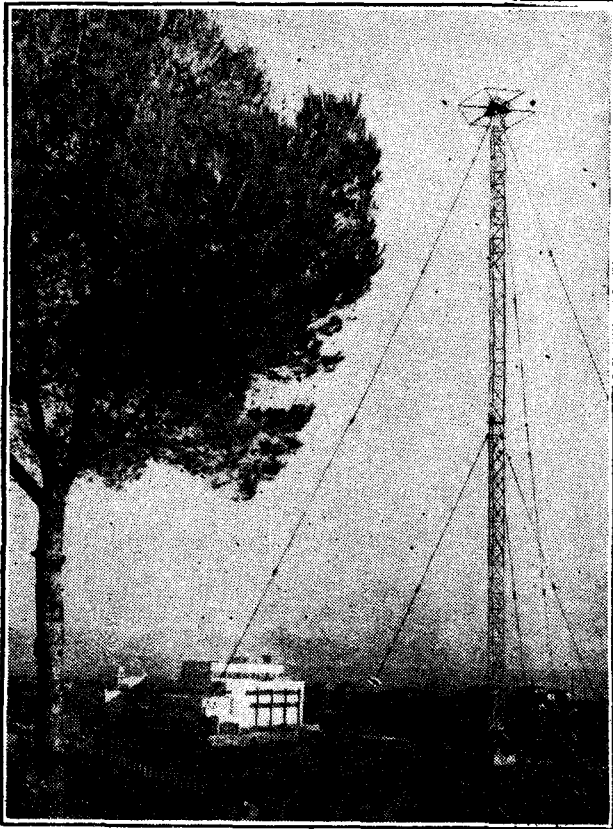

Nice, La Brague, a 60-kW. transmitter which is about to begin testing on 253.2 metres.

Brague (60 kilowatts, 253.2 metres) and Marseilles, Réaltor (90 kilowatts, 400.5 metres). Before Christmas the Rennes-Thourie station (120 kilowatts, 288.6 metres) will also be in service.

Three stations are "projected"—a term which a few years ago might have



France Wakes Up—

ing Paris Regional (PTT), and for the projected Colonial Station, and the other new PTT transmitter and power installation.

The new station is arranged in two storeys. The machine room occupies the ground floor together with six mercury arc rectifiers, of which four are used with an output of 240 kilowatts when the station is working under normal conditions. All apparatus is duplicated to avoid lengthy interruptions, the movement of a lever replacing any defective part almost at once.



Photos : Pasquers and Dupuis, Lille.

"Broadcasting House," Lille, and the new North Region transmitter, already working on 247.3 metres. The power is 60 kilowatts.

it is understood that 120 kilowatts is about to be used. Listeners everywhere are invited to send reports of reception from Palaisseau Villebon, or any of the other new transmitters, to the French Post Office, Rue de Grenelle, Paris.

Side by side with these technical developments in French broadcasting have gone distinct improvements in the programme material. Although gramophone records are still largely resorted to, the listener does not nowadays get the impression of cheeseparing economy which was the mark of all the French stations two or three years ago. The French

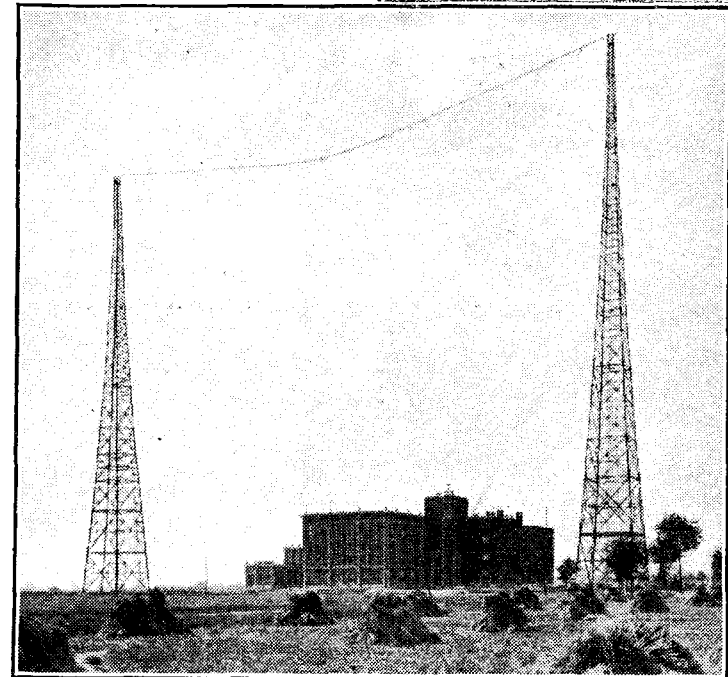

On the first floor is the actual transmitter, constructed by the Société Française Radioélectrique. It is controlled by a quartz oscillator within 1/500,000 of a cycle. Modulation is effected after the first amplification stage.

Water-cooled valves in the second amplifier stage operate on a high-tension voltage of 20,000. Frequency modulation is employed.

As in the case of Droitwich, Deutschlandsender and other big transmitters, the entire installation is under the control of a single engineer seated at the control desk.

The aerial is of the half-wave vertical type, supported by two masts some 500 feet high.

High-frequency cables connect the transmitter with the control room in the Rue des Archives, Paris, and it is interesting to note that this cable comprises four television circuits capable of handling frequencies up to 100,000 cycles a second.

The first tests at Villebon were made on August 15th, with a power of 30 kilowatts, which was speedily increased to 80 kilowatts. At the time of writing

National Orchestra is already accounted one of the best broadcasting orchestras of to-day, its "Dr. Boulton" being M. Inghelbrecht, who has long been a prominent figure in French musical circles.

A wideawake policy has been pursued in "O.B." work as witness the excellent day-to-day broadcasts of the recent *Tour de France*—a broadcast which must be regarded as unique. Its success was partly due to the new and improved system of landlines which now enmesh the entire country.

France may prove to us all during the long winter evenings that a slow starter, even in wireless matters, can claim definite advantages over its more impetuous rivals. At all events British listeners will have another four or five high-power transmissions from which to choose, and there is no extra charge.

The Empire Broadcast Service

Second Edition

A 39-page Booklet with Numerous Illustrations and Diagrams. Published by The British Broadcasting Corporation, Broadcasting House, London, W.1. Gratis.

AS its title implies, this publication deals exclusively with the Empire short-wave transmissions from Daventry. Following a brief but interesting description of the early experimental transmissions from 5SW, Chelmsford, comes a section devoted to the special programmes compiled for overseas listeners, and then an explanation is given for the abandonment of the original zone scheme and its replacement by a division of the programme time into six transmitting periods identified by numbers.

The technical section gives some interesting facts regarding the transmitters, a complete list of the wavelengths employed, and then devotes many pages to the all-important question of reception. Various types of receivers are discussed, and then follows some very helpful and practical advice on short-wave aerials and feeder systems.

The technical matter is presented in a manner that can be readily followed by non-technical readers, yet the experienced short-wave listener will find this section not devoid of useful data and sound practical advice.

Whilst this booklet is intended primarily for overseas listeners, it is also available to those about to proceed abroad and who are interested in the reception of the Empire short-wave programmes.

H. B. D.

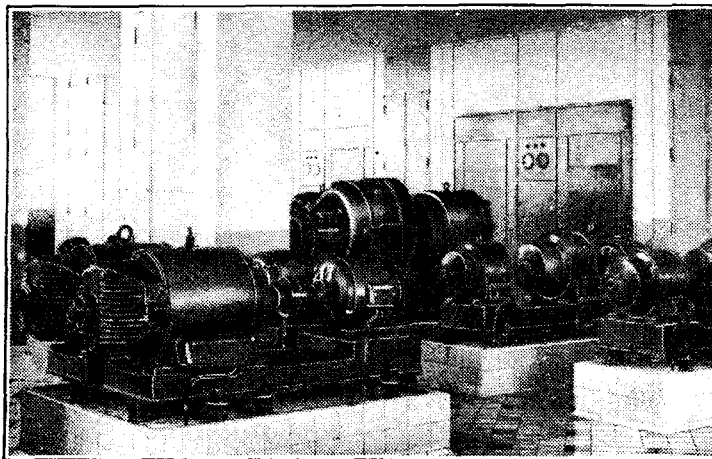

The machinery hall at the new Paris P.T.T. transmitter at Villebon.

Loud-Speaker Volume

Avoiding Distortion at Low Levels

Controls

By MAXWELL G. SMITH

IT is usually convenient to have means of directly controlling the volume of an extension loud speaker, but the usual methods are apt to introduce distortion. The writer of this article suggests a compensating arrangement whereby over-accentuation of the bass or treble at low volume levels may be avoided

THE necessity of having to adjust volume at the set obviously detracts from the advantages of the extension speaker, and where two or more extension points are provided it is really essential to be able to control the level "locally," as members of the household listening in different rooms will very possibly not all wish to hear the programme at the same volume.

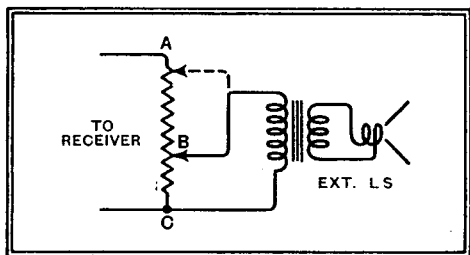

Fig. 1.—A volume-control potentiometer connected in this way causes high-note loss.

Unfortunately the results obtained by connecting a control in the obvious manner are certainly not all that could be desired, as it will be found that the quality is seriously affected as volume is reduced below a certain level. For the benefit of those who have not before had experience with this form of volume control the chief difficulties are outlined below.

Shortcomings of Ordinary Controls

The method of connecting a control which first presents itself is illustrated in Fig. 1. When the control is set for maximum volume (dotted line), the speaker is connected as normally in the output circuit; the only difference is that it is shunted by a resistance, the value of which must be so chosen that it has little effect on reproduction. This value is not critical. If the control is connected across the primary of the extension speaker transformer its value should be from 10,000 to 50,000 ohms. If connected across the secondary (a more suitable arrangement in many cases) about 150 ohms will suffice. When the control is set for reduced volume (say, only 25 per cent. of the maximum) the greater portion of the total power is dissipated in the section AB of the volume control, which section is in series with the speaker. It will be seen that the speaker is now shunted by the comparatively low resistance BC. Now,

BC offers a much lower impedance to the higher frequencies than the speaker, consequently at these frequencies more current will flow via BC than via the speaker, with the result that only a small proportion of the total high-frequency power available (after attenuation by AB) is developed in the speaker. The low frequencies, on the other hand, are not affected to any appreciable extent by BC, as the impedance of the speaker at these frequencies is much less, so that nearly all the LF power remaining after attenuation by AB is delivered to the speaker. The net result is a gradual falling off in volume with increasing frequency. The lowest frequencies flow *via* the speaker, the middle frequencies are divided more or less equally between the speaker and BC while the high frequencies flow *via* BC and are not reproduced. This is illustrated graphically in Fig. 2, curve B. This and the other curves are, of course, purely arbitrary.

Now as this high-note cut-off is due to the low resistance shunt BC, the circuit of Fig. 3 would at first sight appear to overcome this, as BC is now out of circuit.

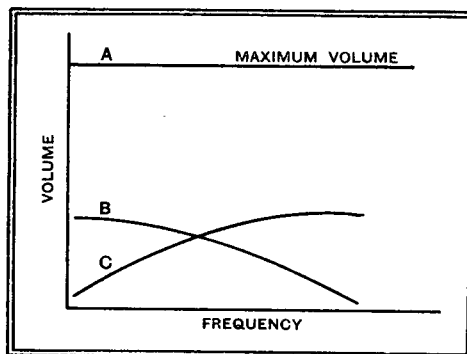

Fig. 2.—Curves showing the effects of two different types of volume control.

The effect now of reducing level is merely to insert the high resistance AB in series with the speaker. Now, being a series circuit, the same value of current must flow through all parts of the circuit at any given frequency. Therefore the power developed in each part depends upon its impedance. At high frequencies the greater part of the total impedance now in circuit is offered by the loud speaker, therefore most of the power at these frequencies is usefully developed in the speaker. At low frequencies, however, the impedance of the speaker is lower

than that of AB, therefore the greater proportion of the LF power is wastefully dissipated in AB, relatively little being delivered to the loud speaker. See Fig. 2, curve C.

It will be seen, therefore, that neither of these apparently simple methods is of

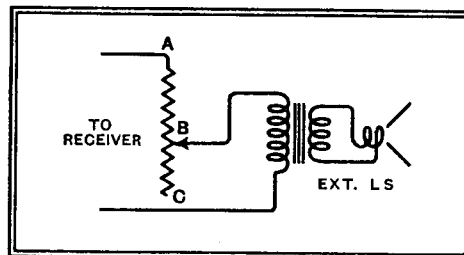

Fig. 3.—A series resistance causes bass attenuation.

much use, so we will reconnect our volume control as in Fig. 1, and add a condenser as shown in Fig. 4. We will consider the actual capacity required later, but it must be so chosen that it will offer a high reactance to low frequencies.

At full volume the condenser is, of course, short-circuited and will obviously have no effect. The effect of the condenser is to by-pass the high frequencies, so that they do not have to flow through AB. As the frequency is increased so the impedance of the condenser C decreases, so that if it could be considered alone its effect on the frequency response would be shown as in Fig. 5. Now, the low frequencies must all flow *via* the potentiometer, and are accordingly reduced, but as the frequency is increased more and more of the speech currents flow *via* the relatively low impedance path offered by C and are consequently not attenuated to the same extent.

We have, in effect, combined the two curves B and D, Figs. 2 and 5, to produce curve E, Fig. 6, which is obviously nearer the ideal.

The value of the condenser depends

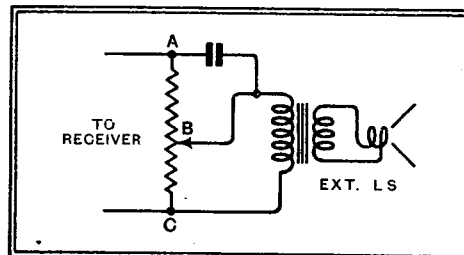

Fig. 4.—A condenser connected as a compensator.

Loud-Speaker Volume Controls—

upon the resistance of the control to some extent. If C is too large (say 2 mfd.), then AB will be short-circuited at all but the very lowest frequencies. On the other

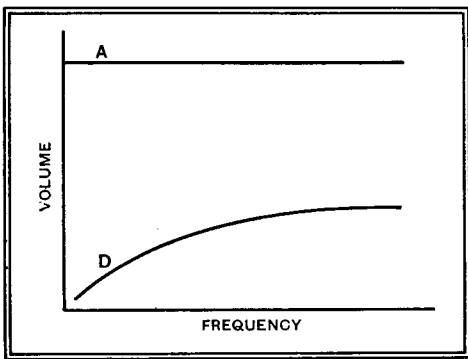

Fig. 5.—Showing the effect of a condenser.

hand, BC will still cut off the high notes, so that what little control we do get by varying the potentiometer will be limited to the high notes only. If C is too small then it will have little or no effect in correcting for the loss of treble caused by BC. As the capacity is increased so our treble is replaced until we reach a point where quality is sensibly unaffected at all but the lowest levels, as will be seen later.

The exact value of the condenser is best found by trial and error, using a pre-set condenser, but as a guide it should be stated that the writer found that with a Mazda AC/PEN output valve, moving-

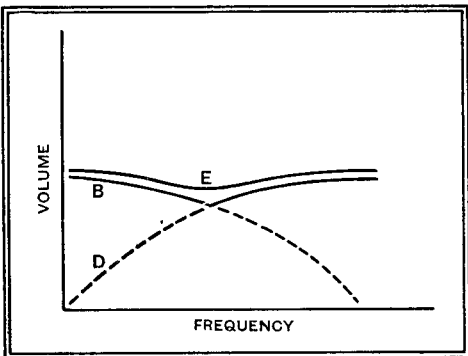
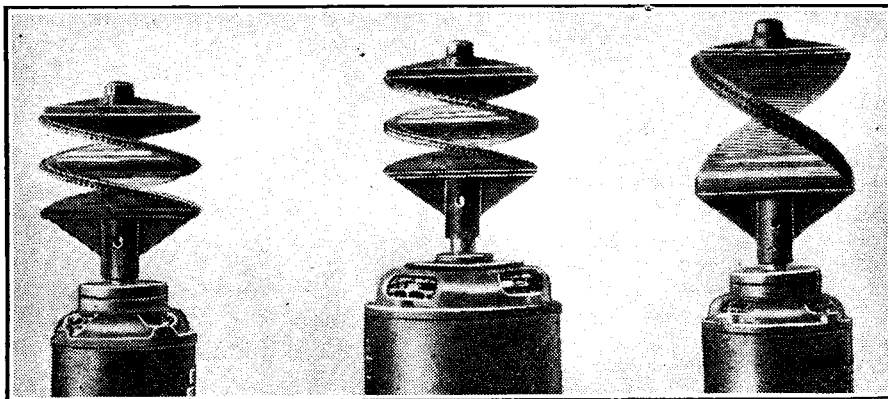

Fig. 6.—Curve E represents the sensibly level response brought about by the control system advocated.

coil speaker to match, and a 50,000-ohm volume control connected across the extension speaker transformer primary a value of 0.008 mfd. gave satisfactory results. Incidentally, any tendency which



MIRROR SCREWS. This photograph, recently received from Berlin, shows Tekade 90-line mirror screws designed for speeds of rotation of 1,500 and 3,000 r.p.m.

C may have to resonate with the speaker transformer is counteracted by the resistances AB and BC.

While the arrangement of Fig. 4 is a great improvement on that of Fig. 1, a little thought will show that at very low volume the shunt BC is so low that in order to preserve the balance between treble and bass, C must be made so

A CURIOUS METER FAULT

WHAT is the remedy when an electrostatic meter reads backwards? With a moving-coil meter of course the answer is easy—simply change over the connections. Certain types of moving-iron meter are also unidirectional in their action, that is to say they will read backwards if the connections are the wrong way round, although as a general rule a moving-iron meter is independent of the direction of the current and can therefore be used for AC or DC.

The type of moving-iron meter which is dependent on current is the polarised type in which the magnetic field produced by the coil is assisted by a small permanent magnet located close to the small moving-iron armature.

An electrostatic meter, such as is used for the measurement of fairly high voltages, should be entirely independent of the direction of the applied voltage. It consists really of a very light and delicately made variable condenser, the moving plates of which are lightly pivoted and attached to a pointer. If a voltage is applied across the plates there is an electrostatic attraction between them which causes the moving plates to rotate. The stronger the voltage the greater is the rotation, and as the voltage on fixed and moving plates is always opposite, there is always an attraction between them irrespective of the actual polarity of the voltage connected to the terminals.

It sometimes happens, however, that a meter of this type will be found to read backwards, even on AC. A particular case arose a short while ago with a meter which had been reading quite normally in a hook-up. The circuit was subsequently tidied up and the meter wired permanently, when it was found, on

switching on again, that the instrument read backwards. After some investigation this was found to be due to the fact that the case of the instrument was in contact with one of the terminals. This particular meter had been designed to operate with the case isolated, and the accidental contact with the case was setting up an electrostatic field inside the meter which was sufficiently powerful, in comparison with that existing between the fixed and moving plates of the mechanism itself, to upset the balance and cause the movement to read backwards in a similar manner to the moving-iron mechanism previously mentioned.

J. H. R.

Graham Farish Short-wave Valve

AMONG the range of Ring valves marketed by Graham Farish, Ltd., of Bromley, Kent, is a battery type, the SWG2, of special interest to short-wave enthusiasts. It is a screen-grid valve with a filament rated for 0.2 ampere at 2 volts, and is fitted with a four-pin base and top-cap. Contrary to the usual practice, the control grid is brought out to the top-cap and the anode to the base, the grid-pin on the base being used for the screen-grid connection. This is done in order to improve the insulation between the grid and filament, and with this same end of high insulation in view the base is made of ceramic material instead of the usual bakelite moulding.

The valve is rated for an anode potential of 150 volts and 80 volts for the screen grid. A mutual conductance of 1.5 ma/v is claimed with an internal AC resistance of 333,000 ohms. The grid-anode inter-electrode capacity is stated to be only 0.002 mmfd. The valve is priced at 13s. 6d.

The Snap rigid valve holder made by this firm is of the four-pin type and is designed to have a very low capacity between the sockets. It is made of ceramic material and priced at 9d.



Graham Farish
SWG2 battery
valve.

Super Regeneration on the Ultra-Short-Waves

Quenching at High Frequencies

By H. B. DENT

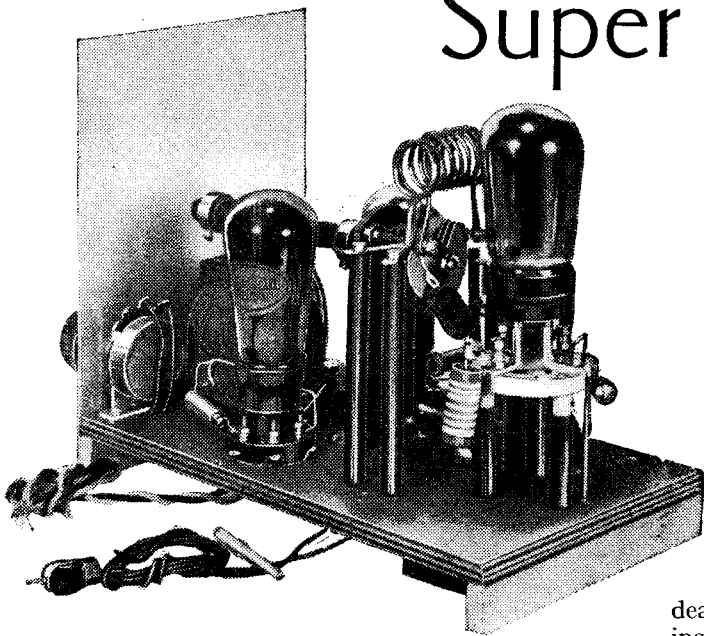

*H*ITHERTO little information has been available regarding the action of super-regeneration, but recent investigations have revealed many interesting facts, some of which are discussed in this article

THE method of amplification developed by E. H. Armstrong some eleven years ago and which he described as super-regeneration has, after a long period of quiescence, come once more to the fore in connection with ultra-short-wave reception. It is unquestionably the most efficient and most economical system for use at these very high radio frequencies. Receivers embodying this principle are not particularly selective, but for amateur experimental work on the ultra-short-waves high selectivity is not essential, since comparatively few stations are working regularly on this band at the same time.

Quenching frequencies of between 5,000 and 8,000 c/s were generally employed in the early super-regenerative sets, but when the principle came to be applied to ultra-short-wave reception, it was found that lifting the quench frequency to just outside the audible range, in the region of 20,000 to 25,000 c/s, did not adversely affect the performance, but it did obviate the need for quench-suppression filters in the LF amplifier.

Optimum Quench Frequency.

In the past there does not seem to have been any serious attempts made to ascertain by laboratory measurements the effect of quenching at different frequencies, or whether there is an optimum quench frequency for any given signal frequency, or the effect of the amplitude of the quenching on the sensitivity of the set. So the design of super-regenerative receivers has been very largely a matter of trial and error.

In the Proceedings of the Institute of Radio Engineers for August last there is a paper by Hikosaburo Ataka, of the Meidi College of Technology, Tobata, Japan, that covers very fully all these aspects of super-regeneration as applied to the ultra-short-waves. The subject is

dealt with under four headings, viz., Theory of Quenching Action, Experiments on Quenching Action, Effects of Signal Wave, and Amplification by Super-regeneration respectively.

The last-mentioned section is especially interesting in that it contains some very informative curves. It is shown that there is a marked improvement in the sensitivity with relatively high quench frequencies, and that the amplitude of the quench oscillations also affects the sensitivity. For a five-metre signal the optimum quench frequency is between 150 and 200 kc/s, provided the amplitude of the oscillations is large, but as the quench voltage decreases the optimum frequency falls lower down the scale.

In Fig. 1 is reproduced the curves relating to these measurements. Each curve is for a different value of quench voltage, but otherwise the operating conditions of the set were maintained constant. With but ten volts injected by the quenching circuit, the optimum frequency is

approximately 50 kc/s, whereas if 50 volts can be obtained, a very marked increase in sensitivity follows by raising the frequency to about 180 kc/s.

There is also an optimum detector voltage, but this will be governed by the circuit design and by the type of valve employed. The most sensitive state is when the detector is lightly oscillating, but not so feebly that the quenching voltage completely suppresses the self-excitation, whilst too vigorous oscillation leads to a decrease in sensitivity.

A super-regenerative receiver should be provided, therefore, with a control for the

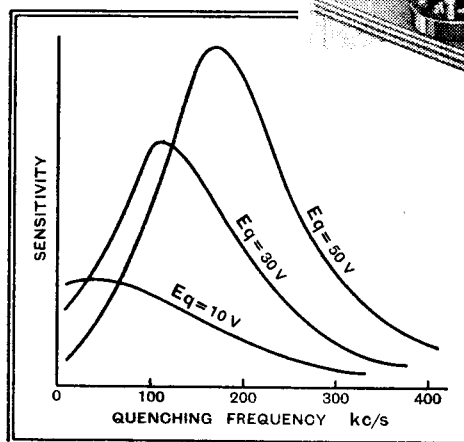
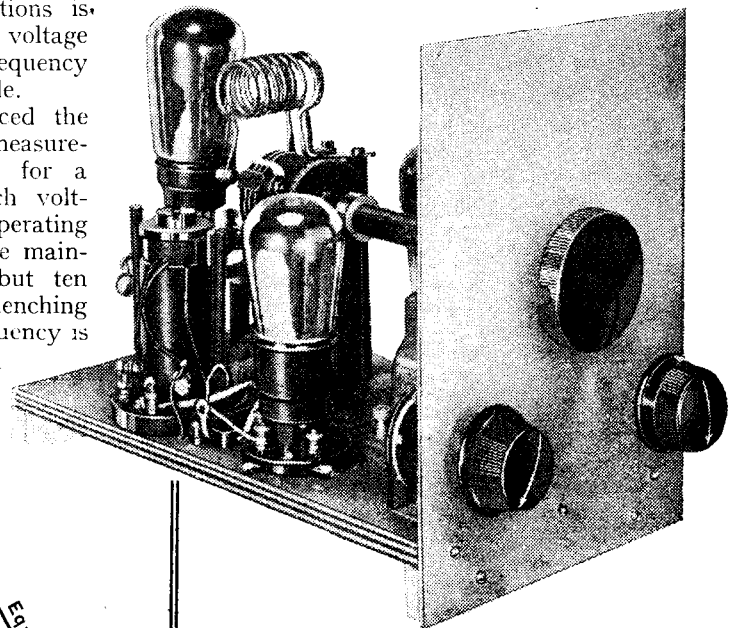

Fig. 1.—Curves reproduced from the Proceedings of the Institute of Radio Engineers, August, 1935, showing the variation of sensitivity due to the quenching action in a super regenerative receiver.



An experimental five-metre receiver fitted with a 100 kc/s quench oscillator.

detector self-excitation, which can be effected by a variable resistance in the HT supply to the valve. Another method is to operate the detector at a relatively high anode potential, say, about 100 volts or so, and restrict the amplitude of the self-excited oscillations by damping the circuit. In cases where an aerial of any description is used, it is only necessary to tighten the coupling until the desired damping of the

Super Regeneration on the Ultra-Short-Waves—circuit is obtained. A variable aerial coupling is exceedingly useful with super-regeneration, but it is advisable also to include a variable resistance in the HT feed to the detector as mentioned earlier, since the most sensitive state is somewhat critical, and either method of control singly may not always suffice.

employ a standard 110 kc/s IF transformer, though to fit nicely into the circuit of Fig. 2, it will need to have a tapping on one of the coils. Variable coupling between the primary and the secondary would be an advantage, but is not essential.

The Varley BP42 and BP84 IF transformers comply with these requirements,

to single-circuit. A small "band-spreading" condenser which also comes into action does much to facilitate tuning on this band.

As is to be anticipated, selectivity on both medium and long broadcasting bands proves to be vastly superior to that of the ordinary single-circuit detector set; an important point is that there is no need to press reaction to the extent of spoiling quality in order to get freedom from interference. On the short waves performance is equally satisfactory, considering the simple nature of the circuit.

The second receiver is more conventional, and embodies a straightforward HF-det.-LF arrangement with two tuned circuits and pentode valves in all positions. The HF pentode acts as a buffer valve for short-wave reception. As the detector is a high-

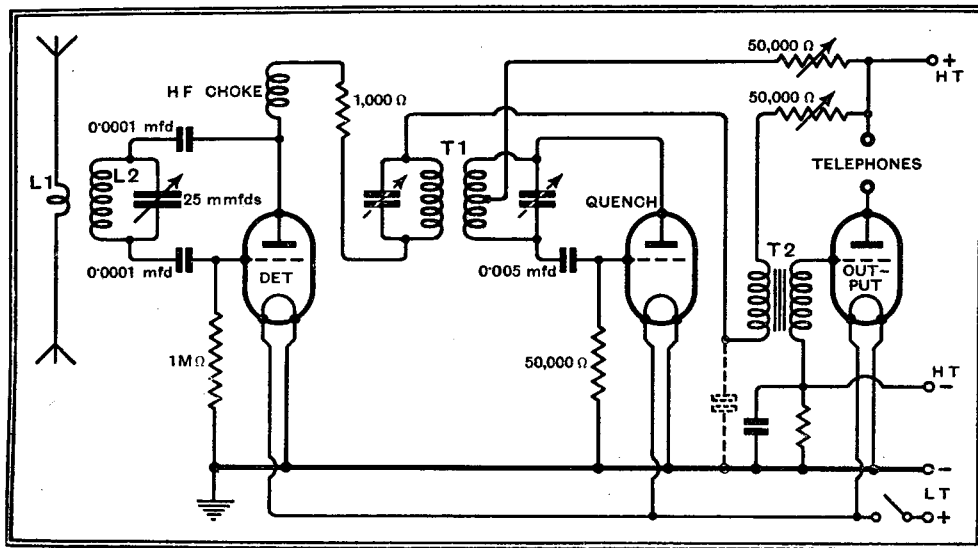

Fig. 2.—Theoretical circuit of a three-valve super regenerative five-metre receiver using a quenching frequency of 100 kc/s.

In an experimental receiver in which a high-frequency quench oscillator was employed, it was found necessary to use a power valve in order to obtain a sufficiently large quench voltage at some of the higher frequencies. The quench voltage was injected into the anode circuit of the detector as shown in Fig. 2. Although the sensitivity may be better with quench frequencies as high as 200 kc/s, it was not so marked an improvement over that at 100 kc/s as to justify the difficulty in obtaining some fifty volts or so from the quench oscillator in small portable super-regenerative receivers of the type customarily used for outdoor experiments.

For the lower frequency it is possible to

and there are, of course, other makes that will serve just as well. The optimum voltage for 100-110 kc/s quenching can be developed across the tuned pick-up coil T1 in Fig. 2, by using a small power valve in the quenching oscillator and by suitably adjusting the coupling.

The higher quench frequencies are accompanied by the characteristic background noise as with the lower frequencies.

No improvement can be expected in the selectivity, for the rather poor showing of the super-regenerative receiver in this respect is inherent in the system; the presence of component frequencies brought about by the quenching action is largely responsible for the spreading of the signal.

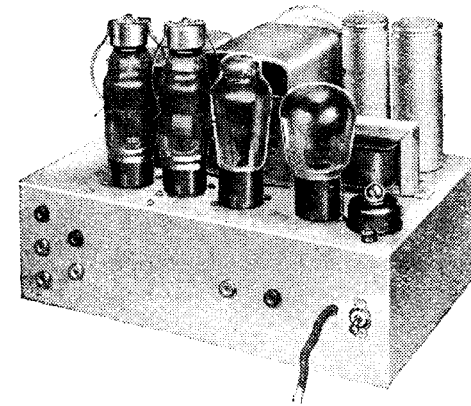

The "all-pentode" HF-det.-LF model, like its companion 2-valve set, covers short waves between 20 and 60 metres as well as the normal broadcast bands.

impedance pentode, a resistance in series with a high-inductance choke is used as an LF coupling in its anode circuit. Performance on all bands is satisfactory. Parts for this set cost £9 9s., and for the 2-valve receiver £7 10s.

Solder Through the Ages

SOLDER is an almost indispensable, though perhaps humble, constituent of wireless apparatus of every kind, but it will come as a surprise to most readers that a 54-page book—and an interesting one at that—can be written on its history, composition, and uses.

According to Pliny, the Roman plumbers' *tertarium* consisted of an alloy of one part of tin to two of lead; the modern plumber's solder has practically the same composition. The Roman *argentarium*, or general-purpose solder, consisting of equal parts of tin and lead, is widely used to-day.

But it must not be thought that there has been no progress in this branch of the metal-worker's art. New alloys and processes are constantly being introduced; the book gives information on such subjects as the soldering of stainless steel, electric soldering by the passage of current through the objects to be heated, and the operation of modern soldering machines, as well as on the simpler aspects of the subject.

"Solder," the title of the book in question, is Bulletin No. 2 of the International Tin Research Council. Copies may be obtained free of charge from the offices of the Council at Manfield House, 378, Strand, London, W.C.2.

High-Voltage Valve Sets

All-wave : Universal Mains

NEW kits of parts for the construction of several types of receivers are now being issued by Eugen Forbat, 28-29, Southampton Street, Strand, London, W.C.2. All employ the Ostar-Ganz universal mains valves, which, as most readers know, embody heater elements rated at the full mains voltage; they may therefore be connected in parallel across the supply terminals without any special precautions.

We have recently had an opportunity of testing two all-wave receivers built from these kits. The first is a comparatively simple detector-LF set which includes a refinement that should be much more common than it is—a two-circuit aerial tuning system. This is controlled by a two-gang condenser provided with an external trimmer by means of which compensation for the disturbing effect of reaction may be made.

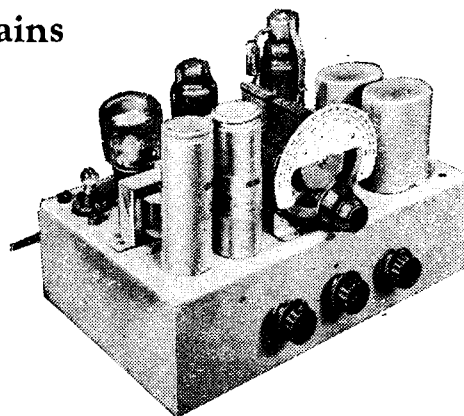

A selective detector-LF set: this Ostar-Ganz model, available in the form of a kit of parts, includes two-circuit aerial tuning.

For short-wave reception, the change-over is effected by means of a multiple switch, which converts the tuning system

CURRENT TOPICS

Algiers to Tell Europe

M. CARDE, Governor-General of Algeria, announces that the power of Radio Algiers is to be increased so that "its powerful voice will be audible throughout the whole of Europe." At present the station works on 318.8 metres with a power of 12 kilowatts.

Italian Radio in Abyssinia

OF the three broadcast transmitters in Addis Ababa, the most costly and up to date is of Italian manufacture. The second station incorporates apparatus from Britain, France, Germany, and Sweden, while the third is privately owned and was built by a young Frenchman, M. A. de Reffy, son of the French Chargé d'Affaires in Abyssinia. Its call sign is ET8FA.

Edinburgh Radio Show

EDINBURGH'S radio exhibition is now in full swing at the Waverley Market and is open from 2 to 10 p.m. daily.

Special features include a studio enabling visitors to try out their voices before the microphone, a Post Office exhibit dealing with interference, the Café Colette Orchestra, conducted by Walford Hyden, and the B.B.C. stand, which exhibits scale models of the Droitwich transmitter.

A large section of the show is, of course, devoted to the stands of radio manufacturers. The exhibition remains open till October 19th.

Luxembourg's Wavelength Seized

GERMANY, taking advantage of Luxembourg's decision to remain on the long waveband, is seizing the medium wave allocated to the 200-kilowatt station under the Lucerne Plan. This is the wavelength of 240.2 metres, which is being used by the 0.7-kilowatt transmitter at Saarbruecken. A 1.5-kilowatt station will shortly replace this, and next year a suitable site is to be chosen for the erection of a 17-kilowatt station.

At present the Saar Territory has no local German broadcasting service, as Trier and Kaiserslautern operate on a common wave together with Frankfurt.

Postmen v. Poachers

FRENCH postmen are now empowered to collect radio licence fees. To encourage them in the pursuit of the radio "poacher," M. Mandel, the P.M.G., has decided that for every licence fee collected the

postman shall receive a commission of 2 francs.

Another device for outwitting the non-paying listener is the new decree that dealers, when selling a set, must send a declaration to the Post Office in the area in which the purchaser resides.

M. Mandel is not acting too soon, for recent investigations go to show that at least a third of the sets in use in France are unlicensed.

Wireless and Music

HOW wireless has revolutionised the world of music was commented on by Sir Landon Ronald last week.

"The gramophone, with which I have been closely associated for forty years," said Sir Landon, "began the revolution, and broadcasting suddenly completed it. The smallest and re-

Noise

"**N**OISE" is the title of a lecture to be given by Mr. L. E. C. Hughes, Ph.D., D.I.C., under the auspices of the Institution of Electronics at King's College, Strand, W.C.2, at 7 p.m. on Tuesday next, October 15th.

Broadcasting from Abyssinia

"**T**HIS battle is coming to you by courtesy of Pork Packers, Inc.," is the announcement for which many American listeners are waiting. Strenuous efforts are being made to link up with Abyssinia, but the American naval radio men who hope to set up a short-wave station in Ethiopia regard it as a certainty that the Italian aircraft will lose no opportunity of wiping out all radio stations in the attacked country. Experts in Washington, however, believe



GUIDE, PHILOSOPHER AND FRIEND is the role played by the ultra-short-wave transmitter and receiver carried by forest scouts in Maine, U.S.A., whose task it is to keep in touch with forest parties during the hunting season.

motest cottage now has better supplies of fine music than could have been demanded by the wealthiest patron of music at any other time in the world's history."

Programme Pooling

THE Scandinavian countries—Denmark, Norway, Sweden, and Finland—are joining forces for the exchange of important broadcasting programmes. This should secure a higher standard of programme material without involving individual countries in more cost. Incidentally, this suggests a time when all Europe will pool its broadcasting resources so that two alternative programmes may suffice from Belfast to the Bosphorus

that it is more than likely that Abyssinia has a number of portable wireless transmitters.

Certain it is that the demolition of the State radio transmitter at Addis Ababa and the cutting of the telegraph wires to Djibouti would be a severe blow for dozens of newspaper correspondents, who would then have to depend upon runners to get their despatches through to the radio stations at Asmara, in Italian Eritrea, Djibouti, in French Somaliland, Berbara, in British Somaliland, and Mogadishu, in Italian Somaliland.

America is searching for precedents for the establishment of a broadcasting station by neutrals in a foreign country for the transmission of war news, and can find none.

EVENTS OF THE WEEK IN BRIEF REVIEW

British Sets in India

ALTHOUGH British manufacturers exporting to India have an advantage of 10 per cent. in Customs duties, the United States supplies nearly double the amount of radio material furnished by Great Britain. In the year 1934-35 India imported radio apparatus as follows:—

	Rupees.
United Kingdom ...	466,316
Germany	77,574
Holland	155,407
United States	830,348
Other countries	65,200

In the previous year the United Kingdom led the market with apparatus to the value of 571,971 Rs., and the United States came next with 178,944 Rs.

N.R.E.A.

THAT the demand for skilled radio engineers is far beyond the supply is the discovery made by the employment bureau of the National Radio Engineers' Association, Ltd. According to the September issue of "Service," the Association's monthly bulletin, callers at the N.R.E.A. temporary premises near Addison Road Station during the radio show came from places as far apart as Penzance and Aberdeen. Investigation showed that, almost without exception, the industry and trade are in sympathy with the objects of the Association. Paid membership figures have increased by 76 per cent. since July 1st.

The Radio Companion

A REALLY pocket wireless set is to be described in the issue of *The Wireless World* of October 25th. This receiver employs three of the midget valves made by Hivac, serving the purposes of detector and two LF stages. The set measures 7½ in. x 5 in. x 1½ in., batteries and frame aerial being included in these dimensions. The set gives satisfactory headphone reception up to a range of 50 miles from a B.B.C. station.

A New Organ

"**T**HE Magnetron" thermionic organ is among the novelties on view at the Inventions Exhibition at the Central Hall, Westminster. Regular demonstrations are given, Epoch super cinema loud speakers being used.

The Development of the

By **COMMANDER J. A. SLEE,**
R.N. (Ret.), C.B.E.

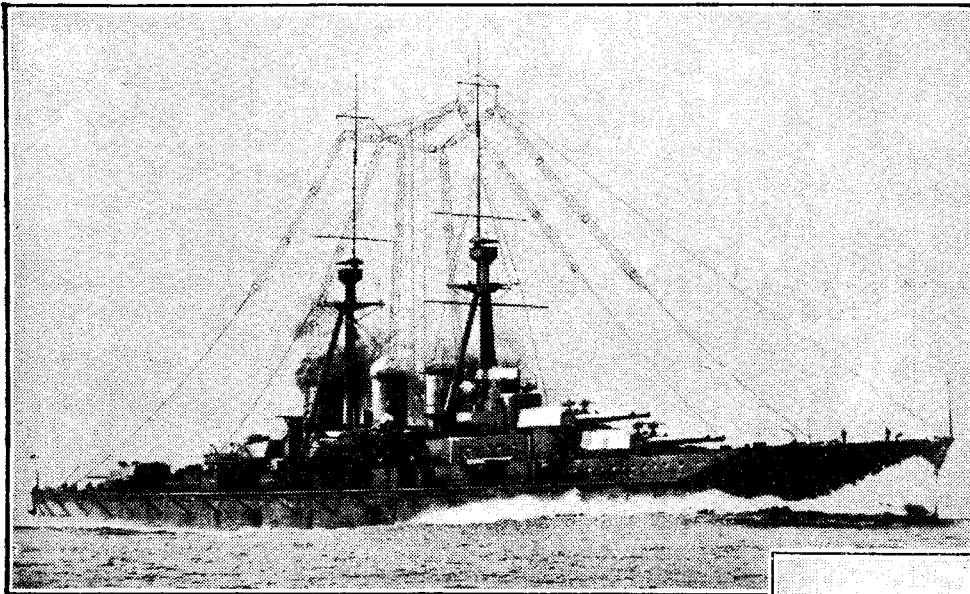

An interesting pre-War aerial arrangement on the Japanese cruiser "Kongo."

Part III.—Post-War to the Washington Conference, 1927

AFTER the acute pressure of the War had had time to die down, and some hurried developments had been fully examined and applied to other purposes, the period of accurate measurement commenced.

THE first great aerial advance after the war was the determination of the nature and extent of the losses due to eddy currents in the surface of the ground under and near to the transmitting antennæ of a high-power station. These losses were overcome by shielding the surface with a screen of copper wires. This was no light undertaking, as the screen had to be supported above the ground, and its area was about four times that of the aerial itself. It was very effective, and raised the efficiency of the aerial to about 50 per cent.; that is to say, it reduced the total resistance of the aerial to a value about equal to twice that of the radiation resistance.

Experiments were also commenced in directional transmission, the directional effect being developed by the interference effects between the radiation of two neighbouring aerials in which

(Right) An early Bellini-Tosi D.F. loop on board ship.

(Below) A complicated earth-screen which raised aerial efficiency by 50 per cent.

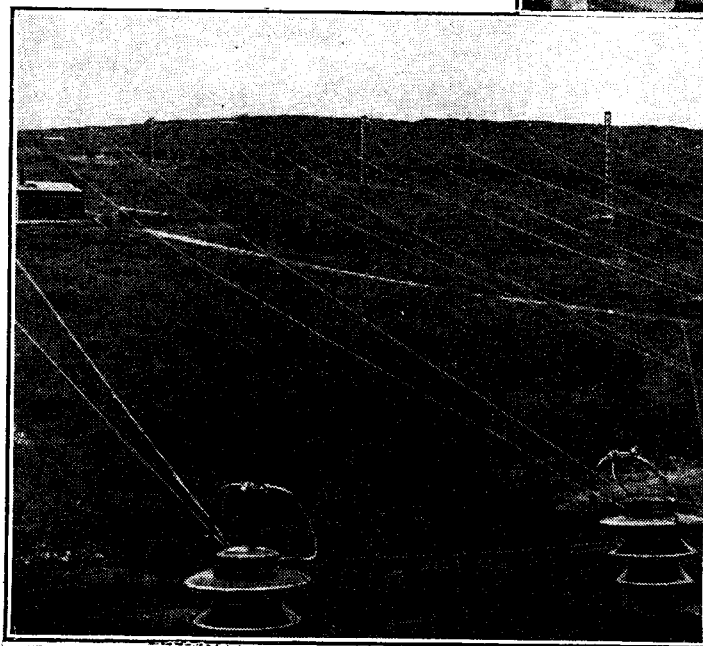
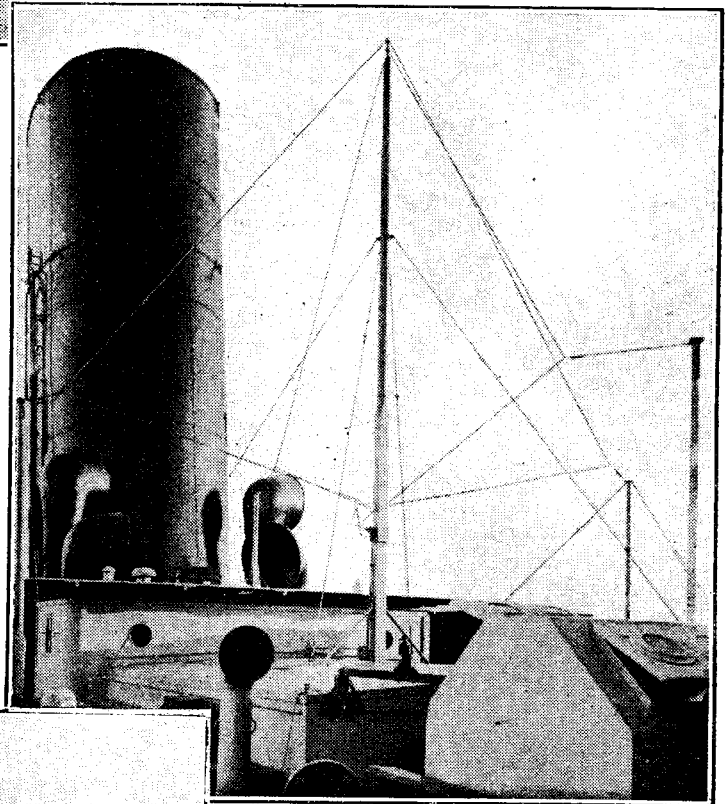

current of the same frequency flows. The directional effect is controlled to some extent by the phase relation and strength of the current in the two aerials, and on the distance separating them.

It is probable that the original object was to obtain a more definite minimum of transmission than could be obtained with the use of long horizontal aerials, so that there should be a definitely silent zone in which the receiving station associated with the transmitter could be placed.

The action was, of course, reversible, a minimum direction of reception being pro-

duced in the same way and to the same extent as the minimum direction of transmission. The principle consisted in the erection of two vertical aerials half a wavelength apart, and the practical difficulty lay in the size and cost of the very large aerials required for the very low frequency waves which were then in use for all long-distance communication.

The effects which had been developed for the purposes of direction-finding during the war were also applied to reception, the cosine or the cardiac diagram being used at will so as to be able to cover the direction of any interfering signal with the zero of reception. The unidirectional reception of a very long, low aerial with a suitable buffer circuit at its outer end was brought into service during this period of develop-

Wireless Aerial

ment. The magnificent transmitting station at Rugby was completed during this period, and it still remains the last word in long-wave all-round transmitting stations. This station was also the cradle of the Transatlantic telephone service.

Its aerial system is supported on twelve masts 820 feet high, eight of them being arranged in an irregular octagon to carry the main aerial for telegraphic transmission at a frequency of about 18 kilocycles per second, and the remaining four being used to support the aerial extension for the Transatlantic telephone service. The long-wave part of this service is carried out at a frequency of about 75 kilocycles.

D.F. Difficulties on Ships

There were no striking developments in transmitting aerials for small or mobile stations, but the use of direction finders for navigation purposes in the mercantile marine commenced. Two types of apparatus were developed, the Bellini-Tosi and those using a small rotatable frame aerial. The outstanding problem was to reduce the size of the frame or aerial without loss of accuracy due to the exceedingly unfavourable position of an aerial on board a steel ship and close to the funnels, masts and rigging, etc., a great deal of which shielding is not permanent.

Satisfactory methods of shielding were evolved during this period, resulting in the present well-known construction which consists of a small frame aerial having seven or eight turns of wire enclosed in an

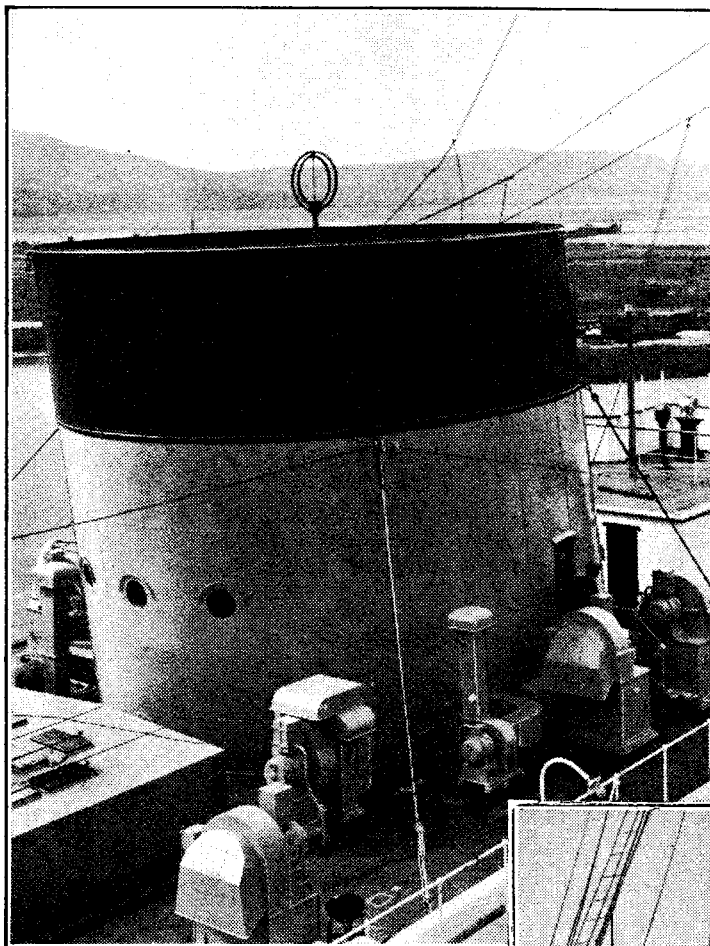

Marconi-Bellini-Tosi loop in the dummy funnel of the liner "Georgic."

earthed metallic tube which is not electrically continuous.

The greatly improved receiving apparatus which was now available revealed the fact that very high frequency transmissions could be received at great distances, although they could not be received at moderate ranges. The existence of the skip zone was clearly proved, and attention was again directed to the possibilities of short waves for long-distance communication. For many years they had been generally considered to be useless for this purpose, and, indeed, for most others, their return to the surface of the earth outside the skip distance never having been demonstrated.

Early Directional Transmission

Wireless telephony had been well established during the war, chiefly for aircraft communication, and during this period the use of wireless telephony for entertainment purposes commenced, and was carried to a high state of development, first of all in the United States.

The value of short waves for long-distance communications having been established, attention was turned to the possibilities of directional transmission. The theoretical principles involve the immut-

able fact that the physical dimensions requisite are proportional to the wavelength, and structures which were quite impracticable when the unit of length which must enter into their design was that of a wavelength of many thousands of metres became comparatively simple from an engineering point of view when the unit of length was reduced to a few tens of metres.

The first experiments were carried out by means of a reflecting system of parabolic form with the transmitting aerial at its focus. The construction of the reflector, consisting of a large number of vertical wires erected round the periphery of a parabola was very difficult, but the concentration of all the energy radiated into a fairly narrow

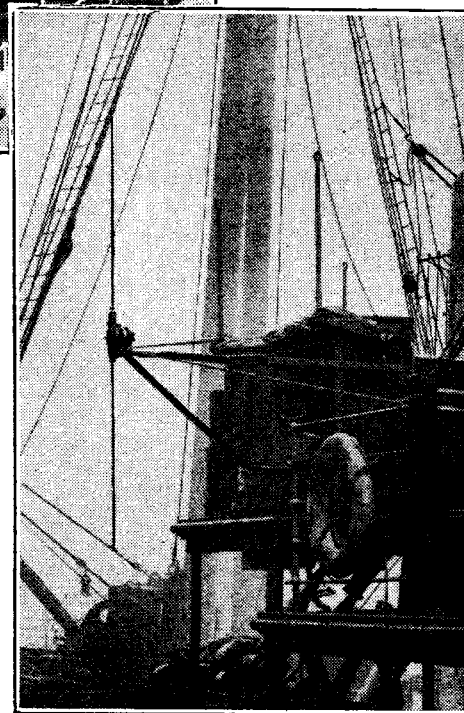

Beam receiving antenna on S.S. "Royal Scot."

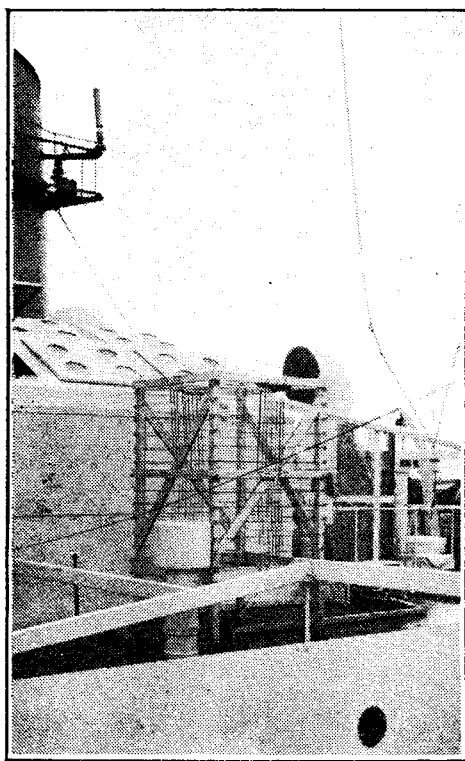

A later development of the Bellini-Tosi D.F. aerial.

beam was definitely achieved. Its measured performances compared well with its theoretical efficiency, both as a transmitter and a receiver.

The Washington Radiotelegraphic Conference of 1927 was called upon to consider a new set of conditions arising out of improved methods of communication and the successful exploitation of wavebands which had formerly been regarded as of insufficient commercial utility value.

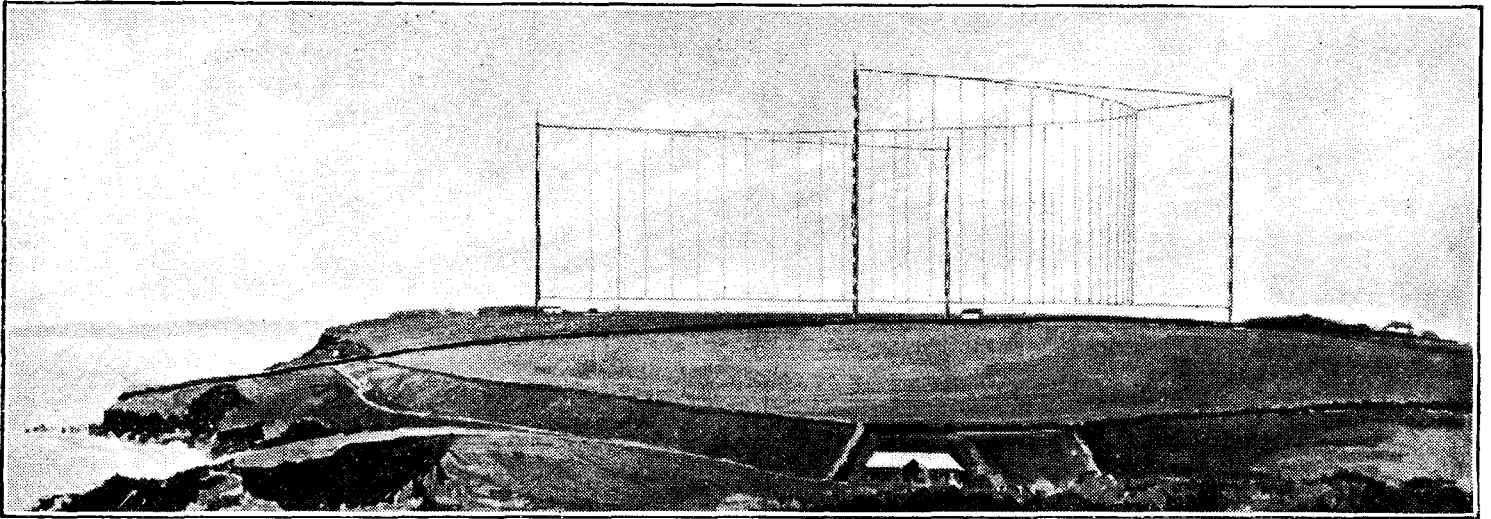

An early attempt at directional transmission. A parabolic reflector at Poldhu which concentrated the radiated energy into a fairly narrow beam.

Shortly before the Conference simpler but no less effective methods of construction were adopted, and the short-wave "beam" station, formerly regarded as an experimental curiosity, had become the wireless station not of the future but of

the present for all long-distance communication between fixed points.

These stations, and the enormous growth of broadcasting, brought about a complete revolution in the world of wireless.

(To be concluded.)

THE RADIO INDUSTRY

DAVENSET mains equipment and components are now available for demonstration and inspection at 167, Shaftesbury Avenue, London, W.C.2. Mr. G. F. Bedford, B.Sc., has recently been appointed as London Manager by the makers, Partridge, Wilson and Co., Ltd.

The new season's catalogue of Siemens Full-O'Power radio batteries is now available from Siemens Electric Lamps and Supplies, Ltd., 38-39, Upper Thames Street, London, E.C.4. A companion list deals with other types of dry-cell batteries, several of which find application for wireless purposes.

The Chloride Electrical Storage Company has been awarded a Diploma of Honour for its exhibit at the Brussels Exhibition.

The latest catalogue of Bryce products gives full information as to weight and dimensions, in addition to electrical characteristics, of the various components made by W. Andrew Bryce and Co., Woodfield Works, Bury, Lancashire. These include power transformers, chokes, condensers, resistances, loud speakers, etc. Several pages are devoted to general technical information and circuit diagrams.

A new catalogue of Kabi components—potentiometers, multi-contact switches, hum balancers, rheostats, and switches, etc.—has now been issued by F. W. Lechner and Co., Ltd., 61, Spencer Street, Clerkenwell, London, E.C.1.

Thanks to the use of an improved process, it is claimed that the capacity of the Pertrix Maroon Carton batteries is increased by 20 per cent; also that "shelf-life" is exceptionally long.

A radio service-man's test bench which can be constructed for about 30s. is described in the latest Philco technical leaflet issued to members of Radio Manufacturers' Service.

A booklet giving much useful information on electro plating and metal finishing generally (with special reference to the "Epalex" system) is issued at a cost of 1s. (post free) by B. J. Round and Sons, 8-10, Northampton Street, Birmingham.

Electric furnaces, including several of small size and low cost, suitable for laboratory use, are described in a catalogue issued by Wild-Barfield Electric Furnaces, Ltd., Elecfurn Works, North Road, Holloway, N.7.

A Short-wave Frequency Doubler

MOST of the modern development of the cathode-ray tube is so closely bound up with scanning in television that one is apt to overlook its utility in other directions. The Figure, for instance, shows an ingenious scheme for using it as a frequency-doubler in ultra-short-wave signalling.

The ordinary fluorescent screen is replaced by an annular electrode P, formed of a strip of insulating material bounded by inner and outer conducting wires, which are connected respectively to the two limbs of a Lecher-wire coupling to a dipole aerial. Inserted at intervals along the insulating strip are a series of small "targets," connected alternately to the inner and outer conductors, so as to feed intermittent pulses of energy from the cathode ray to the aerial.

The discharge stream through the tube is focused, as usual, by a negatively-biased cylinder C, so as to pass through the centre of the anode A. Once past the anode the stream comes under the influence of a pair of deflecting plates which cause it to trace out a circular path over the annular target.

Ultra short-wave oscillations from a source O are applied direct to the first pair of deflecting plates, as shown. Owing to the distance separating the first pair of deflecting plates from the second it is necessary to introduce a definite phase-difference in the voltages applied to the second pair of plates, in order to ensure that the stream follows the required circular track. Accordingly, the upper pair of plates are fed from the lower through a Lecher-wire coupling, fitted with a "trombone" section for fine adjustment.

The speed at which the cathode ray

traverses the annular strip is, of course, determined by the frequency of the oscillations from the source O, whilst the multiplied frequency fed to the aerial

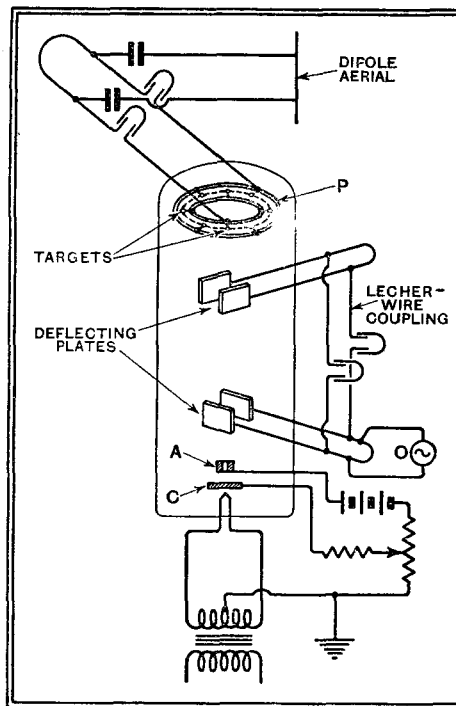

A special form of cathode-ray tube used as a frequency multiplier. The output radiated from the dipole aerial has a frequency four times greater than the input from the source O.

depends upon the number of pairs of "targets" inset in the annular strip. Using eight targets, as shown, the frequency taken out of the tube is four times that fed into it from the source O.

HINTS and TIPS

Practical Aids to Better Reception

AIR spaces of greater or lesser size are apt to appear in the jelly-electrolyte type of accumulator. Such a condition should not be allowed to persist, but, as often as not, no amount of shaking or bumping will cause the spaces to fill up.

Jelly-Electrolyte Accumulators

However, there are several ways in which such air spaces can be made to disappear. One method is to connect a pump, of the bicycle pattern, to the vent hole by means of a short length of tubing and a non-return valve. A few strokes of the pump will cause the pressure inside the cell to increase, and, providing there is no escape for the air, this will be sufficient to fill up the cavity.

Another way of achieving the same result is to seal up the vent hole while the cell is on charge and gassing vigorously. Again, the pressure inside will increase, but it is obviously important for discretion to be used, and, as soon as the air spaces are filled up, pressure should be released, or otherwise the container may burst.

IN a recent article dealing with the measurement of ultra-short wavelengths, the absorption principle was described as the amateur's fairy godmother. The description is an apt one, for by the use of this principle a number of operations and experiments that would normally be beyond the scope of the amateur can be carried out with the simplest and cheapest gear.

A Fairy Godmother

But, so far as wavelength measurement on the normal broadcasting bands is concerned, the absorption meter has recently suffered an eclipse through the general adoption of AVC. With the absorption wavemeter, resonance is indicated by weakening of signals when the meter is tuned to the same frequency as the receiver; naturally, with AVC in operation

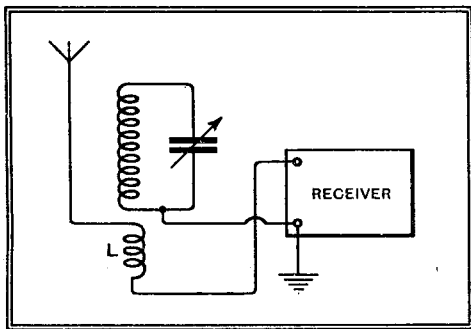

An absorption wavemeter, and the most convenient method of coupling it to a receiver.

this weakening is no longer detectable, as the controlling system automatically "turns on" extra magnification to make good the deficiency.

It is the purpose of this note to point out, however, that the wide adoption of

tuning indicators has again brought the absorption meter into its own. Although a diminution in signal strength resulting from the abstraction of energy by the meter may not be perceptible aurally, it will be clearly shown by the tuning indicator, and in practice the point of resonance can be determined with high accuracy by this method.

For the benefit of those unfamiliar with the absorption meter, it may be briefly stated that it consists of nothing more than a coil and a condenser, as shown in the accompanying diagram. The instrument is most easily coupled to a set by placing the coil in conductive relationship with a three- or four-turn coil (L in the diagram) joined between the aerial lead-in and the aerial terminal of the set.

HIGH-NOTE whistles due to heterodyning by the station occupying an adjacent channel are always annoying and, now that there is a general tendency to increase the frequency range of receivers and loud speakers, probably more in evidence than hitherto, even though stations generally adhere more strictly to their wavelengths.

Cheapest Whistle Filter

The most satisfactory cure for such troubles is, of course, to fit some form of filter or suppressor, and many effective designs are available. But in cases where the trouble is of rare occurrence, it is useful to know that a whistle of high pitch may become inaudible if the listener's head is moved slightly—an inch or so will often do the trick.

The position at which this convenient acoustic phenomenon comes into play is that at which a reflected wave from the walls or furniture of the room cancels out the wave received directly from the loud speaker.

THOSE who are seeking to improve the quality of their reception with particular regard to the high-note response may be interested to know that the upper frequency radiation of most medium-priced loud speakers, particularly the older models, may usually be improved by reinforcing the centre of the cone. By way of warning, it

Higher Fidelity

should be said that these remarks are addressed to those who believe in acting on the kill-or-cure principle, and are willing to run the risk of ruining a poor

loud speaker in the attempt to improve it.

Reinforcement may be carried out by adding split paper rings of gradually increasing diameter, glueing them in the centre with the very greatest care to avoid wrinkles or distortion of the diaphragm, or by doping the cone from the centre outwards with successive thin layers of glue, each layer covering a wider area than the last, and the final one covering about one-third of the cone.

AS almost everyone knows, a switch controlling a domestic lighting or heating "point" should always be wired in the "live" or unearthed mains lead. But it is surprising how often one finds the switch wrongly connected in the "dead"

The Careless Electrician

lead, and it is still more surprising such a fault is allowed to pass undetected during the tests that are presumably carried out on all domestic electrical installation.

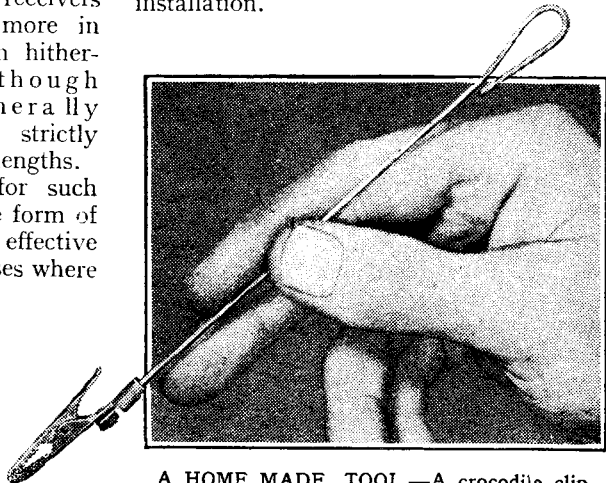

A HOME MADE TOOL.—A crocodile clip secured to a stiff wire handle is useful for holding wires in inaccessible positions for soldering, etc.

Possibly a fault of this kind may have no serious effect when the electrical outlet is used for ordinary purposes, but it is a distinct source of danger when an earthed wireless receiver is fed from it. In certain circumstances one may switch off at the wall switch and, imagining that the precaution of disconnecting the set is entirely unnecessary, begin to handle the internal wiring without taking any precautions. An unpleasant, if not serious, shock may easily be had in the circumstances, as some at least of the wiring will be at full mains potential above earth.

In cases of uncertainty it is an excellent plan to make sure (by means of a test lamp or voltmeter) that the switch really does isolate the set from the mains.

Listeners' Guide for the W



ALL ABOUT DINNER

Just a little unfortunate, perhaps, is the choice of time for "Dinner is Served"—a feature programme to be broadcast Nationally at 9 p.m. on Thursday next. At 9 p.m. everyone should be in that happy state when the very thought of food is revolting.

However, "Dinner is Served," with its sound records from Smithfield, Billingsgate, and Covent Garden markets, should be good enough to pierce through our armour of repletion. Laurance Gilliam, who is producing the programme, has been wandering round these markets and travelling to the docks, tracing backwards from the dinner table to their origin each ingredient of the average meal.

The meat on your plate and mine will be traced back through the local butcher's shop to Smithfield; through the cold storage and the ships to the grazing grounds of Australia; and so with the fish, vegetables and fruit, which find their way to our groaning boards.

MACBETH ON SUNDAY

GODFREY TEARLE will be heard as Macbeth and Flora

Robson as Lady Macbeth in Peter Creswell's production of the great tragedy in Sunday's National programme at 5.30. A point of special interest is that an attempt will be made to convey over the microphone the manner in which Shakespeare's producers first created the famous characters. The music has been specially written by Victor Hely-Hutchinson.

TWO BANDS IN ONE STUDIO

BOTH the B.B.C. Theatre Orchestra and the Dance Orchestra take part in a novelty programme, "The Bandbox," on Tuesday (National, 8). Stanford Robinson and Henry Hall will both be there to open the bandbox and those who listen will discover its contents.

NELSON KEYS

ONCE again the inimitable Nelson Keys heads the bill of the Monthly Revues. The first of the new series comes to the National microphone at 10 p.m. on Wednesday. The music will again be written by Jack Strachey and the lyrics by such writers as Desmond Carter, Holt Marvell, Beverley Nichols, and Arthur Marshall. Desmond Carter's contribution

is a lyric, "You are my Social Ruin," sung by a gangster and his "Moll." Beverley Nichols offers a sketch about photography, ancient and modern. Arthur Marshall, who has developed the "schoolmistress" style, has lyricised "Mrs. Euclid."

IN THE CAFE

THE B.B.C.'s café complex reasserts itself in the autumn feature, "The Table Under the Tree," to be introduced with the help of Walford Hyden and his band

MEALS IN THE MAKING. A typical scene in Covent Garden Market, a sound picture of which figures in Thursday's feature broadcast, "Dinner is Served." Electrical recordings of Smithfield and Billingsgate markets will also be heard.

on Wednesday next. The table, in a Continental open-air café, has a regular frequenter, Wilfrid Rooke Ley, who enters into conversation with a young English honeymoon couple, played by Joan Carr and Hubert Gregg. The habitué talks of the music of his country, pointing out the various items in the musical programme and relating their history. Finally, he persuades the *maitre d'hotel* (Dino Galvani) to ask the orchestra to play for his English guests.

ALL GIRLS TOGETHER

THE hero of the week is Max Kester, who will "apprehensively assemble" the ten ladies who take part in "All Girls Together"—a challenge to the Stanelli Stag Parties—to be broadcast Nationally at 8 on Thursday. The party will include the Carlyle Cousins, Mabel Constanduros, Jenny Howard, Marjorie Stedeford, Chrissie Thomas, Bertha Wilmot and (at the piano) Jean Melville. These well-known radio artists are out to show us that women can make merry before the microphone as successfully as the sterner sex, and I have no doubt that Mr. Stanelli will be listening.

"BULLDOG DRUMMOND"

SAPPER'S great story, "Bulldog Drummond," in the stage version of which Sir Gerald Du Maurier scored one of his outstanding successes, has been adapted for the microphone by Jack Inglis, and will be broadcast on Wednesday next (Regional, 8.15) and Friday (National, 8).

The plot of the play, which centres round the nefarious activities of a Dr. Lakington, proprietor of a Surrey mental home, will sweep listeners off their feet. The part of Drummond will be taken by Leslie Perrins, and Howard Rose is the producer.

BIRTH OF A HIT

A DANCE tune is on everyone's lips. It is hummed in city offices, sung in basement kitchens, whistled by butchers'



"DINNER IS SERVED." Nelson Keys, the irrepressible, who heads the "bill" in Wednesday's October Revue at 10 p.m. (National).

boys. Where did it come from?

We may perhaps learn the secret by tuning in Kalundborg at 8 p.m. on Sunday, when a programme, "The Birth of a Song Hit," will take us to the den of a composer, the dungeon of a song writer, the palace of a music publisher, and other stations along the road to success.

Week

Outstanding Broadcasts at Home and Abroad

HIGHLIGHTS OF THE WEEK

FRIDAY, OCTOBER 11th.
 Nat., 8, B.B.C. Orchestra, conducted by Malcolm Sargent. 10.20, "The Little Show"—a cabaret entertainment. 10.50, Maurice Winnick and Orchestra. Reg., 8, Recital by the Glasgow Orpheus Choir. 8.45, "Floor Show," with Carroll Gibbons and his Band.

Abroad.
 Stuttgart, 7.15, Symphony Concert from the Liederhalle, including Bach Concerto for 4 pianos and strings.

SATURDAY, OCTOBER 12th.
 Nat., 7, The Saturday Magazine. 8.30, Variety of Music. 11, B.B.C. Dance Orchestra. Reg., 8, Unrehearsed Debate. 9.30, "Pagliacci," from Sadler's Wells.

Abroad.
 Breslau, 7.10, Symphony Concert from the Saal der Redoute, Budapest.

SUNDAY, OCTOBER 13th.
 Nat., 5.30, "Macbeth," with Godfrey Tearle and Flora Robson. Violin Recital by Francescatti. Albert Sandler and the Park Lane Hotel Orchestra.

Reg., Sale and District Music Society. Recital for two pianos: Edith Gunthorpe and Cecil Baumer. Sunday Orchestral Concert, Sixth Season, 1.

Abroad.
 Brussels II, 8, "Das Rheingold" (Wagner) from the Royal Flemish Opera, Antwerp.

MONDAY, OCTOBER 14th.
 Nat., 8, "Shepherds of the Delectable Mountains"—music by Vaughan Williams (from Bunyan's "Pilgrim's Progress"). Songs from the Shows.

Reg., B.B.C. Orchestra, conducted by Joseph Lewis. Talk: "The England I Knew," by Philip Allingham. Jack Payne and his Band.

Abroad.
 Leipzig, 7.10, Beethoven Concert.

TUESDAY, OCTOBER 15th.
 Nat., "The Band Box." Piano Recital by Coquita Fernandez. Serenade by B.B.C. Orchestra. Reg., Reginald King and his Orchestra. Songs from the Shows.

Abroad.
 Radio-Paris, 8.30, French National Orchestra and soloists.

WEDNESDAY, OCTOBER 16th.
 Nat., Harold Samuel (pianoforte) and the B.B.C. Orchestra. 10, Nelson Keys in "October Revue." Reg., "The Table Under the Tree." 8.15, "Bulldog Drummond." The Vario Trio.

Abroad.
 Brussels II, 8, Operetta: "Der Juxbaron" (Kollo).

THURSDAY OCTOBER 17th.
 Nat., 8, "All Girls Together." 9, "Dinner is Served." Reg., Royal Philharmonic Society's Concert. Conductor: Sir Thomas Beecham, Bart.

Abroad.
 Kalundborg, 7, "The Messiah" (Handel).

NOVELTIES

"THE REVOLT AGAINST REASON," an English talk by Mr. Bertrand Russell (Kalundborg, Friday, October 11th, 6.30).

"Music and Wine," a programme devoted to music to be played when drinking wine (Frankfurt, Monday, 7.10 p.m.).

Concert by blind artists and pupils from the Copenhagen Royal Institute of the Blind (Kalundborg, Wednesday, 6.30).



CLASSICAL GEMS

LOVERS of classical music may pick upon the concert by the Beethoven String Quartet in F as the highlight of tomorrow's programmes. The Quartet will be heard at 6 p.m. on the Cologne wavelength. Rome gives two oratorios at 7.40 p.m. to-morrow: "Stabat Mater" (Pergolesi), and "Il giudizio universale" (Perosi).



OPERA

"CZAR AND CARPENTER," Lortzing's successful opera dealing with Peter the Great, is to be relayed by Vienna to-night from the State Opera at 6.25. This is the best-known of Lortzing's operas, and has been very popular in England since its *première* at the Gaiety in 1871, where it was produced as "Peter the Shipwright."

To-morrow evening at 8.45 Radio-Paris brings us two short operas based on Greek mythology: Massé's two-act



ROY HENDERSON, the famous bass, takes the part of a shepherd in Vaughan Williams' "Shepherds of the Delectable Mountains" on Monday (National, 8). This pastoral episode is based on Bunyan's "Pilgrim's Progress."



"ALL GIRLS TOGETHER"—a challenge to the Stanelli Stag Parties—will be featured on Thursday, when ten ladies will entertain listeners with a studio party. Above are Jenny Howard, Jean Melville (at the piano) and Mabel Constanduros, who are taking part.

"Galathée"—centring round the beautiful sea-nymph—and Gounod's "Philémon et Baucis," which shows the great French composer in lighter vein.

Wagner comes to the fore on Sunday with Brussels No. 2 relaying "Das Rheingold" from the Royal Flemish Opera, Antwerp, at 8 p.m. Lortzing's opera, "Hans Sachs," will be offered by Berlin (Funkstunde) at 7.10 on Monday. Another important operatic event of the week will be a festival performance of Gounod's "Faust," commemorating the composer's death on October 17th, 1893, to be relayed by Strasbourg at 8.15 on Thursday from Metz.



OPERETTA

THIS is an operetta week. Radio-Paris begins to-night with two one-act operettas: "Le Violoneux" (Offenbach)

and "Conchette" (Terrasse) at 8.45. Kalman's "Gipsy Princess"—ever popular—comes from Prague on Saturday at 7. A counter-attraction, also at 7, will be a classical operetta concert from Cologne consisting of songs "lifted" from three representative German works: "Gasparone" (Millöcker), "Fatinitza" (Suppé), and

"The Bird-Fancier" (Zeller).

A novelty in operetta will be Abraham's "Grand Hotel" which comes to the Warsaw microphone on Tuesday at 8. It is a pity that two other attractive operettas overlap on Wednesday. At 7 p.m. a radio adaptation of Planquette's "Mahomet's Paradise," with the amusing title, "The Thousand and Second Night," comes from Moscow No. 1, while at 8, Brussels No. 2 relays from the Exhibition Kollo's "Der Juxbaron." The composer is very popular in Germany.



"THE MESSIAH"

AN unabridged version of Handel's "Messiah" is to be broadcast from the Odd Fellows' Palace at Copenhagen on Thursday at 7, with Nikolai Malko conducting.

THE AUDITOR.

Deaf Aids

PART II.

AN ANALYSIS OF SOME OF THE PROBLEMS OF DESIGN

By N. W. McLACHLAN, D.Sc.

IN a previous article, published in the issue of Aug. 9th, the author discussed the progress which had been made in the scientific design of hearing aids. The present article deals further with the problem, describing in particular how a patient's hearing may be measured with accuracy

CONSIDERABLE interest, a goodly proportion of it being from friendly critics, was aroused by my article on this subject, published in *The Wireless World* of August 9th, 1935. It appears that the science of otology and the underlying principles of deaf-aid technique are at the moment in a state of flux. In fact the general situation, like that of television, is far from finality, and as a consequence there is bound to be a diversity of opinion on various matters relating to deaf-aids. Until further scientific data is available, there seems to be little likelihood of general agreement.

The article of August 9th was of a broad character, so it may be of interest

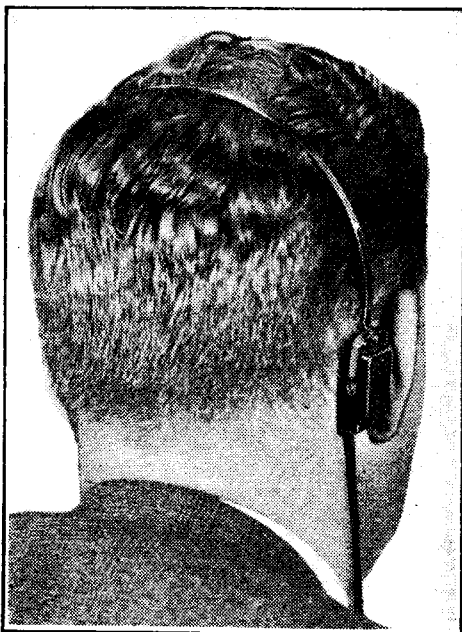

Fig. 1.—The Rein bone-conduction oscillator in position.

to consider the subject of deaf aids, which may intimately concern any one of us now or hereafter, in a little more detail.

When a telephone is held to the outer ear sound energy is conveyed to the inner ear (1) directly through the air via the ear drum, or (2) by bone conduction. The energy which reaches the inner ear in the first case is much greater than that in the second. Hearing by bone conduc-

Hearing tests being made with the Western Electric 2B audiometer

tion can be effected by using a special form of receiver, sometimes termed a bone-conduction oscillator. The vibrating element of this apparatus is pressed on the mastoid bone behind the ear, or on any other suitable bony projection of the skull. In principle the bone-conduction receiver is that of a telephone ear piece of very small dimensions, but the vibrating diaphragm is placed in contact with the skull, so the energy is transmitted directly instead of through the air. The lower threshold of audibility for bone conduction is illustrated in Fig. 2, and on the average it is 45 decibels above that for air-conduction as measured by the telephone receiver method described in the first article. This difference in level represents a power ratio of 32,000 to 1.

When Bone-conduction Helps

Nothing is gained by using a bone-conduction type of deaf aid unless the patient's air-conduction audiogram falls well below the bone-conduction threshold as given by Fig. 2. Even so, only in a few cases is any advantage obtained over an air-conduction type of aid. Bone-conduction deaf aids are frequently used by persons who wish the apparatus to be as unobtrusive as possible. In cases of severe deafness bone-conduction or air-conduction aids are seldom beneficial, since the inner ear is then usually defective, whilst the state of the bone is sometimes conducive to large transmission loss, little energy being conveyed to the inner ear.

In a normal ear, vibration of the ear drum is transmitted across the middle ear by a series of small bones to the inner ear. Here the vibrations are converted into nerve impulses which are transmitted to the brain by the auditory nerve. Deafness may be due to (1) swelling of the external ear or to stoppage of the canal by

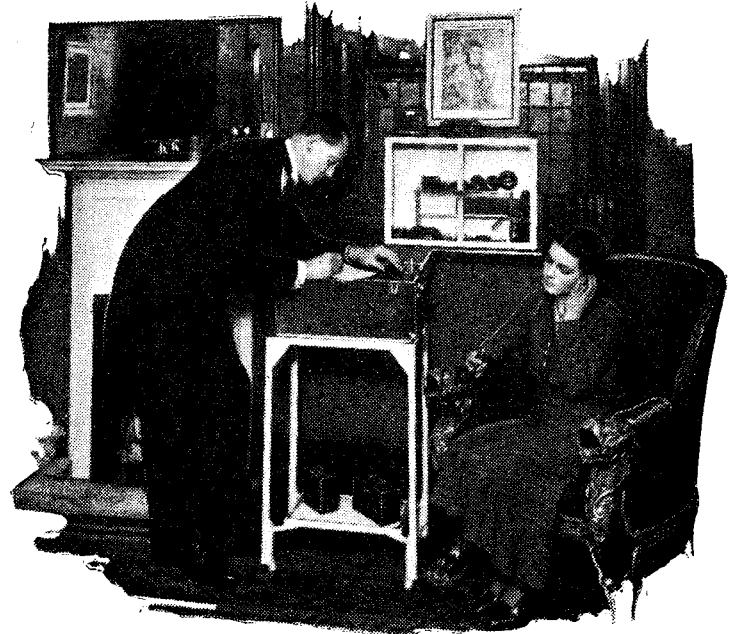

wax, (2) a defective middle ear, this being known as middle ear deafness, (3) a defective inner ear, auditory nerve or brain centre, this being known as inner ear or nerve deafness.

An analysis of the audiograms of 1,000 deaf persons showed that in the better ear of the two the threshold of audibility for air-conduction was most commonly from 45 to 70 decibels above the threshold for normal persons. Fifty-two per cent. of patients suffered from deafness which was maximal at the higher frequencies, 38 per cent. from deafness which was maximal at middle frequencies, 5 per cent. from deafness which was maximal at low frequencies, whilst 5 per cent. were almost uniformly deaf over the frequency range 64 to 8,192 cycles. Actual audiograms illustrating the first three forms of deafness are reproduced in Figs. 4, 5, 6.

Hitherto the view has been held that the frequency characteristic (showing the relationship between response and frequency) should be the inverse of the air-conduction audiogram. If the latter were

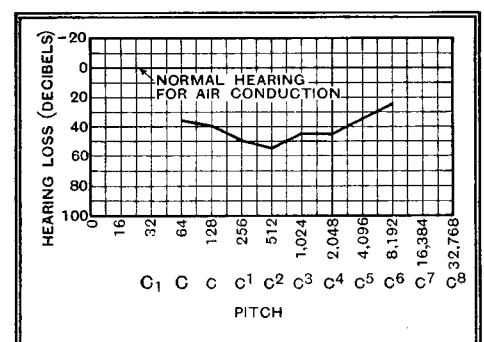

Fig. 2.—Bone-conduction threshold. Bone-conduction audiogram for normal person. This curve represents the threshold of audibility for bone conduction at various frequencies.

Deaf Aids—

that illustrated in Fig. 6, then the deaf-aid characteristic should be such that the net result is a uniform sound output level over the frequency range, i.e., the patient's audiogram taken with the aid in use should be a horizontal line. To obtain this line the microphone would have to be subjected to sound fields of equal intensity at the various test frequencies. In practice it is found that when a deaf aid is constructed on the above lines persons whose deafness is of the order 45 decibels below normal can hear quite well when the level is raised from 15 to 20 decibels. When the level is raised as much as 45 decibels the listener is usually distressed and immediately operates the volume control! One might be apt to conclude that the patient's hearing had been equalised over the frequency range used in the instrument, but at the moment there is no evidence available on this point. This brings us to the question of "loudness" and curves of equal "loudness level" for deaf ears.

Loudness Level

The term "loudness level" is really unsuitable to define what is actually intended. The family of curves shown in Fig. 7 are frequently termed curves of equal loudness level, but this is not an accurate description of them. Consider the curve marked 60 decibels. To obtain this curve

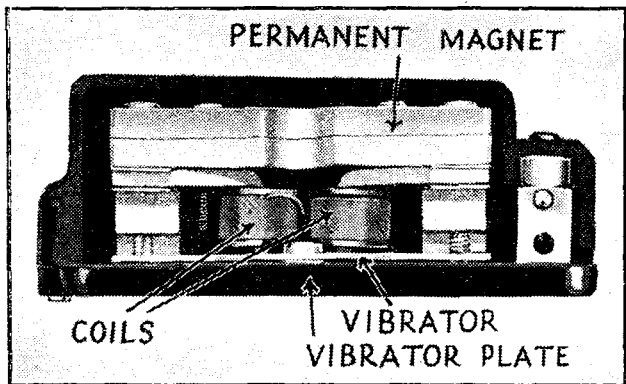

Fig. 3.—An enlarged view of the Rein bone-conduction oscillator, part of the casing has been removed.

a listener with normal hearing is seated in a room which is acoustically "dead." Using a calibrated high quality telephone receiver, he listens to a pure tone of 1,000 cycles sounded at a level 60 decibels above the lower threshold of audibility, which is taken to be that corresponding to a pressure of 200 microdynes per square centimetre. A tone of, say, 100 cycles is then sounded in place of the 1,000 cycles tone, and its level is adjusted until it seems to be as loud as the 1,000 cycles tone when the two are switched over. The level of the 100 cycles tone is found to be about 70 decibels above the threshold, when it appears to be as loud as a 1,000 cycles tone 60 decibels above the threshold. Points on the curve at other frequencies are found in like manner. Actually, therefore, the loudness is not specified in an absolute sense, but with reference to a

1,000-cycle tone whose level is known. Thus it is more accurate to say that the level of the 1,000-cycle tone is equal to that of the "reference tone level" of 60 decibels. This topic has been discussed more fully in "Noise," to which the reader is referred for further information. For shortness, "reference tone level" has been abbreviated to "reftone level," this taking the place of what one would colloquially term loudness level.

If the term loudness level were a suitable one, the perceived increase in loudness of a pure tone when raised from 40 to 50 decibels should be equal to that when the same tone is raised from 90 to 100

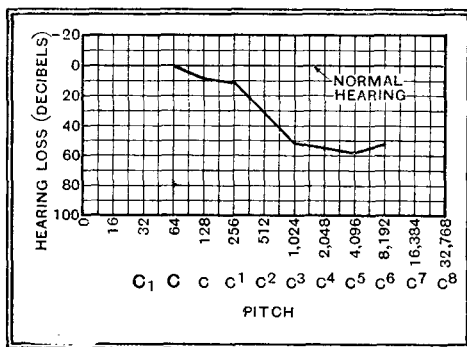

Fig. 4.—Air-conduction test. Audiogram illustrating deafness which is greatest at high frequencies, i.e., high tone deafness.

decibels above the datum of 200 microdynes per square centimetre. This, however, is far from being the case. In the first instance, the loudness increases 3.5 units, whereas in the second instance it increases 33 units or nearly ten times as much. The loudness units to which reference is made are such that 100 of them are equivalent to (i.e., seem equally loud as) a tone 100 decibels above the datum, the relationship between the two being shown by the curve in Fig. 8.² This experimental result serves to emphasise the fact that loudness is a sensation, but not a physical quantity which can be measured, like a length. By

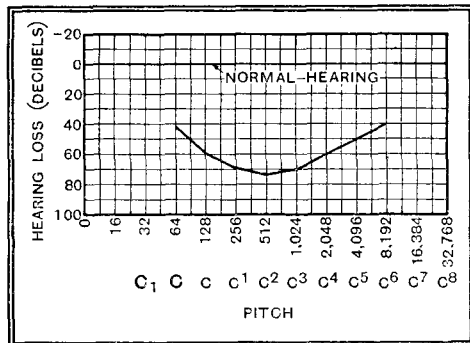

Fig. 5.—Air-conduction test. Audiogram illustrating deafness which is greatest at middle frequencies, i.e., middle tone deafness.

¹ "Noise, A Comprehensive Survey," Oxford University Press, 1935.
² Churcher, King and Davies, Journal I.E.E. 75,401, 1934.

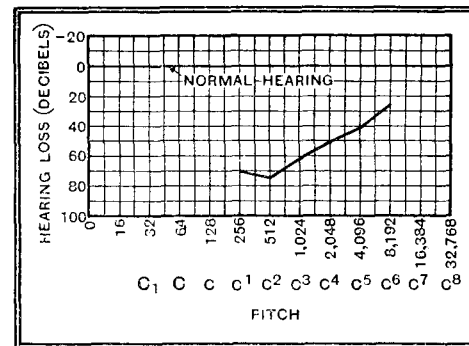

Fig. 6.—Air-conduction test. Audiogram illustrating deafness which is greatest at low frequencies, i.e., low tone deafness. The patient's deafness at frequencies below 256 cycles was outside the range of the audiometer and could not be measured.

using the nomenclature "reftone level," the difficulty respecting loudness level is removed.

The curves of equal reftone level shown in Fig. 7 are for normal ears. If the threshold of audibility of a deaf person is that shown in Fig. 5, it is not feasible to deduce his or her curves of equal reftone level by aid of those in Fig. 7. Assuming, however, that the threshold of audibility of a deaf person has been equalised by a suitable deaf aid to coincide with that marked 40 decibels in Fig. 7, one might be tempted to argue that the curves marked 50 db., 60 db., etc., in Fig. 7 were the reftone level curves of the deaf person when using the aid. But this step cannot be taken without experimental proof, and none is available yet. If a deaf aid is designed to give equalisation at the threshold of audibility, it may

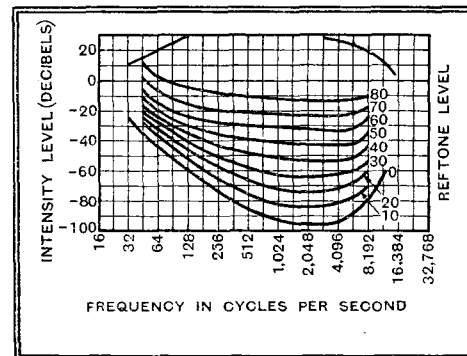

Fig. 7.—Curves showing that the loudness in the lower register increases much more quickly than that in the upper register for equal increments above the reftone level.

fail to do so at higher levels which are experienced during normal usage. This may explain, in part at least, why the output level from the telephone ear piece must be from 20 to 30 decibels below normal conversational level for comfortable audition, as already stated.

Let us consider the case of a person whose threshold of audibility by air-conduction is that shown by the curve of Fig. 5. To obtain equal audibility over the frequency range, the deaf-aid characteristic is taken to be the inverse of that illustrated in Fig. 5. If the amplification due to the aid be such that the level at 1,000 cycles is raised to 70 decibels to correspond to that of normal hearing, the frequencies above and below 1,000 cycles

Deaf Aids—

are magnified disproportionately. In fact the level at 8,192 cycles would be about 25 decibels below that experienced under normal conditions. Should the curves of equal reftone level for deaf persons—when using the aid—tend to become horizontal with increase in level, as is exemplified in Fig. 7 for normal ears, accentuation of the tones in the middle of the frequency range may be responsible for aural discomfort.

Adapting to the Patient

It is suggested, therefore, that a deaf aid may probably be adapted to a patient's condition more readily by follow-

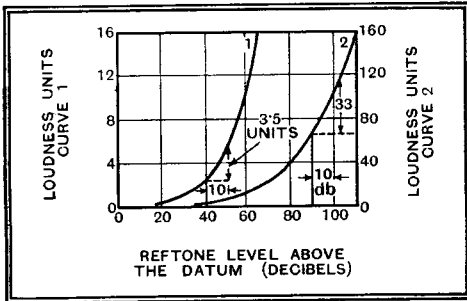

Fig. 8.—Curves illustrating the relationship between loudness and reftone level in decibels of an 800 cycle tone. Tests are the average of 34 persons.

ing the procedure given below. A 1,000 cycle reference tone is set to a comfortable level for the patient. His or her reftone level curve is then taken at this level, and the deaf aid designed so that in practice the reftone curve of the normal ear at the level of the 1,000 cycle tone is obtained. Valve amplifiers cannot be designed to have any frequency characteristic, so the accuracy of the matching will depend upon the shapes of the patient's reftone curve and that for the normal ear. The permissible degree of deviation or tolerance of the aid from the requisite curve, expressed in decibels, is a matter for experimental investigation.

If the sound output from the telephone receiver were to be increased appreciably beyond that for which the aid was intended, the correction circuit would have to be altered accordingly, just as the focus of field glasses has to be adjusted to suit the distance.

There is one important point which may be noted here, namely, the quality of the output from the aid. If there are serious resonances and alien frequencies, due to non-linear characteristics of the deaf-aid apparatus, then even to a person with normal hearing loud sounds may be disagreeable, as they certainly are when an ordinary telephone

conversation is abnormally loud. It is felt, therefore, that the distortion due to the aid should be as low as possible.

A series of reftone curves of persons suffering from various kinds of deafness would be of interest; nevertheless, it would probably be necessary to determine the curve for each patient before designing a suitable aid.

I wish to acknowledge my indebtedness to Dr. P. M. T. Kerridge for the audiograms of Figs. 4, 5, data relating thereto, and for discussions on the subject in general. I am indebted to Capt. L. V. K. Rein for the audiogram of Fig. 6.

BOOK REVIEW

The Electrical Encyclopedia. General Editor: S. G. Blaxland Stubbs, and six Associate Editors. (Vols. 4. Pp. 1400 + xii. Eight plates and 460 illustrations. The Waverley Book Co., Ltd., 96, Farringdon Street, London, E.C.4. Price £3 10s.)

THE difficulty about gaining technical information in these days is not the lack of it, but the superabundance. Even assuming that one has ready access to a good reference library, much time may be wasted in digging out the required facts.

The outstanding feature of this electrical encyclopædia is the accessibility of the information. The obviously laborious work of providing a really thorough system of cross-references, co-ordinating the work of the many contributing experts, has not been

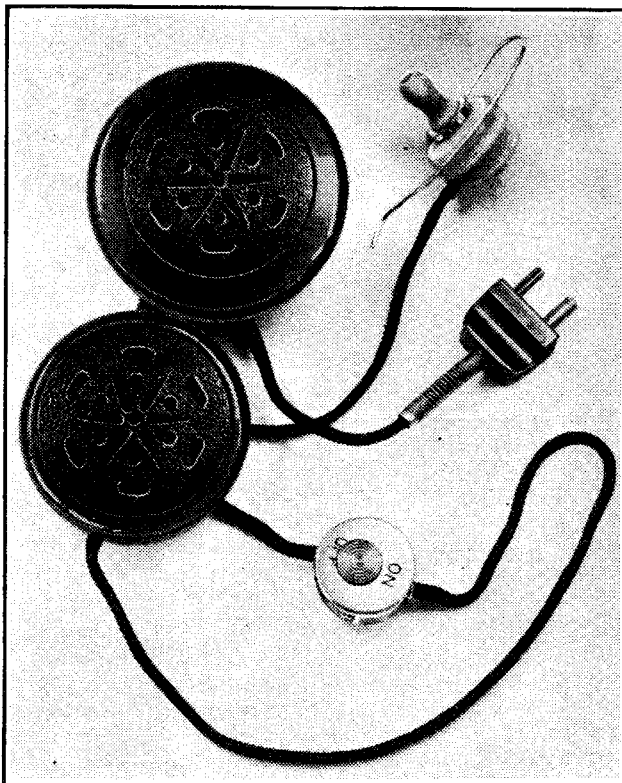

Fig. 9.—The Rein dual deaf-aid microphone equipment.

shirked. And in addition there are forty columns of excellently classified index to guide the reader to the various aspects of

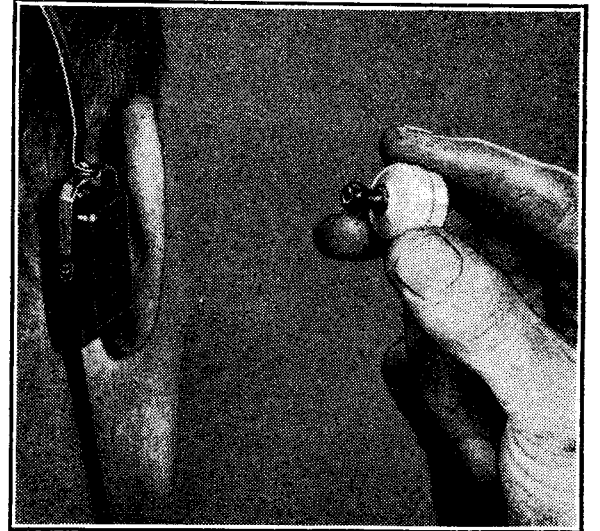

Fig. 10.—Showing relative sizes of the Rein bone-conduction oscillator and the deaf-aid telephone receiver.

a given subject. The only further aid that might be suggested would be references to more advanced books on the subjects.

The General Editor explains what the work does and does not do. Clearly the vast field of electricity cannot be covered in full detail in four, or, perhaps, even in forty, volumes. The work is not intended to give the specialist advanced information on his own subject, but more concise treatment of the many other branches of electrical work that are so closely inter-related. Thus, although radio is well represented under the able direction of Mr. S. O. Pearson, it is not suggested that these contributions are the sole or even the principal attraction to readers of *The Wireless World*. Such subjects as the slide rule, soldering, wiring regulations, thermostats, road traffic signalling, and modern lighting and heating are examples of subjects that any wireless enthusiast can turn to with interest.

Subjects such as large-scale engineering and modern telegraphy and telephony are only incidentally referred to, being the province of senior engineers and a few specialists. This leaves room for more adequate treatment of essentials.

The subjects are explained by acknowledged masters of clear technical exposition, and are on practical lines. It is regrettable, however, that in the important section on AC calculations, which receives special editorial mention, the reader should be confused at the start by the inductive component in a circuit being referred to correctly as reactance and also incorrectly as resistance. We also have the absurd term "AC current."

These are infrequent flaws, however, and the volumes can be confidently recommended. The illustrations are worthy of a final special word of praise.

Abbreviations to be used in the Civil Aeronautical Radio Service (Air Publication No. 1529).—Containing the complete "Q" code, miscellaneous abbreviations, and Service signals to be used by aircraft; many of these abbreviations are employed by marine and other telegraphic services. Pp. 46. Published by the Air Ministry, and obtainable from H.M. Stationery Office (London, Edinburgh, Manchester, Cardiff or Belfast), or through any bookseller. Price 1s., postage extra.

Variable Selectivity?

By "CATHODE RAY"

Certainly, But—

Let It Be Properly Designed

THE other day—some hundreds of millions of years ago, to be rather more precise—the configuration of the earth was markedly square-cut and sharp-edged. The stream of evolution has flowed continuously—except for minor setbacks in the form of earthquakes—in the direction of smoother and more rounded contours. It is too dangerous for a strictly technical and masculine writer to trace a similar tendency in more human modes during the comparatively momentary space of time of the last century, so I pass on rapidly to note the interesting fact that the development of radio has been in the reverse direction.

Primitive types of receiver (*circa* 1923) moved gently and gradually from one station to another. There was no danger of toppling suddenly over a sharp edge into

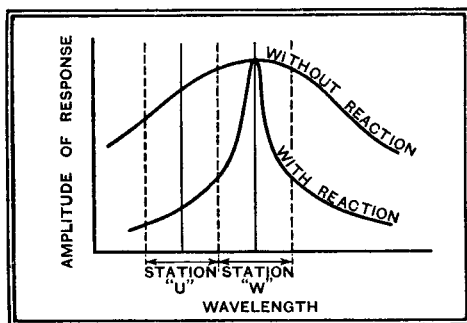

Fig. 1.—Comparative tuning curves of old-fashioned receiver, with and without use of reaction. The scale of the former curve is assumed to have been reduced by a volume control until the peaks coincide.

an abyss of silence. Unless two stations were *very* widely separated in wavelength, dial-turning did not quit the slopes of one before the next started to rise into view. And the exact tuned-in point was as difficult to determine as the precise summit of an East Anglian "hill"; anything within a dozen degrees or so was equally good.

At least, that was so in the absence of much reaction. Extreme reaction gave apparently sharp peaks of response to stations, so that exact tuning became necessary. But the difference was merely one of scale; the shapes of the peaks were the same; just compressed in the horizontal direction. It was impossible, with these simple tuning circuits, to have a level bit covering the desired station and then a sudden drop to exclude the next station. Fig. 1 shows the sort of thing, with and without reaction. "With" cuts out even an adjacent unwanted station "U" fairly considerably (there is another, more subtle, effect that helps it to do this much better than one would judge from the diagram), but also cuts down the fringes, corresponding to high audible notes, of the

wanted programme "W." Result: boomy reproduction, euphemistically termed "mellow." "Without" brings in all that is needed to give good, bright quality of reproduction, but also enough of the "U" stations to yield an incompatible mixture, for example, of Nazi oratory and "Soft Lights and Sweet Music."

That is the familiar dilemma of Selectivity *versus* Quality. We want both, but have to choose one, or a poor compromise.

Progress has resulted in more cliff-like outlines such as Fig. 2a. These can be got only by using a large number of tuned circuits—at least seven is usual in modern receivers—and it would be impossibly clumsy to vary all these by tuning condensers; hence the necessity for the superhet, which permits most of them to be fixed at the factory.

This looks like a complete solution to the problem, for the flat top can be designed just to cover a station nicely and then fall away very precipitously.

Interference-free Reception

And so it would be if the stations were spaced clear of one another in wavelength by even the thickness of a line. But, as even the youngest of us knows, they overlap; and freedom from interference is possible in only two circumstances: (1) When the wanted station is so much nearer or more powerful than any competitors that it literally shouts them down, or (2) when the response curve "gate" of Fig. 2a is made so narrow that unwanted stations of comparable or greater strength are tuned out, in which case it also excludes all except the whoofier parts of the programme, and the clashing of cymbals sounds as lively as dropping a codfish.

Most present-day receivers adopt a compromise curve that includes a workable showing of frequencies up to about 3,500 a second instead of the desirable 10,000 or more; wide enough to give a sound that the public associates quite readily with the original, but narrow enough to keep out all except very piratical competitors. To ease the situation farther a "tone control" is commonly provided to smooth off the upper notes still more and reduce the proportion of extraneous elements reaching the ear.

Granted that the wavelength situation is really an impossible one, there is yet a distinctly better attack than that just described. A fixed width of response can obviously be arranged to take advantage

of either of the two interference-free conditions mentioned above, but not both. If, however, the "gate" is under the control of the listener, he can, for each station and condition, narrow it until interference just ceases. In this way he is able to take advantage of favourable conditions, and, with any luck, to get something like good quality of reproduction. For many people favourable conditions occur most of the time, it being notorious that the majority of long-range sets are kept chained to the local stations. Then when there is an urgent need to hear the Bulgarian Test Match, through a barrage of fifty-kilowatts, the receiver with variable selectivity can be made as single-peaked as the best (or, rather, worst).

A well-designed variable-selectivity control is considerably superior to the common tone control, considered merely as a tone control. But it is vastly more; for the common tone control has no effect on true selectivity, but merely deadens the pain resulting from inadequate selectivity, except when it is used by the dance music fan to exaggerate the primitive negro constituent.

Something of the sort could be worked with the older sorts of sets by skilful simultaneous use of reaction and volume controls, but (1) it *did* require skill above

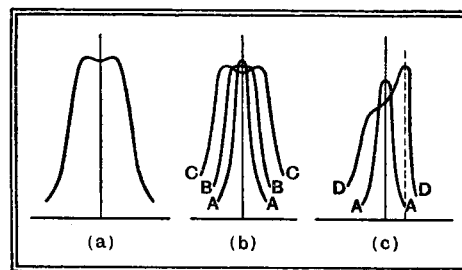

Fig. 2.—Tuning curve of a modern superhet compared with those of receivers having good and bad variable-selectivity controls.

that of at least 6,000,000 out of the present 7,000,000 licence holders, and (2) the result, when you got it, was much inferior to what can now be done by turning one knob.

The mere existence of variable selectivity in the specification does not guarantee all of these, or, in fact, any, merits. It has to be properly contrived and carried out. In Fig. 2b, if A is the tuning curve when the control is hard over in the selec-

Variable Selectivity—

tive position, it should develop into B and then C as it is moved the other way. What is very likely to happen is something like D in Fig. 2c. This has two gross defects that make the control an irritation instead of a pleasure. It entirely fails to give the desired good quality, for the response is very far from level; and if a station is tuned in with the control in the D position, and later a desire is felt for more selectivity, operation of the control merely causes the wanted station to disappear.

There are several possible methods of controlling selectivity; the root idea of most of them is variation of coupling between band-pass coils. Quite a fair result is obtainable (again if well carried out) by varying the distance between the IF transformer coils with some ganged mechanical contrivance. An alternative is to vary the

capacity of coupling condensers between the IF coils.

The H.M.V. "High-fidelity" radio-gramophone combines no fewer than five methods simultaneously, but of these only three really affect the selectivity, the others being tone compensators. The true methods are: movement of IF coils, variation of condensers coupling the radio-frequency preselector circuits, and switching damping resistances across IF coils.

If it were not for fear of Fig. 2c, I would say get variable selectivity, refuse all imitation, *exigez la marque*, etc. It is really a good thing. But Fig. 2c can be terribly exasperating. If many sets appear like that they will make the name of variable selectivity to become odious. And that would be a pity. So, manufacturers, it is important to study symmetry very closely.

Random Radiations

Guarantees

SOMETIMES I wonder just how much the guarantees given with certain sets are worth. Here is a case which seems to show that sometimes the "free" service that they promise merits not that particular adjective, but something of an altogether different and stronger nature. An expensive set was purchased in July last. Within three weeks a resistance burnt out. This was replaced, but blew up in a matter of hours. A third resistance behaved in the same way. The agent who had supplied the set agreed that it was deficient and that the fault was beyond him. It was, therefore, returned to the service department of the makers, who, after keeping it for six weeks, sent in a bill for thirty-three shillings, the amount being made up mainly by labour charges. This set has actually been in operation for little more than fifty hours since it was bought, and the customer not unnaturally feels that he has been "had."

I do think that important firms should deal with cases of this kind on their merits, making either no labour charge at all, or a very small one indeed, in cases where the customer has every reason to be thoroughly dissatisfied. Not to do so seems very bad policy, for naturally one sufferer tells another, and the particular make of set involved obtains a bad reputation (which may be quite undeserved) in the locality.

No Sympathy from Me

I NOTE with interest that the owner of a public address van, one of those horrors fitted with blaring loud speakers, was summoned the other day for "unlawfully using a noisy instrument, to wit, a loud speaker, for the purpose of selling goods." It appears that the van was using the streets to broadcast dance music, advertising announcements for certain goods being sandwiched in between the items. The owner was fined £1 and told by the Chairman of the Bench that he must not do it again. What a life we should have if every tradesman installed a giant loud speaker on his delivery van and bellowed through the streets the supreme advantages of buying his wares!

By "DIALLIST"

What is particularly interesting is that this summons was issued and the fine inflicted not under any modern Act or by-law, but under an old Metropolitan Police Act dating back nearly 100 years to 1839. We must thank our great-great-grandfathers for their foresight and forethought.

Loud Speakers Again

Meantime, a bylaw imposing a penalty of £5 on those who make nuisances of themselves with noisy loud speakers or gramophones has just come into force in the Borough of Paddington. It is framed on the lines of the Home Office model, and its one shortcoming is that no action can be taken unless at least three householders can be found to sign the notice served on the offender. In many cases the number of householders whose lives are made a perfect misery by some neighbour is less than three, and as matters stand nothing can then be done.

Still, the bylaw does seem to have been effective in places where it has already been in force for some time. In another London borough it has worked wonders, though no prosecutions have been necessary. Copies of the bylaw have been sent to offenders, and this has been sufficient to induce them to make more use of their manual volume controls.

A Quaint S O S

PROBABLY the queerest call ever sent out on police wireless in this country was one which summoned them the other day to the assistance of a London man whose pet monkey had gone mad. The police responded manfully to the call, a flying squad tearing to the assistance of the victim. The monkey, however, proved too fierce even for them to tackle, and a veterinary surgeon had to be called in to deal with the animal.

In the U.S.A.

Although there is a great deal of police wireless on the short waves, people in this country do not find it of the slightest interest. Matters are very different in the

United States, where manufacturers of all-wave receiving sets go out of their way to emphasise the fact that they will receive police radio calls. I suppose that in some of the big cities, where pitched battles between gangsters and things of that kind are not infrequent, there may be some sort of thrill in listening to police messages. But it is rather difficult to imagine what kind of person is induced to buy a receiving set largely because it will bring in red-hot news about crime and criminals. And in many other ways the mentality of English and American listeners is entirely different. We, I think, would soon be driven frantic by the scrappiness and the jazziness of many of the American broadcast programmes. They, on the other hand, would find many of the most popular broadcasts in this country boring in the extreme, largely on account of their length. One reason why American programmes are so much built up of very short items is that these are provided by advertisers who pay by the minute for their "time on the air." This is, I feel, one of the strongest arguments against the sponsoring of programmes.

Wiring Up the Country

THE rate at which the number of houses wired for electricity increases is really rather astonishing. The average increase of the last three years has been nearly 600,000 annually, and considerably more than half of the houses in this country now have either alternating or direct current supplies. The total number of houses in Great Britain is 11,336,376; of these 5,035,977 have AC, 1,037,729 have DC, and 5,262,670 are still unwired. Meantime the change from DC to AC in districts which still have the former goes forward rapidly. DC will probably linger on for a good many years in the more out-of-the-way places, but within a comparatively short time there should be few big towns in which houses have anything but standard AC at 230 volts.

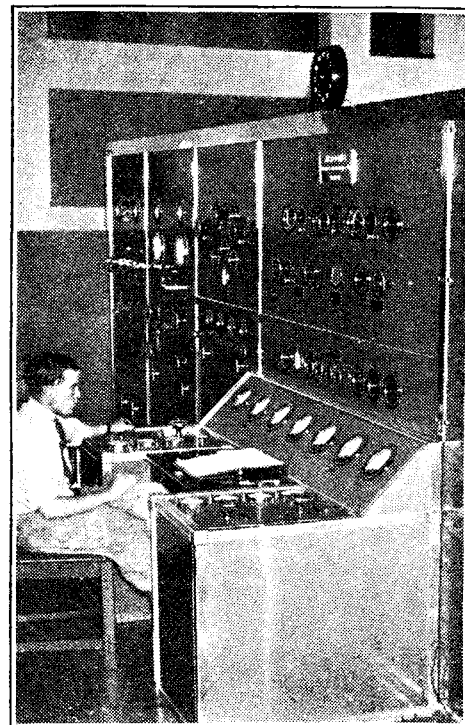

A new 10-kW. broadcasting station has been erected at Grahamstown, South Africa, by Marconi's Wireless Telegraph Co. The main transmitter control is seen in the picture.

BROADCAST BREVITIES

By Our

Special

Correspondent

A Red-Letter Sunday

NOW that Sundays are "set aside," as in the case of National Radio Sunday, to serve special purposes (why never Tuesdays?) October 27th should be National Acoustics Sunday.

It will be a red-letter day for all students of broadcast acoustics, for four new B.B.C. studios at Maida Vale, incorporating novel sound reflecting arrangements, will come into full service on that day.



Mr. RONALD COLLET NORMAN has been appointed Chairman of the B.B.C. for the remaining term of the present Charter.

Non-Parallel Walls

They are Nos. 2, 3, 4 and 5. Nos. 2 and 3, each of which has a floor area of 3,000 square feet and a volume of 60,000 cubic feet, are to be used for big orchestras and military bands. The walls and ceiling of No. 2 have been broken up by logarithmic re-entrants in such a manner as to avoid any parallel surfaces. No. 3 is of conventional design, the walls being composed of building board.

Experiments Now Proceeding

Much smaller are Nos. 4 and 5. Each has a floor area of about 1,300 sq. feet and a volume approximating to 25,000 cubic feet. No. 4 has irregular, smooth non-parallel walls.

All four studios must be regarded as experimental, the aim being to discover whether the non-parallel wall idea should be adopted as standard practice.

At present orchestral combinations of various sizes are being tried out on a closed circuit, and a careful record is being made of reverberation times to assist in the placing of microphones.

5-Metre Work at Daventry

NO one has connected 5-metre work with Empire broadcasting, but a friend who recently paid a flying visit to Daventry tells me that ultra-short waves are in regular use. Engineers at the top of the 500-foot masts now communicate with their colleagues on the ground by means of 5-metre transmitters carried on their backs.

The receiver stands on a tripod and incorporates a short steel rod aerial.

"Lining-Up" a New Aerial

Recently an engineer climbed the 500-foot ladder to the mast-head with his 5-metre transmitter. A colleague took a second set some two miles across country to Watling Street, and the third was on the ground beneath the Empire aeriels. By intercommunication the engineers were able to carry out quickly and easily an intricate job of "lining up" a new aerial which had to be fixed on a geographical bearing.

Henry Hall's Hour

HENRY HALL has put his cards on the table, and we now know that the "Guess Nights" will be known as "Henry Hall's Hour."

The highlights of these Saturday nightcaps will be performances by a glee club of thirty singers, the appearance of special star artists—paid guests—and what are described as Production Numbers.

A Rhythm Test

Production Numbers, which combine jazz with drama, are an excellent test of the listener's rhythmic sense. Let him try to continue dancing when the music ceases and the patten begins and see whether, when the music is resumed, he is still on the correct beat. This practice may also shed light on the mystery as to whether Henry Hall beats time from start to finish.

Biggest World Broadcast

NO fewer than twenty-eight countries will be participating in "Youth Sings Over the Frontiers"—the world-wide "hookup" which is to be broadcast between 5 and 6.30 on Sunday, October 27th.

Actually this feature, organised by the International Broadcasting Union, is more ambitious even than the Empire broadcasts at Christmas. All the singers will be taking part on their

native soil, and the focal point for this huge relay will be Brussels.

The Twenty-eight Countries

The countries participating are:—Germany, Switzerland, U.S.A., Finland, Lithuania, Italy, Spain, Yugoslavia, Austria, Belgium, Brazil, Denmark, France, Latvia, Sweden, Holland, Poland, Norway, Dutch East Indies, Siam, Rumania, Argentine, Czechoslovakia, Uruguay, Paraguay, Australia, South Africa, and Great Britain.

Another Good Word for the Crystal

ANYONE who doubts that the crystal set is coming into vogue again should ponder on this extract from the B.B.C. postbag:—

"I still stick to my ancient crystal set for two reasons: 1, The music is pure; 2, the 'phones keep my ears in a splendid position; they used to protrude . . ."

Selling Peace by Radio

PEACE is the product which is being advertised in a unique sponsored programme series now being put over the American Columbia Broadcasting System. Featuring eminent

ducts, but is footing the bill as an "institutional proposition," whatever that may mean.

Famous Names

Speakers in the broadcasts, which can be heard in Great Britain every Friday between 1.30 and 2 a.m. (G.M.T.) include Senator Borah, Senator Nye and Dr. Glenn Frank. Among the artists are Lucrezia Bori, Jascha Heifetz, George Gershwin, Richard Crooks and Lotte Lehmann. The writers include Fanny Hurst, John Erskine, and S. S. van Dine.

For Busy People

PROBABLY vast numbers of people are not able to listen with a clear conscience as early as 8 p.m. There are letters that ought to catch the night post, calls to be made, dogs to be promenaded, and half a dozen other odd jobs which make up the normal evening.

The B.B.C. now recognises that there is a large public that cannot settle down to enjoy the evening until between 9 and 10, and for them such features as the Monthly Revues have been introduced. Another such is



A DANUBIAN ECHO.—An informal photograph of the B.B.C.'s representatives in Budapest during the recent series of special programmes from the Hungarian capital. (Left to right) Miss Frances Clare, Mr. Eric Maschwitz and Mr. Val Gielgud.

statesmen, educational authorities, celebrated concert artists and world renowned dramatists, the programmes are being presented by World Peaceways, a non-profit organisation aiming at "realistic thinking about peace." The programme sponsor, a large drug manufacturing firm, is not advertising its pro-

"The Little Show," the first of which is featured to-night. This is a late night intimate cabaret feature.

To-night's cabaret includes Russell Johns, famous in the West End for his songs at the piano; Queenie Leonard, the revue and film star; and Rudi Grasl, "the living instrument."

UNBIASED

On or Off?

By

FREE GRID

DESIGNERS of present-day wireless receivers have a lot to learn from their hardy predecessors of a decade or more ago, as I have found to my cost.

It has been my invariable custom for many years to listen in bed to an extension loud speaker hung on the bedrail and to switch off by means of a push-button operating a relay connected to the receiver downstairs. This relay is of the type in which alternate jabs at the bell-push control turn the set on or off, and while it usually functions quite satisfactorily, it is liable at any moment to behave like a woman. If broadcasting is taking place at the time I switch off I know instantly, of course, whether or not the relay has functioned because the programme ceases. In the past the sudden cessation of mains hum when I switched off has kept me equally well-informed even if the station to which I was listening had closed down.

Unfortunately, my new set lacks this very necessary adjunct to the correct functioning of my relay system, it having a background of complete silence. Already this lack of forethought on the part of its designers has run me into considerable expense. The other night I switched off in the small hours of the morning, and owing to the absence of hum when the set was on I was at a complete loss to know whether the relay had functioned correctly or not. Consequently, I gave the push an extra jab for luck and went to sleep.

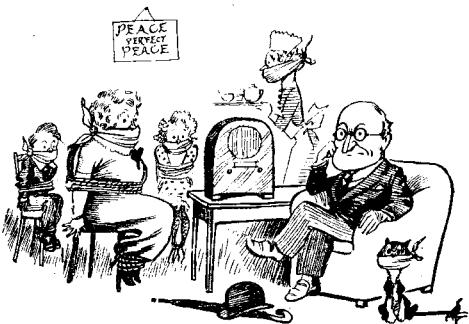

A background of complete silence.

On going downstairs next morning I found to my chagrin that the set was on. Evidently the relay *had* functioned the first time and my second jab at the push had switched the set on again. I am not complaining at the expense of the wasted power consumption, for at halfpenny a unit this is little enough in all conscience, but at the wearing out of my valves. Few people among those who thoughtlessly leave their sets on all night realise this point I think; it is the needless ageing of valves wherein lies the cost and not in the power consumption from the mains.

As it is, I am in a great dilemma as I never know whether the set is on or off. The worry is causing me to lose sleep and, the price of veronal being what it is, this is putting me to still further expense in the shape of sleeping tablets. Such is this so-called progress.

Screened Watch Wanted

I WONDER if any of you know where I can obtain a screened watch which is absolutely proof against being ruined by becoming magnetised.

In the old days, before the moving-coil loud speaker, troubles of this nature were comparatively rare. When, however, the moving-coil loud speaker was first invented by an ingenious watchmaker disguised as a wireless expert things were altered and the clockmaking trade began to prosper. At first, however, things weren't too bad, provided you remembered to take off your wrist watch before making any adjustment to the loud speaker.

With the use of stronger and stronger magnetic fields, however, things are becoming intolerable, and it is only necessary for you to go into a room containing a modern loud speaker for your watch to become magnetised. As a result of my original complaint, several watchmakers sent me samples of their so-called non-magnetic watches, but so far I have not received a single specimen which I have been unable to magnetise, although in some cases I have had a none-too-easy job, one watch in particular necessitating the insertion of its works in the case of a powerful solenoid for several hours before it finally yielded to treatment. What is wanted, of course, is some form of complete screening case.

Automatic Squeal Control

AMID the uncertainties of this uncertain world you can always count on America to produce some new and original ideas with the regularity of clockwork. It was probably this thought which prompted Virgil's famous remark: "Ex America semper aliquid novum."

The latest idea from that land of liberty is a development of the baby alarm which has so often been dealt with in this journal. As all readers from the first number—and their name is legion—will recollect, this consists of a microphone suspended over the child's cot and connected to the loud speaker downstairs so that if the child wakes, its cries are superimposed on the B.B.C. programme, thus

warning its doting mother of its need for succour.

In practice, as all family men know, the idea is perfectly useless for many reasons, the chief of which is that it is impossible to distinguish the child's cries from the noises of the crooners; and, in any case, no self-respecting woman is going to rise from her cocktail table in order to attend to the whims of infants. Apart from this, the yelpings of babies are usually quite powerful enough to dispense with the aid of microphones and amplifiers.

America has evidently fully realised this point, for their new improved baby alarm is entirely automatic in action, dispensing with the necessity of the mother leaving the card table or even being aware that the infant is in distress.

The instrument depends for its action on the new panacea for sleeplessness recently discovered in America. As all readers of the popular American magazines will be aware, medical circles in America are agog over this new wonder.

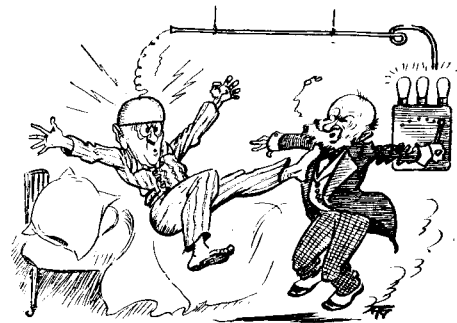

One or two unfortunate accidents.

An electrocutionist from one of the larger American gaols was struck by the extraordinary and instantaneous soporific effect of an electric current passing along the spine, and he conceived the idea that, administered in homœopathic doses, it would be of benefit to babies, bookies, and others whose consciences will not permit them to sleep at night.

After one or two unfortunate accidents due to over-dosage, he finally evolved his electric spine-massager, which can now be obtained at prices to suit all purses. For adults the current is under manual control, the seeker after sleep merely turning the rheostat slowly until he loses consciousness. In the case of babies, however, it was felt that manual control would not be suitable, as infantile curiosity might have disastrous results, and so an automatic system of control has been evolved.

This consists of a commendably ingenious relay circuit controlled by a microphone suspended over the child. The louder the screams of the child, the greater is the strength of the current, and this process continues until the screaming infant automatically extinguishes itself and peace reigns once more in the household. I have sent off a trial order for half a dozen, which I propose to distribute to my neighbours.

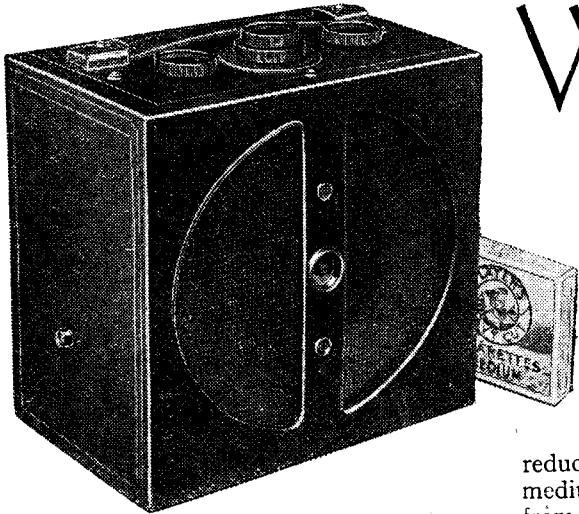

Wayfarer Portable

A Compact Receiver of Unusual Efficiency

FEATURES.—*Type.*—“Straight” circuit battery portable. *Circuit.*—Screen-grid HF amplifier—screen-grid detector with reaction—triode LF amplifier—pentode output valve. *Controls.*—(1) Tuning with concentric trimmer. (2) Reaction. (3) Wave-range and on-off switch. *Price.*—5 guineas. *Makers.*—London Electric Appliances, Ltd.

THE self-contained receiver makes an appeal to the imagination which increases progressively as the size of the set diminishes. With the latest miniature valves it is now possible to construct a set which will slip into a side-pocket; but the reduction of dimensions to these limits is not without its disadvantages, for not only must the voltage of HT batteries be reduced, but fewer hours of service from the LT battery must be accepted. Further, the efficiency of the frame aerial falls off, particularly on long waves, as its area is reduced.

In the “Wayfarer” portable a very happy compromise has been effected between these conflicting considerations. The dimensions are 9in. wide, 8½in. high, and 5½in. deep, so that it is very little larger than the average pressman’s camera. The 70-volt HT battery is of the same type and capacity as that used in the larger battery portables and transportables, and the 2-volt unspillable accumulator has a capacity of 10 ampere-hours. The weight of the complete receiver is nine pounds.

The reduction in size has, therefore, been made without any appreciable diminution of battery power, and the performance is quite definitely better than one would reasonably expect from so small a frame aerial. This is particularly so on the long-wave band which does not appear to have suffered the customary

reduction by comparison with the medium-wave performance. Judging from the strength of Droitwich in London there can be no doubt that this station will provide a reliable source of programmes in all but the remotest corners of the country. As the signal strength is just about equal to that from the two Brookmans Park transmitters, there is ample reserve of range to ensure that in travelling about the country a Regional programme will always be available as an alternative to Droitwich.

The first favourable impressions of the set were obtained inside a steel-framed building, and it was not until the set was taken outside that a

true estimate could be obtained of the high efficiency of the circuit. The controls comprise a combined wave-range and on-off switch, reaction control, and a double-tuning control which enables the frame aerial and HF coupling circuits to be accurately matched. Naturally, the full capabilities of the set can only be obtained with skilful handling of the con-

The dimensions of the chassis may be judged from the pentode output valve which is of the normal size. One of the screening cans has been cut away to show the HF valve.

The circuit is quite straightforward, and the efficiency of the set is due to close attention to detail in the design of individual components.

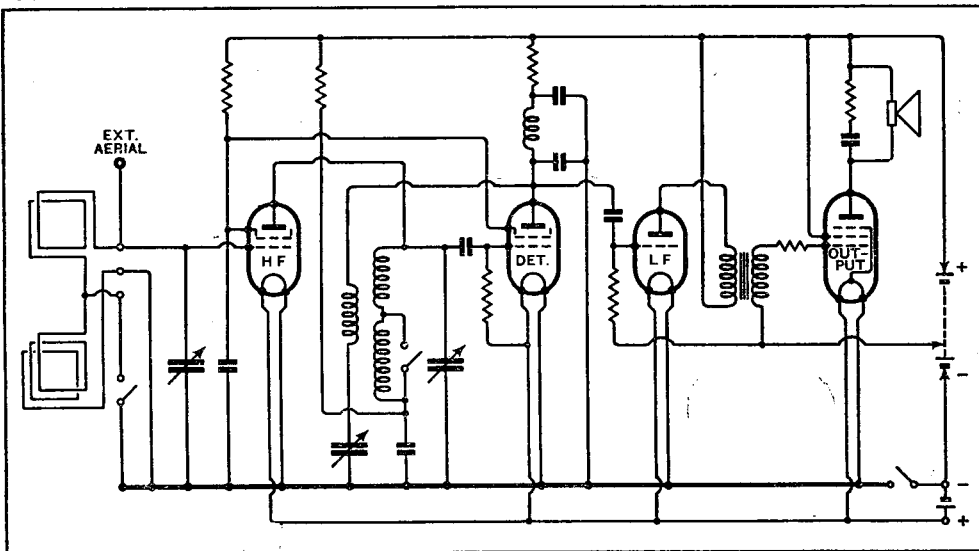
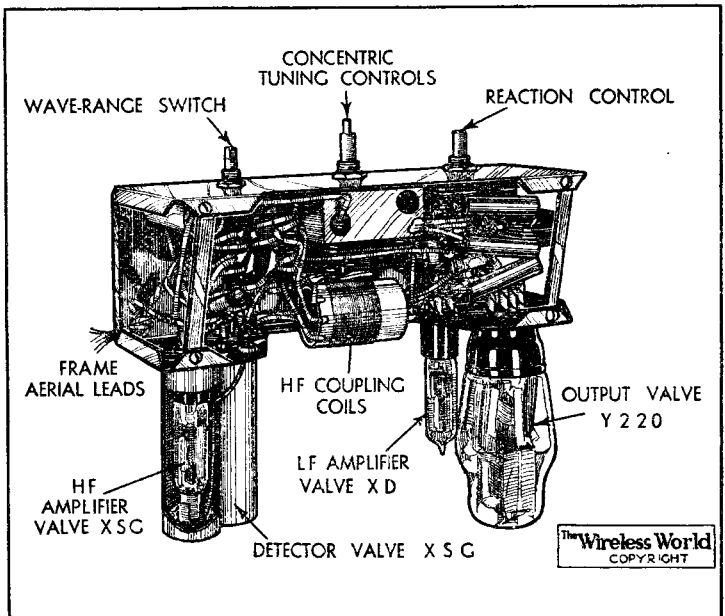

controls, but that is not to say that they are in any way critical, except perhaps at the bottom end of the medium-wave band. The most casual user could not fail to obtain satisfactory results from Droitwich and the Brookmans Park Regional station when using the set, say, in Central London, but some practice would be necessary before the reception of foreign stations, of which the set is undoubtedly capable after dark, could be satisfactorily accomplished. Tuned in the normal way without an earth connection the set is remarkably free from hand-capacity effects.

The loud speaker is of the moving-iron type, and is fitted with an elliptical diaphragm. It gives clear reproduction of speech, and its frequency range is sufficient to do justice to the majority of popular musical broadcasts, though naturally a bass response comparable with that of a moving coil is not to be expected.

The circuit employs four valves, three of which are of the miniature type, and

Wayfarer Portable—

the fourth, the output valve, is a standard pentode. Both the HF amplifier and the detector are of the screen-grid type and are completely enclosed by tubular metal shields. Tuned anode coupling is employed between these valves, and reaction is applied through the medium of the usual coupling coil and variable condenser from the anode of the detector valve. It is important in a set of this type to prevent leakage of HF into the LF stages, where it may eventually reach the loud speaker and so couple back to the frame aerial. Accordingly, in this set an efficient filter consisting of an HF choke with double by-pass condensers is incorporated in the detector stage. Resistance coupling is employed between the detector and the first LF amplifier, and a compact mu-metal transformer couples the triode to the pentode output valve. Fixed tone correction is provided by a resistance and condenser shunting the loud speaker windings.

On one side of the case a socket has been fitted for the attachment of an external aerial, which should not exceed fifteen feet in length as it is attached directly to the high-potential end of the frame, and might otherwise result in difficulty in bringing the two tuned circuits into resonance with each other.

Next Set Review—**AERODYNE
“AEROMAGIC”**

The replacement of the HT battery is a simple matter, as spring contacts pressing against studs on the chassis take the

place of the more usual wander plugs and flexible leads. A spare LT accumulator for use while the other is being charged is an accessory worth having, and may be obtained for 7s. 6d. A waterproof carrying case fitted with zip fasteners is also obtainable as an extra, and should relieve any self-consciousness the user may feel in carrying the set through the streets.

Distant Reception Notes

The New Toulouse Gets on the Air

THE French Regional Scheme originated by General Ferrié has been slow in developing, but now, after long delays, new stations are coming into operation with something like a rush. The Government high-powered transmitter at Toulouse was officially set to work on October 5th. It has taken over the service previously given by the 2 kilowatt Toulouse P.T.T. plant. Rated at 120 kilowatts, the new Toulouse station, which is situated just outside the town at Muret, works on a wavelength of 386.6 metres. This channel is shared at present with the 10 kilowatt Stalino and the 0.7 kilowatt Fredrickstad. Toulouse, however, will probably be powerful enough to swamp interference from its wavelength partners so far as reception in this country is concerned. It may be a difficult station to receive since its position in the wavelength tables is immediately between the 50-kilowatt Scottish Regional and the 120-kilowatt Leipzig.

The second Ferrié station to get under way is Nice, which is already testing. This is a 60-kilowatt plant. It will, I suppose, replace the 2-kilowatt Juan-les-Pins on 240.2 metres, since no other exclusive channel appears to be available. As Juan-les-Pins was often quite well heard over here I expect great things from the new station, which is thirty times as powerful. The only trouble is that it has to work in a part of the medium waveband which is badly congested and where wavelength wandering is rife. It has as neighbours Cork and various Swedish relays on the one side, and a mixed group consisting of Latvian, an Italian, and a Spanish station on the other. It remains to be seen whether its power will be sufficient to compel its neighbours in self-defence to keep at a respectful distance of at least 9 kilocycles.

I am afraid that the Portuguese station Parede, which has already suffered misfortune, will not be too happy about its wavelength partner on 291 metres now that Heilsberg has increased its power to 100 kilowatts. Even though the geographical separation of the two is considerable, the transmissions of the smaller station may be seriously interfered with in winter time except at very short range.

Are There Too Many High-power Stations?

This coming winter is bound to be a very interesting one, for it will give us a very good idea of how the Lucerne Plan is going to work out with the big stations operating at full power. During the summer a great many increases in power have taken place, and several more stations will move into the high-powered class between now and the end of the year. I am rather afraid that we shall find sideband splutter something of a nuisance during the darker months in cases where high-powered stations are working on adjacent wavelengths. It is becoming more and more important for stations to keep exactly to their wavelengths, and one notices with relief some improvement in this respect.

* * *

One wonders when Greece is going to come into line with the rest of Europe by introducing a broadcasting service. At present she has only one tiny station at Salonica which is rated at 1.25 kilowatts. Users of receiving apparatus in Greece must rely for their programmes almost entirely upon transmissions from other countries.

D. EXER.

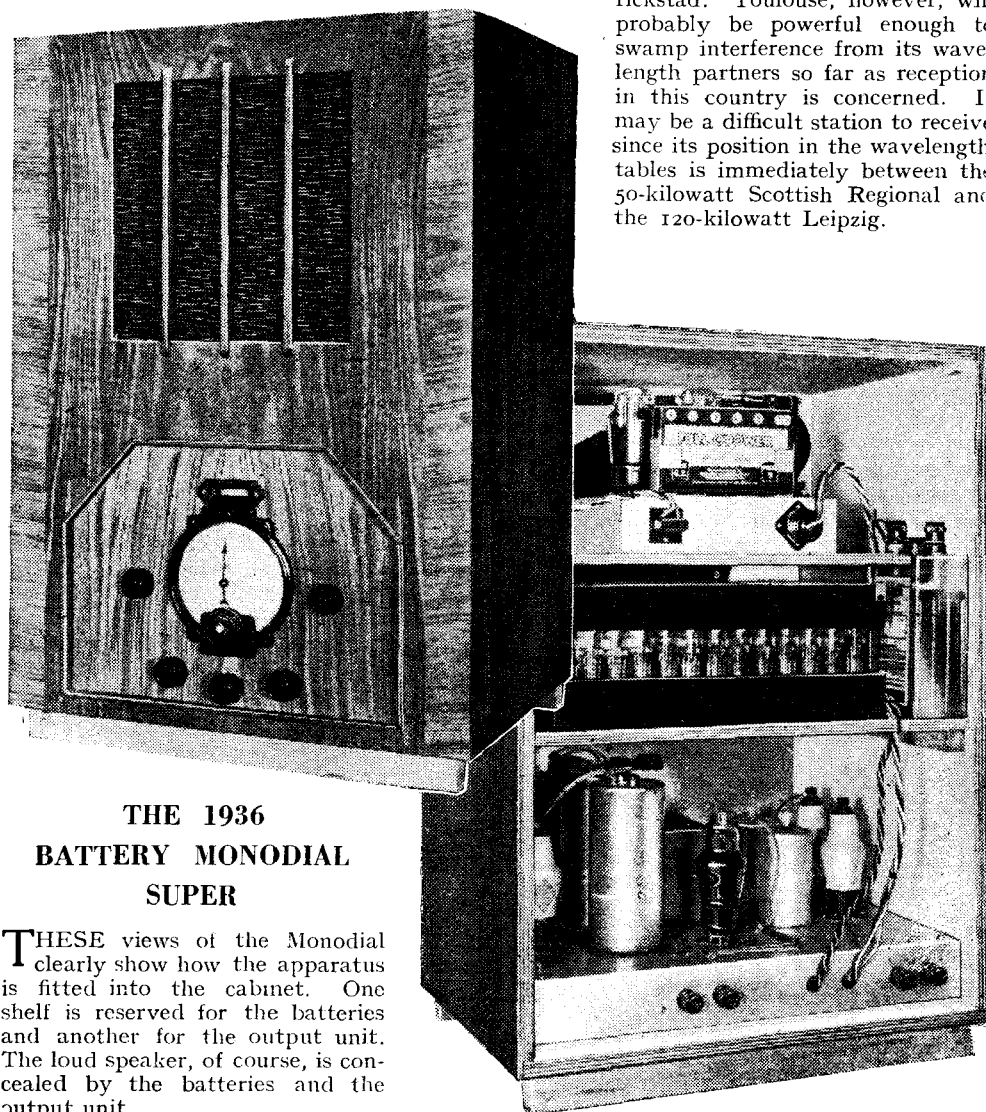

**THE 1936
BATTERY MONODIAL
SUPER**

THESE views of the Monodial clearly show how the apparatus is fitted into the cabinet. One shelf is reserved for the batteries and another for the output unit. The loud speaker, of course, is concealed by the batteries and the output unit.

The Wireless World

THE
PRACTICAL RADIO
JOURNAL
25th Year of Publication

No. 842.

FRIDAY, OCTOBER 18TH, 1935.

VOL. XXXVII. No. 16.

Proprietors: ILIFFE & SONS LTD.

Editor:
HUGH S. POCOCK.

Editorial,
Advertising and Publishing Offices:
DORSET HOUSE, STAMFORD STREET,
LONDON, S.E.1.

Telephone: Hop 3333 (50 lines).
Telegrams: "Ethaworld, Sedist, London."

COVENTRY: Hertford Street.
Telegrams: "Autocar, Coventry." Telephone: 5270 Coventry.

BIRMINGHAM:
Guildhall Buildings, Navigation Street, 2.
Telegrams: "Autopress, Birmingham." Telephone: 2971 Midland (4 lines).

MANCHESTER: 260, Deansgate, 3.
Telegrams: "Iliffe, Manchester." Telephone: Blackfriars 4412 (4 lines).

GLASGOW: 26B, Renfield Street, C.2.
Telegrams: "Iliffe, Glasgow." Telephone: Central 4857.

PUBLISHED WEEKLY. ENTERED AS SECOND
CLASS MATTER AT NEW YORK, N.Y.

Subscription Rates:
Home, £1 1s. 8d.; Canada, £1 1s. 8d.; other
countries, £1 3s. 10d. per annum.

As many of the circuits and apparatus described in these pages are covered by patents, readers are advised, before making use of them, to satisfy themselves that they would not be infringing patents.

CONTENTS

	Page
Editorial Comment	411
Bringing an Old Set Up to date ..	412
Making a Choice	415
The Second-hand Set—Circuit and Performance	416
A New Tuning Indicator	418
Current Topics	419
Aerodyne "Aeromagic" Receiver	420
Broadcast Brevities	423
Revalving	424
Listeners' Guide for the Week ..	426
Sets of Yesterday	428
Four Cardinal Points	431
Random Radiations	432
Letters to the Editor	433
Unbiased	434

EDITORIAL COMMENT

The Second-hand Set

Special Articles this Week

IN this issue we include articles dealing with the second-hand set. The contributions are intended to provide a guide to the choice of second-hand sets, and advice on what should be done to recondition them or to modify them where improvements can be effected by so doing.

As we have explained in previous issues, we believe that *The Wireless World* will be providing a valuable service if it becomes the recognised medium for the "sale" or "purchase" of the second-hand set.

There are many people continuing to use the same receiver that they have had for years, simply because there is at present no convenient method of disposing of it.

Until a satisfactory second-hand market was created for cars the owner retained his car so long as it would go. The present prosperity of the car industry is due in considerable measure to the ease with which second-hand cars can now be disposed of to make way for new ones.

Automatic Tuning

Important Technical Progress

THERE will always be those who oppose any concession to the laziness of listeners just as the hard boiled motorist said that synchro-mesh would take all the joy out of motoring. Instead it has resulted in obtaining *better performance* from the car as well as making driving easier.

The same may be said for the new automatic tuning devices which are now making their appearance. Better quality of reproduction has emerged from a device which was designed primarily to simplify tuning.

Both the Murphy 28 Receiver recently reviewed and the Aerodyne "Aeromagic" described elsewhere in this issue, set out to achieve the same end and reach their goal by technically divergent routes.

At a time when design showed signs of getting in a rut it is gratifying to find these proofs of active originality among some of our manufacturers and we hope that their example will be followed in other directions to the benefit of the listener and the wireless industry as a whole.

Emergency Broadcasting

If Power Stations Were Bombed?

AN interesting point is raised by a correspondent in a letter published in this issue. He reminds us that wireless sets, to an ever increasing extent, are dependent upon the house electric supply for their operation. The B.B.C., it is explained, take precautions in the matter of source of supply and can generate their own electricity so as to maintain transmissions even if total failure of the normal source of electricity should occur.

Strikes, riot or civil commotion may be the cause of a cessation of the proper working of electrical power stations and the possibility of their destruction by bombing in time of war cannot be ignored.

It is in just such extreme emergencies as these that the greatest need for broadcasting to disseminate news and allay panic would be felt, but as matters stand at present the transmissions would then go out to silent sets in a large proportion of our homes.

Our correspondent suggests that it would be a good thing to encourage every mains set owner to acquire, in addition, a crystal set to be regarded as a stand-by in case of emergency.

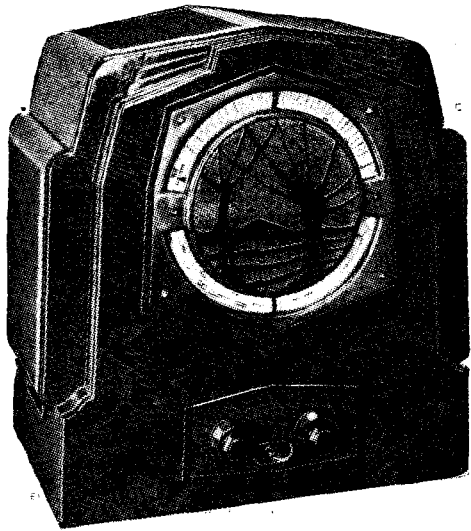

Bringing an Old Set

Adding AVC to the Ekco SH25 Superheterodyne

Automatic volume control at once occurs to one as an obvious advantage of the newer receivers, and if much distant listening be done its fitment is well worth while, for it greatly reduces the effects of fading. Another alteration which appears attractive is to change the two-valve frequency-changer almost invariably employed in the older superheterodynes for a modern single-valve type embodying a

heptode, octode, triode-hexode, or triode-pentode. Unless some advantage can be derived indirectly from the change, however, this is one which is not likely to lead to any appreciable improvement in performance. The chief advantages of the new frequency-changers over the old are that they use one valve instead of two and that the circuit employed is some-

MANY of the older receivers, after several years' hard work, are still capable of a high standard of performance and show up surprisingly well in a comparison with the latest designs. This fact is unexpected by most people, for there can be no question that development in receiver technique has been proceeding rapidly, and it is natural to expect that the consequence of this would be a big improvement in the performance of the more recent designs. When one considers the case in more detail, however, one finds that only a portion of the development has lain in that field of technical improvement which is reflected in a higher standard of performance. As often as not the aim of the set maker's laboratory has been to obtain the same performance at lower cost. This is by no means an aim to be despised, and the productions which result from intensive action on these lines are often a real achievement and reflect great credit to their designers. It should be realised, however, that their merit lies in their better performance for a given cost as compared with an older set, and not necessarily in any ability to give a better electrical performance judged by absolute standards and taking no account of expenditure.

Possible Modifications

It follows from this that a set of a few years ago will often still give as good an electrical performance as a new set of the same general type, but the new set will cost less than the old one did originally. A new set costing as much as the old one will, of course, have a generally better performance. There are, however, a number of genuine technical improvements which are now incorporated in all but the cheapest sets and which are likely to be absent from the older ones. In some cases they can readily be added to an old set, and where this is possible the question of whether it is worth while to make the addition is one which is worth careful consideration.

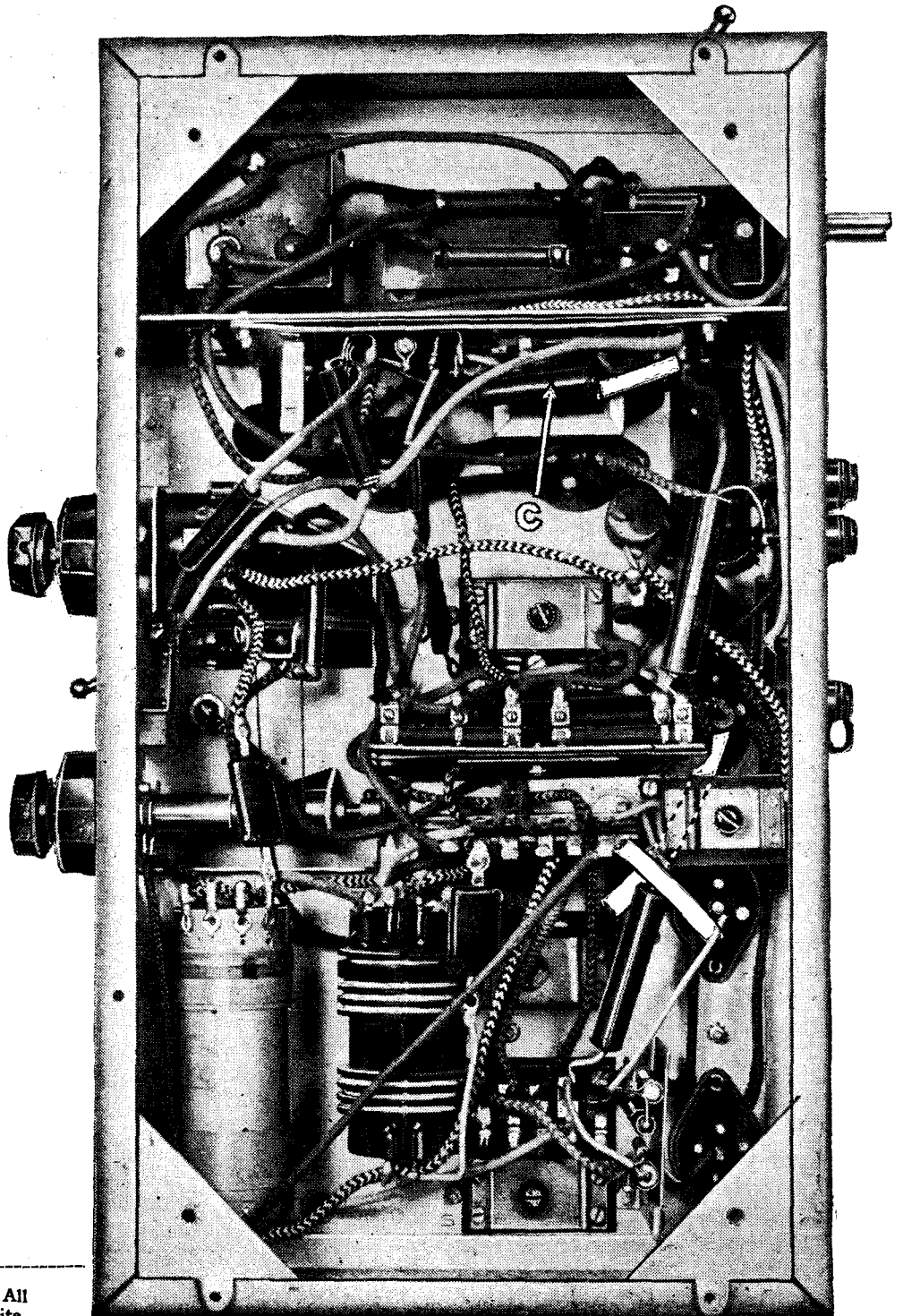

Fig. 1.—An underside view of the receiver. All wires which must be removed are shown white.

Up to Date

what simpler. Both these factors mean lower cost, and hence they are almost invariably used nowadays. The performance, however, is very little better. It will only pay to alter the frequency-changer if it be advisable or necessary to permit other modifications which do lead to a better performance or more convenient operation. A case in point would be the conversion of a DC set to AC/DC operation. In this case new valves throughout would be needed, and as their constants would almost inevitably be different from the DC ones originally used, changes in the circuit constants would probably be needed to permit correct operation. The substitution of a single-valve frequency-changer would then only involve a little more alteration,

and it would result in the saving of a valve, so that the alteration would prove financially advantageous.

AVC

The most important technical improvement of recent years which can be added to an old set is undoubtedly AVC, and it is fortunate that it is usually possible to make the alterations very easily. Although there are very many different ways of obtaining AVC there is one which stands out over all others for its suitability to the requirements of the older type of sets.

Those sets almost invariably employed a grid detector, and it is readily possible to connect this so that it acts also as an

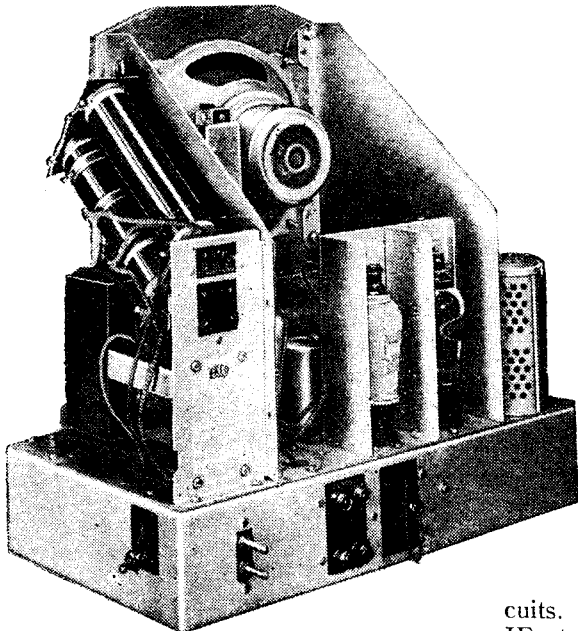

A rear view of the receiver removed from its cabinet.

additional IF stage for AVC purposes, and the AVC rectifier can then be fed from its anode circuit. A form of amplified AVC can thus be obtained with very little alteration to the receiver.

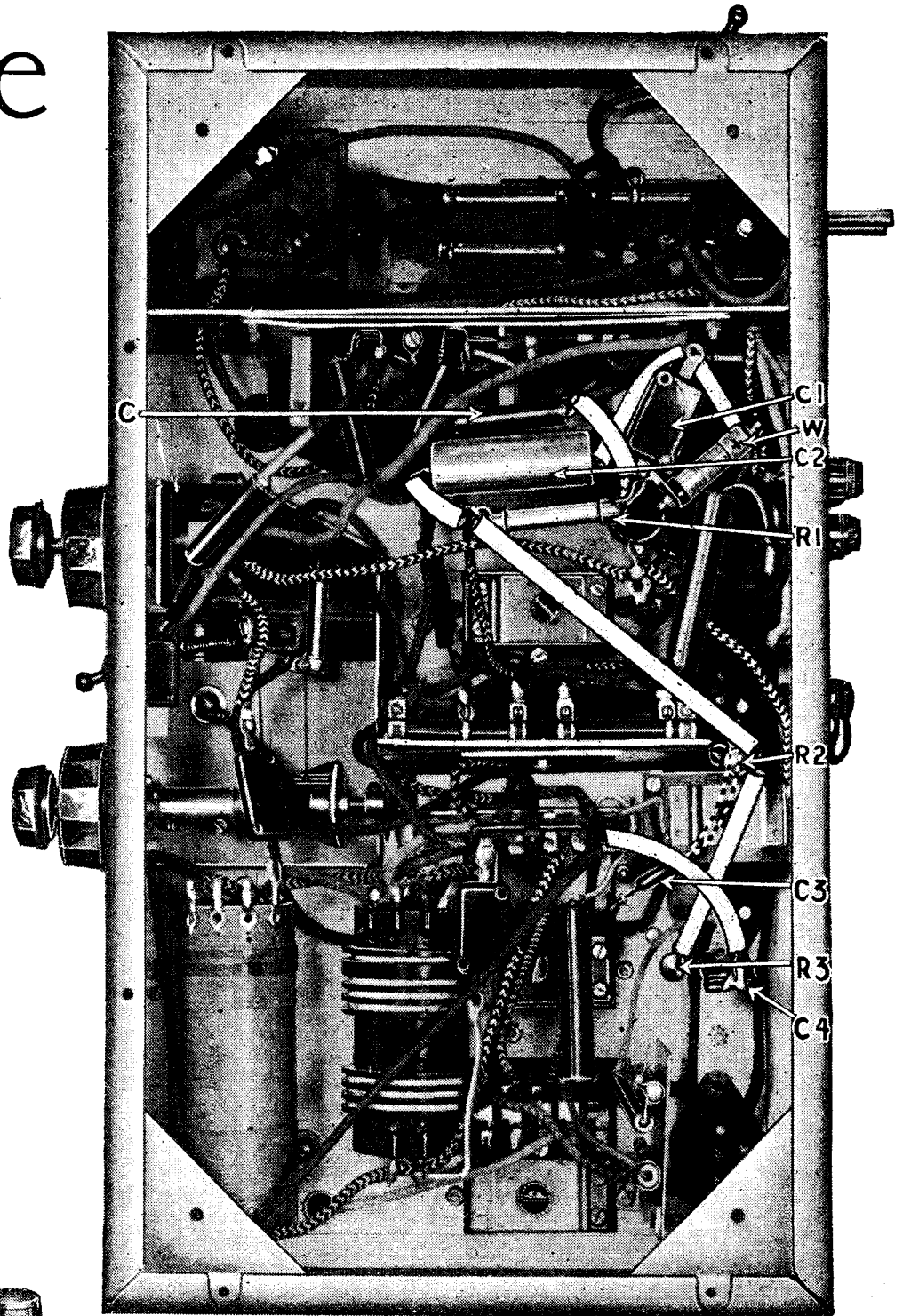

Fig. 2.—This view of the set shows the new components and wiring. One end of R2 is joined to the AVC line and the other to the grid pin of the IF valve to which C3 is also connected.

The changes involved are best described by a practical example, and for this purpose the Ekco SH25 receiver will be used. This is a DC mains set having a two-valve frequency-changer preceded by a pair of coupled tuned circuits. A single IF stage is used with two IF transformers each containing two coupled circuits, and a grid detector feeds a pentode output valve through a resistance-fed transformer. An HF choke is connected in the detector anode circuit with the usual by-pass condenser to the cathode circuit.

This condenser C has a value of 0.01

mfd., so that the detector normally gives very little amplification at the intermediate frequency. If the earthy end of this condenser be disconnected and re-joined to the cathode circuit through a 0.0003 mfd. condenser, however, the detector will give a considerable IF gain and nearly the whole of this amplified voltage will appear across the 0.0003 mfd. condenser C1. The connection of a Westector across this condenser results in the IF potentials being rectified, with the result that a steady potential appears across C1, which is nearly proportional to the IF voltage. No load resistance is needed with the Westector, for its internal resistance in the "non-conductive"

Bringing an Old Set Up to Date—

direction is not infinite, and it can consequently act as its own load resistance. In this simple way it is possible to obtain a steady potential of quite large value which is nearly proportional to the detector input, and it only remains to feed this as grid bias for the early valves to an efficient AVC system to be obtained.

The precise method of applying the bias varies in individual cases and depends somewhat upon the accessibility of the various points concerned.

In this case the bias is most easily applied through high resistances directly to the grids of the controlled valves. It is necessary, therefore, to remove the lead to the grid of the first detector and to insert in its place a 0.0001 mfd. condenser C₄; the grid lead of the IF valve must also be removed and a 0.0001 mfd. condenser C₃ inserted in its place. One end of a 1 megohm resistance R₃ must now be joined to the first detector grid by a very short lead; one end of another resistance R₂ of 2 megohms must similarly be joined to the IF valve grid. The free ends of these two resistances are joined together and taken through a 0.1 megohm resistance R₁ to the junction of the 0.01 mfd. condenser referred to previously with the Westector and C₁. The alterations are completed by connecting a 0.1 mfd. condenser C₂ from the AVC line to the earthy end of C₁.

The alterations in the case of the Ekco SH25 receiver will be clear from a study of the photographs illustrating this article. In Fig. 1 the wires which must be removed from the original receiver in order to carry out the alterations are clearly shown in white. Figs. 2 and 3 show the extra components and their connections, the wiring being again shown in white for clarity. The components needed to effect the change are few in number and consist of

- 1 Resistance, 0.1 megohm, R₁.
- 1 Resistance, 1 megohm, R₃.
- 1 Resistance, 2 megohms, R₂.
- 2 Fixed condensers, 0.0001 mfd., C₃, C₄.
- 1 Fixed condenser, 0.0003 mfd., C₁.
- 1 Fixed condenser, 0.1 mfd., C₂.
- 1 Westector, Type WX6.

Owing to the manner in which the changes are carried out neither the

trimming of the IF circuits nor the ganging should need adjustment. The last IF circuit is the only one which can be appreciably affected by the changes, and here the circuit is so heavily damped by

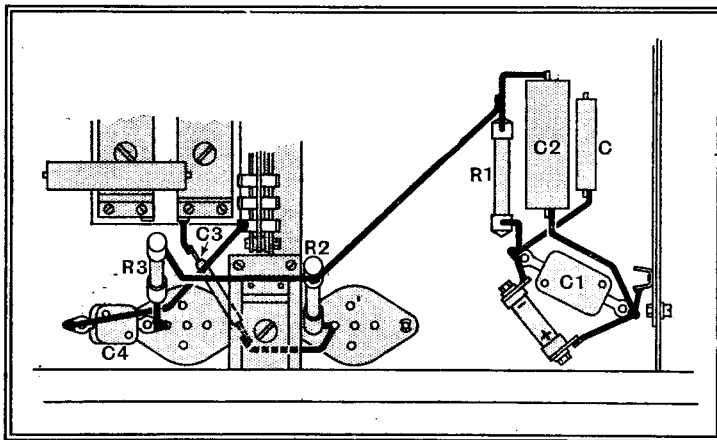

Fig. 3.—This drawing shows more clearly than the photographs the connections to the controlled valves.

the detector that the effect of any small degree of misalignment is negligible. Although the alterations themselves should not necessitate any readjustment of the circuits, it is certainly advisable to retrim the set, for the compression type trimmers invariably used in all older receivers do tend to change their capacity after a time, and an improved performance usually follows their correct adjustment. The procedure to be adopted is quite straightforward and has been described many times in *The Wireless World*.

Some doubts may be felt on two points arising out of the alterations. The first is in relation to the volume control. This consists of a variable resistance which is so connected that it simultaneously increases the bias on the IF valve and reduces the aerial input to the set. In addition, a local-distance switch is connected to throw a resistance across one of the coils in the first IF transformer and so

reduce the gain and flatten the tuning for local reception. When AVC is used it is the usual practice to include a post-detector volume control, but it would not be safe to do so in this case, for on a very strong signal there would be a risk of the grid detector being overloaded. It has been found experimentally that the original volume control still gives the best results and it is accordingly advisable to retain it. Partly in consequence of this there is a considerable difference in the volume between distant and local stations for a given setting of the volume control, but the chief advantage of AVC, the reduction of fading, is retained.

The second point upon which doubt may be felt lies in the first detector. This valve is not of the variable- μ type, and yet AVC is applied to it! Actually, of course, any valve is "variable- μ ," for in every valve the mutual conductance changes with the grid bias applied to it. The so-called variable- μ valves are specially designed to give a smooth variation of mutual conductance over a wide range with a large variation in grid bias, so that a large signal can be handled without distortion. On small signals an ordinary valve will give similar results with less grid bias.

The effect of using an ordinary screen-grid valve for the first detector is thus the same as using a variable- μ type with higher AVC amplification and a partial control only on the IF valve. This is on weak signals. On strong signals, distortion would undoubtedly occur if it were not for the particular form of volume control incorporated which permits the signal input to be reduced.

The performance of the receiver after the alterations had been made was found fully to justify these theoretical expectations and was in every way fully equal to that of the original unmodified set with the added advantage, of course, of the improvement brought about through the reduction of fading.

CATHODE-RAY TUBES

IN cathode-ray television the size of the received picture is limited, in the first place by the dimensions of the tube, and in the second place by the fact that the intensity of light available on the fluorescent screen is not usually sufficient to justify further enlargement. Any gain in size produced by the use of a magnifying lens is in general more than offset by a corresponding loss of definition.

Von Ardenne, however, has suggested that it may be worth while to produce

tubes in the form of a straight cylinder, replacing the usual flared end by the depressed shape shown in the figure. The concave end B then forms with the convex lens L an optical system which throws an enlarged picture on the viewing screen S.

The main object is to reduce the initial cost of the tube. The usual "flared" bulb, particularly in the case of highly exhausted tubes, leads to a high proportion of "rejects." On the other hand, a cylinder with a concave end is inherently stronger in design. The tube is made as short as possible consistent with the permissible heating of the screen.

By way of example, the tube may be 20 cm. long, with a diameter of 5 cm. Using a fluorescent screen having an area of approximately 4×3 cm., the inventor states that he is able to produce clear enlargements up to ten times that size on the viewing screen.

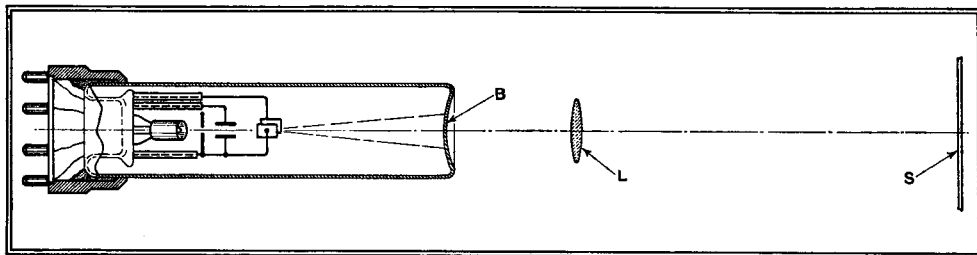

CHEAPER TELEVISION? A small cathode-ray tube designed to project an enlarged image.

MAKING A CHOICE

Points to be Remembered When Selecting a Second-hand Set

IN other article appearing in this issue the pros and cons of various circuit arrangements as they affect buyers of second-hand sets are discussed at length, and, moreover, information is given as to what kind of circuit is likely to be found in receivers of the last few years. Another article explains the true inwardness of the four cardinal virtues on which every set should be judged; it cannot be too highly stressed that these qualities are fundamental, and that, compared with them, "trimmings" are of merely secondary importance.

Apart from these general principles, certain other details deserve attention. To start at the beginning, it is opportune to warn the novice that he will find a regrettable lack of uniformity in some quarters with regard to the nomenclature of the sets offered to him. For instance, the "straight" HF-det.-LF three-valve receiver is variously described as "screen grid," "band-pass," and "straight three." But others, for some obscure reason, reserve the expression "straight" for det.-LF sets without an HF stage.

AC, DC, or Battery ?

The first consideration of the buyer must obviously be the suitability of the set for the form of electrical supply that is available; that is a truism, but it is well to remember that, besides the questions of nature of supply and voltage, periodicity of AC must also be taken into account; a 25-cycle set will work on 50 cycles, but the converse does not hold true.

With regard to circuit arrangements those who have read the other articles in this issue will already have reached the

conclusion that, broadly speaking, the superhet is the only thing to choose if one regards range and selectivity as of primary importance. True, there are a few sets with multi-stage HF amplifiers which put up a remarkably good performance, but few of them seem to appear on the second-hand market. The HF-det.-LF set is mainly chosen for short- or medium-range work, with occasional foreign-station reception. For purely local-station work, particularly as a stand-by set, we are apt

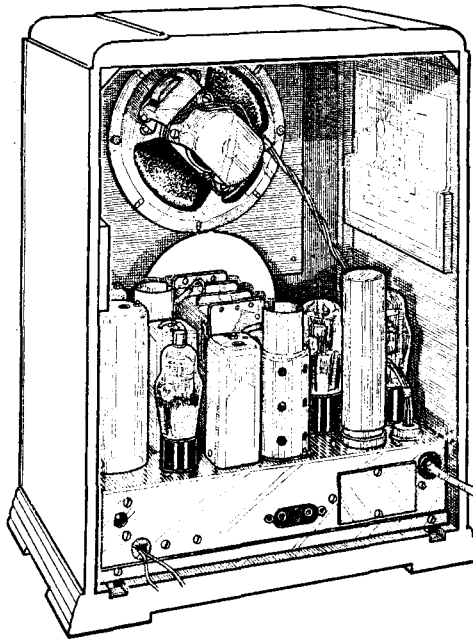

If circuit diagrams and instruction cards were always fixed to the receiver in this way, they would not so often be lost.

to forget the claims of the humble detector-LF receiver; with suitable means of limiting signal input from the aerial, and a trace of reaction to improve selectivity, it is generally capable of making a good showing even in the vicinity of twin-wave transmitters.

Whatever kind of set is chosen, it should be borne in mind that its behaviour from the point of view of selectivity—and to some extent of quality as well—is influenced by the number of tuned circuits—the more the merrier. Tuned circuits cost money, whether they are in the signal-frequency or IF circuits, and this point should be remembered when comparing values.

A receiver that is otherwise suitable should not necessarily be turned down because its loud speaker is faulty or deficient in quality, provided this is taken into account in fixing its price. The attractive possibility of using an external speaker of modern design is thus opened

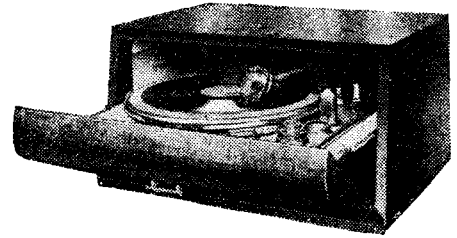

Substitute for a radio-gramophone; a playing desk, in conjunction with an ordinary set is often found to be very satisfactory, and in many respects more convenient.

up, and as a rule it will be found more satisfactory than a built-in instrument, notwithstanding the present vogue. A permanent-magnet model will probably be chosen, while the field winding of the disused speaker can still be used for its original function of smoothing.

Those who are fortunate enough to be able to have actual demonstrations of receivers that appeal to them should be constantly on their guard against being influenced unduly by local conditions. Many a good set has been unjustly condemned after a trial in circumstances where it has no chance of showing its capabilities with regard to range and quality of reproduction, while, on the other side of the picture, those who live in flats or in other (wirelessly speaking) undesirable residences are apt to forget that a set which behaves well when connected to a good aerial in an interference-free locality may seem much less attractive in their own homes. Above all, beware of judging a "high-fidelity" set under conditions of bad interference; the background noises are often appalling.

If extreme range is desired, the demonstration should be arranged for day-time, as the capabilities of a set in that direction can then be more accurately assessed. But range (or sensitivity) is closely linked with selectivity, and where comparative tests between different receivers can be made, a weak station sandwiched between two high-power and relatively near-by transmitters should be chosen as the basis of the test.

Working Instructions

It is sometimes a matter of importance that the instruction book of the receiver chosen should be available, and if there is a circuit diagram so much the better; a knowledge of the internal connections adds enormously to the true value of the set in certain circumstances.

Thanks to a greater baffle area, a radio-gramophone is likely to provide rather better quality than a small table model, but the gramophone enthusiast who is unable to find a "combination" set that suits him may be reminded of the possibilities of using a playing desk with an ordinary receiver.

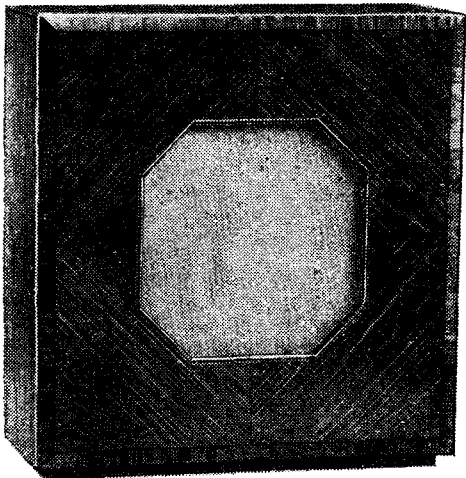

The possibilities of using an external cabinet speaker may sometimes be considered.

The Second-Hand Set

—Circuit and Performance

MANY reasons can be advanced for the purchase of a second-hand receiver. It may be bought because one cannot afford a new one or because it is required as an auxiliary to an existing set for occasional use, and the higher price of one of the latest productions is not considered justifiable—to instance only two cases which are actually very similar. Only these will be considered in this article, and it will be assumed that it has been decided to buy a second-hand set because it is believed that the required performance can be obtained more cheaply than if a new set were acquired. The performance, of course, may not be as good as that of one of the latest designs, but there are many cases where in regard to the basic factors of sensitivity, selectivity and quality it may quite closely approach it. The set will, however, lack many of the refinements which are now an accepted part of modern design—refinements such as AVC, tone-control, noise-suppressor, mains filter, visual tuning indicator, provision for a pick-up or external loud speaker.

Whatever the receiver may be, its performance can be improved, and the poorer results which it gives the greater the possi-

are then likely to bring it close to the standard which has been set up.

When the purchase of a second-hand receiver is contemplated, therefore, the first step is to make a list of the characteristics required. The receiver to buy is then the one which comes nearest

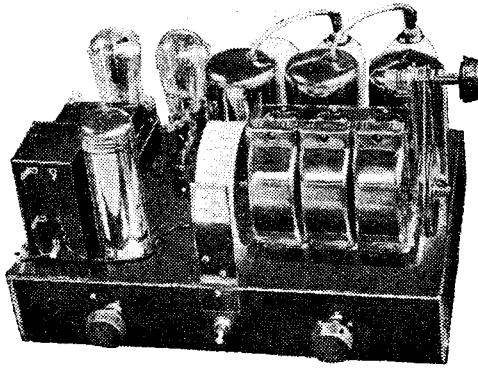

The chassis of the Cossor 533A receiver with two HF stages and three tuned circuits.

to this standard of comparison, provided that its price is satisfactory and it appears likely to function reliably. This question of reliability is quite important, and will be dealt with in future articles. In deciding on the performance the use to which the set is to be put must be carefully considered. A less sensitive and selective set is necessary if local reception is chiefly required than if distant listening is thought to be of great importance. In either case a more sensitive set is necessary if an indoor aerial has to be used than if a good outdoor aerial can be erected, similarly a lower standard of selectivity will suffice if the nearest transmitter is fifty miles away than is needed if it be within one mile. Again, a choice must be made between a mains and a battery operated receiver.

AC, DC or Battery ?

It is impossible to lay down hard-and-fast rules by which the right set may be selected in all circumstances, and each case must be decided on its merits.

In general, a battery receiver should be selected only when mains are not available, for its performance is not likely to be as good as that of the equivalent mains set, and its upkeep will cost more. For an AC supply no difficulty arises and an AC set should invariably be chosen, but for DC mains the question is somewhat more difficult. A universal AC/DC set is an advantage if there is any probability of the supply being changed to AC in the near future, but it is by no means essen-

Notes on the Capabilities of Different Receiver Types

tial, for it is not difficult to modify many DC receivers for universal operation. In selecting a DC set this point should be kept in mind, and it should be remembered that the change-over will usually necessitate a new set of valves. Moreover, as universal valves are fitted with 7-pin bases, and most DC types with 5-pin bases, the valveholders will have to be changed, and the set should be chosen in which the mechanical difficulties involved in the fitment of larger valveholders are not too great.

In the past the three-valve straight set represented one of the most popular types, and it is still very widely used. The usual set has one HF stage, a grid detector with reaction, and a pentode output valve. Sometimes three tuned circuits are included, sometimes only two. A receiver of this type can give very acceptable quality of reproduction, and in most districts it is sensitive and selective enough to enable quite a number of distant stations to be well received when an outdoor aerial is used. The chief fault of the set in the eyes of one accustomed to modern design lies in the selectivity,

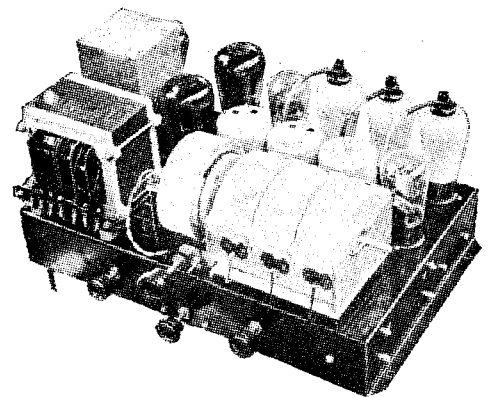

Gambrell-Halford superheterodyne utilising a two-valve frequency-changer and a signal-frequency stage of amplification.

which is low compared with that of a superheterodyne, and which cannot be considered high enough for general distant reception, although it may be so on occasion. There is, moreover, little which can be done to improve the performance

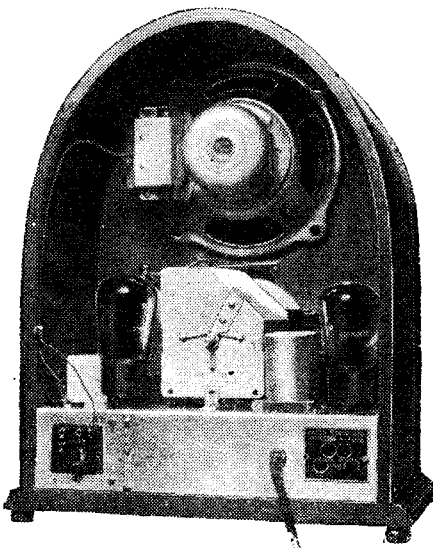

Bush Radio three-valve straight set with screen-grid detector and pentode output valve.

ble improvement. This most decidedly does not mean that it is economical to purchase a set of poor performance, for the alterations necessary would probably cost much more than the price of the set. The aim should rather be to obtain a receiver which, unaltered, gives a performance as close as possible to that desired. Minor improvements costing only a few shillings

The Second-Hand Set—Points for Purchasers— of this type of receiver. Neither the sensitivity nor the selectivity can be improved to any extent, and the only method of alteration which is worth while is to rebuild it completely, using it merely as a basis for a new receiver. In the case of a battery model, however, when the sensitivity and selectivity meet the requirements of the buyer the addition of a QPP or Class "B" output stage is worth considering. Although the initial expense of such an addition is an appreciable item it is likely to be worth while in the long run through the reduction in the current consumed from the HT battery and the greater volume which can be obtained without distortion.

Automatic Volume Control

The two HF straight set, although never very widely adopted, is far more suited to the needs of the distant listener, for it is both more sensitive and more selective while yet lending itself better to improvement. If originally well designed, sets of this type have ample sensitivity for all ordinary purposes, and the selectivity, although lower than that of the superheterodyne, is sufficient to permit most of the musically worth-while Continental stations to be received without any serious degree of interference. There is also more scope for modification in such sets than in the case of smaller ones, and it is usually readily possible to add automatic volume control and so greatly reduce the effects

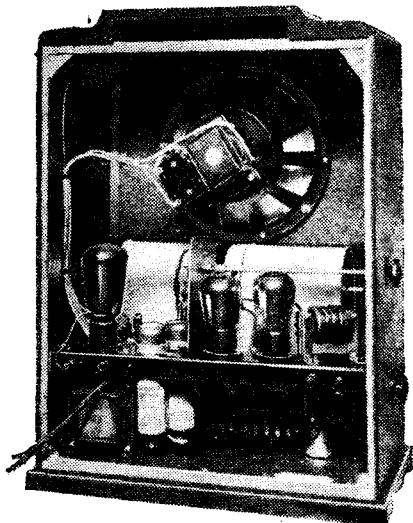

The Amplion Six straight set for AC mains with two HF stages, four tuned circuits, and a push-pull output stage.

of fading in distant reception. The methods which must be adopted to include AVC will naturally vary from set to set; in some cases the addition of a Westector with a number of condensers and resistances will suffice, in others one of the valves must be changed for a duodiode-triode, while in a few cases an additional valve will be necessary.

In spite of the good performance of which the straight set is capable the superheterodyne is likely to be a more popular choice, for most examples are much more selective and the sensitivity of even the

small sets is likely to equal that of quite large straight sets. Moreover, the superheterodyne can be brought up to date much more readily. The ease with which AVC can be added to a typical superheterodyne of a few years ago is demonstrated elsewhere in this issue. The possible changes, in fact, are limited chiefly by the ability of the purchaser to

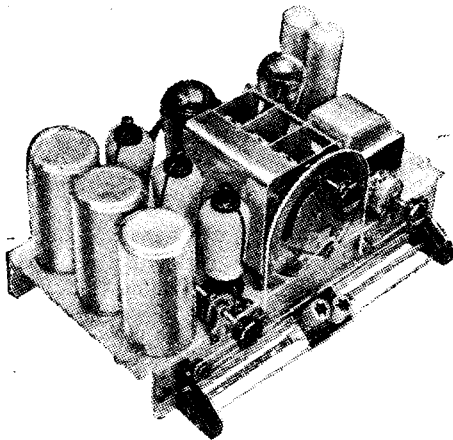

The chassis of the Ultra Panther receiver: a straight set with two HF stages and three tuned circuits.

readjust the set after alteration. The addition of AVC calls for little or nothing in the way of such readjustment; other possible changes, such as the fitting of variable selectivity, may necessitate retrimming throughout.

The Frequency-changer.

Although there is much which can be done to improve the performance of the older superheterodynes, in general the aim should be to purchase one which gives the required results with a minimum of alteration. For general all-round use a set which is hard to beat has a single IF stage, detector and output valve, preceded by a frequency-changer, which, in the older sets, may employ two valves and in the newer only one. In the matter of performance there is very little to choose between the two-valve frequency-changer and the single-valve type embodying one of the special valves, such as the heptode, octode or triode-pentode. A change is not usually worth while unless it is convenient for other reasons. A few years back, however, some sets embodied a frequency-changer using a single screen-grid or HF pentode-type valve as detector-oscillator. While such frequency-changers can function very well indeed they may be rather particular as to the valves used, and it is well to make sure that the valves which the designer intended to be used are still available.

Receivers of this general class can give very acceptable quality of reproduction, and when used with any reasonably efficient outdoor aerial the sensitivity and selectivity are adequate for all but the most exacting. Where a poor aerial must be used, or where the reception of weaker signals is required, a similar type of set but with either two IF stages or one IF stage and one signal-frequency amplifier is indicated.

The seeker after quality only for local reception is unlikely to find any suitable set among the popular types, but the listener who requires a good all-round performance is likely to have no difficulty. The quality enthusiast is likely to be best satisfied by buying a set not for use as it stands but as the backbone of an entirely new receiver.

One last word, do not be deterred from buying a set by the fact that it may contain a large number of valves. The fear of the cost of valve replacement unjustifiably deters many from buying multi-valve sets, but in the writer's experience the annual bill for new valves may actually be less in the case of an eight- or nine-valve set than with one having only four or five valves. The reason lies in the fact that, except in the case of the output valves and HT rectifier, the gradual deterioration of valves affects little more than the sensitivity. The sensitivity of a large set, however, is so much greater than is normally required that quite a large deterioration in the valves is possible before the performance is noticeably affected. Partially worn-out valves may continue to give a good performance in a large set when they would be long overdue for replacement in a smaller one.

The 1936 Monodial AC Super

CONSTRUCTORS of this receiver are reminded that two errors occurred in the drawings accompanying the constructional articles. The first consists of the omission of the condenser C from the circuit diagram on page 75 of *The Wireless World* for July 26th, 1935, and this was corrected at the end of the second constructional article. The second consists of the reversal of the connections to the grid and anode sockets of the ML4 valve holder in the practical wiring diagram on page 100 of the issue for August 2nd, 1935. This error was corrected in *The Wireless World* for August 16th, 1935, and all blueprints now supplied are correct.

The Amateurs' Handbook

A Guide to Amateur Radio, 3rd edition.—92 pp., with 100 diagrams and illustrations. Published by The Incorporated Radio Society of Great Britain, 53, Victoria Street, London, W.1. Price 6d.

THIS edition of the Amateurs' Handbook has been very much enlarged, for not only has all the technical matter been revised and brought up to date, but more space is devoted to construction than in any other previous edition.

The technical matter is presented in a manner easily understood by the beginner yet it is by no means elementary and the experienced short-wave experimenter will find much of value to him. A large amount of valuable data is provided in the form of curves and formulae and there are numerous circuit diagrams, all of which are carefully prepared and very informative.

The handbook covers every aspect of amateur activities on the short- and ultra-short waves, including the procedure to be followed by those having receiving experience and who aspire to the ownership of a fully licensed transmitting station.

H. B. D.

A NEW TUNING INDICATOR

Cathode Ray System from America

By J. H. REYNER, B.Sc., A.M.I.E.E.

THE idea of using a cathode ray device for tuning indicators has been in the minds of designers for some time, for the bright fluorescent glow which can be obtained with modern screen materials is very suitable for giving a clear visual indication.

A PARTICULARLY neat form of indicator has just made its appearance on the American market. The device, which is known as the 6E5 tube, is made in the form of a valve and fits a standard American socket. It provides a circular disc of light on which appears a wedge-shaped shadow which varies in thickness according to the value of the carrier, being broad under normal conditions but narrowing down to a thin line when full carrier voltage is applied.

One of the difficulties with cathode ray equipment is that, if satisfactory brilliance is to be obtained, the control voltage is apt to be more than can conveniently be provided by any existing point in the receiver. This is overcome in the 6E5 tube by including in the device a valve which acts as a DC amplifier and thus delivers a magnified control voltage. In this way full operation is obtained off the normal AVC voltage developed in the set.

The construction of the tube is similar to that of a normal valve, except that the grid and anode only surround the bottom portion of the cathode, which extends through the top mica into the indicator portion proper.

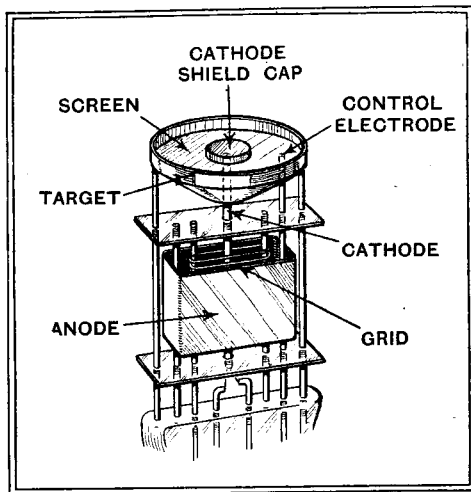

Fig. 1.—General construction of the 6E5 tube.

Immediately over the top of the cathode is a circular fluorescent disc surrounded by a short cylindrical anode. Normally, therefore, the electrons attracted from the cathode by the positive

potential on this auxiliary anode or target would hit the fluorescent screen in their passage, and cause it to glow more or less uniformly. The centre of the fluorescent screen is provided with a small cap which shields off the light from the hot cathode itself.

There is, however, an auxiliary electrode situated between the cathode and the target consisting of a short rod con-

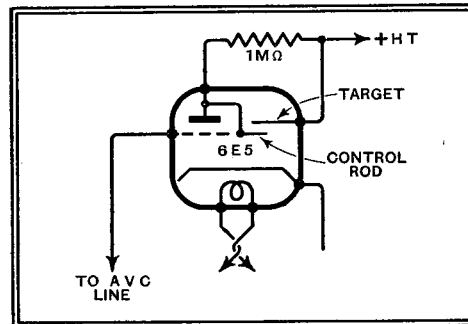

Fig. 2.—How the electrode connections are arranged.

nected to the anode of the triode section. This rod is maintained at a potential a little lower than that of the target itself, and this repels the electrons in the neighbourhood of the rod. Consequently, the electrons are diverted in the region around the control electrode, so that a dark patch or shadow appears at one side.

Variation of Shadow Width

The width of this shadow depends on the voltage on the control electrode. If this voltage is high, so that the electrode is nearly at the same potential as the target or main anode, the diversion of the electrons is small, and the shadow produced is in the form of a thin line. As the voltage on the control electrode becomes more negative relative to the target, an increasing number of electrons is deflected to the opposite side of the tube, giving a gradually broadening shadow. Due to the location of the control electrode, this shadow is wedge-shaped in form, as shown in Fig. 3.

The actual circuit is shown in Fig. 2. It will be seen that the control electrode is connected internally to the anode of the triode section. This obtains its voltage from the full HT (target) potential through

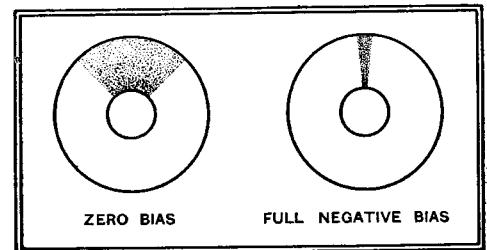

Fig. 3.—The shadow varies in thickness according to the value of the carrier.

a one-megohm resistance. The grid of the triode is connected to the AVC line so that normally the valve is only slightly negatively biased, causing an appreciable anode current flow and a correspondingly large voltage drop on the anode resistance. The control electrode is thus appreciably negative relative to the target, which results in a wide shadow.

As the AVC voltage increases, the grid of the valve runs negative, the anode current decreases, and the anode and control voltages rise rapidly, causing the shadow on the screen to become progressively narrower until it reaches the limiting position when the control electrode is practically at target potential.

Characteristic Curve

Fig. 3 illustrates the type of indication obtained while the characteristics of the tube are shown in Fig. 4. The target current is practically constant at about $4\frac{1}{2}$ milliamps, being slightly less when the shadow is large, as one would expect. The anode current of the triode section is very small, in view of the high resistance through which the tube operates, and it is, of course, controlled by the grid bias in the normal way. The shadow angle varies between approximately 90 degrees and zero under normal conditions.

The scheme is an ingenious one, and the use of cathode ray streams for devices of this character may well play an increasing part in the technique of future radio receivers. It is possible, for example, to imagine relays constructed on this principle, and it may be that the 6E5 tube is the forerunner of a new class of thermionic device.

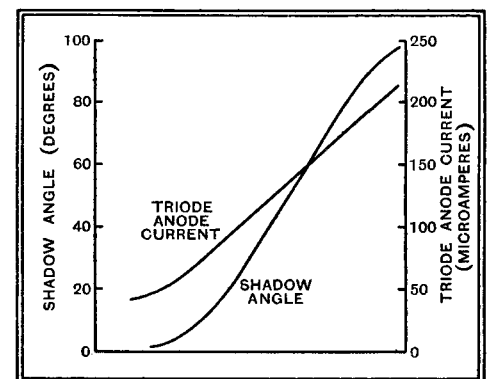

Fig. 4.—Characteristics of the tube.

Current Topics

Events of the Week in Brief Review

League Tells the World

THE Italo-Abyssinian war is reflected in the increased activity of the League of Nations' transmitters at Prangins, Geneva. Two transmitters are in constant use: HBL on 32.10 metres and HBP on 38.47 metres. Many of the broadcasts are intended for world consumption.

Radio Festival in Brussels

AN international radio and cinema festival is being held this month in the Palace of Science at the Brussels Exhibition. One of the lecturers is M. Raymond Brailard, President of the Technical Commission of the International Broadcasting Union, who is dealing with "The International Organisation of Broadcasting." M. C. Florisson is lecturing on marine sounding devices.

Palestine Calling

DURING intervals in the North Regional transmissions listeners may soon obtain "freak" reception from the new broadcasting station in Palestine, which, in accordance with the Lucerne Plan, will work on the 449.1-metre wavelength with a power of 20 kilowatts. Programmes will be in English, Hebrew, and Arabic. The director of programmes will be an Englishwoman, Miss Clarissa Graves.

Anti-static Campaign

THE sources of electrical interference in France are being dammed in such large numbers that one is prompted to ask whether a similar amount of interference would be revealed in this country if such a campaign were launched by the Post Office.

During September the "anti-parasite" engineers of the French Post Office carried out 3,345 investigations which resulted in the tracing of 13,517 electric generators of disturbance whose owners were immediately ordered to fit suppression devices.

Transmitting from the Stratosphere

ULTRA-SHORT-WAVE transmitters attached to small balloons are now used by the U.S. National Bureau of Standards in instruments described as radio meteorographs. The radio transmitters, adjusted to emit several short contacts a minute, radiate signals that can be heard fourteen miles up in the stratosphere.

Russian Radio Award

THE memory of Alexander Popoff, father of Russian wireless, is perpetuated in a new award, the "Alexander S. Popoff Prize," to be presented each year by the Soviet radio authorities for the best scientific work in the domain of radio.

Talking Book

A "TALKING BOOK" is referred to in the Twentieth Annual Report of St. Dunstan's. This instrument is a gramophone in which the records revolve at a much slower speed than the normal, thus enabling twenty-five minutes of reading

"Suppression Devices"

A LECTURE on "Suppression Devices" will be given under the auspices of the National Radio Engineers' Association, Ltd., at the Bush Hotel, Shepherd's Bush, at 8.15 on Tuesday next, October 22nd.

Truth About Taxi Radio

TAXI radio has not caused more accidents in Paris, according to information vouchsafed by M. Langeron, Prefect

broadcast the principal lectures at the Sorbonne and the College of France.

A Radio Roosevelt

MR. ELLIOT ROOSEVELT, the 27-year-old son of the American President, has chosen radio as a career, having joined the Southwest Broadcasting System, operating a chain of stations in Texas and Oklahoma. Strangely enough, Herbert Hoover, Junior, son of the late President, graduated from the ranks of radio amateurs to take charge of radio communications on the Transcontinental and Western Air Lines.

Why Tokio Talks Most

STOCKHOLM is the most "religious" of all broadcasting stations, according to an interesting analysis recently issued by the International Broadcasting Union. Budapest devotes more time than any other station to "serious" music, 36.3 per cent. of its programmes being of this type. Madrid, where light music reigns, is at the other pole. Tokio talks more than any other transmitter, and Algiers is the most taciturn, only 2.1 per cent. of its transmissions consisting of talks.

Rome devotes most time to opera, Huizen the least. Radio-Paris is the most "studious" and Copenhagen, with its gymnastic sessions, "the most sporting." Tokio, with its flood of talk, is, as might be expected, the "most feminine."

The R.S.G.B. Guide

THE "Guide to Amateur Radio," published by the Incorporated Radio Society of Great Britain, is already firmly established as a compendium of up-to-date information on short-wave amateur radio. The third edition, just issued, includes constructional articles dealing with a five-metre transmitter and receiver, as well as a simple short-wave receiver designed for use in conjunction with a modern 10- to 25-watt crystal control transmitter.

One of the most interesting sections to the comparative tyro is the chapter entitled "From B.R.S. to Fully Licensed."

The Guide may be obtained for 8d., post free, from the Radio Society of Great Britain, 53, Victoria Street, S.W.1.



GERMAN AMATEURS are growing in number as a result of official encouragement and the raising of licence restrictions. Above are a typical short-wave station and its owner's QSL card. All-metal construction is favoured.

aloud to be contained on one side of a record. St. Dunstan's is establishing a central library of recorded books: classics, travel, biography, novels, etc. The whole of an average book can be included on from ten to twelve double-sided records. Special postage rates are allowed for the records, and authors and publishers are giving free copyright.

This is only one example of the manifold activities of St. Dunstan's in its work on behalf of war-blinded soldiers.

of Police. Moreover, it would appear that Parisians, having grown accustomed to the novelty, no longer rush for cars marked "T.S.F."

France's Radio University

FRENCH listeners can now obtain by radio all the instruction necessary to pass matriculation as a result of a new series of transmissions introduced at the instigation of M. Mandel, the Postmaster-General. As from November 1st Radio-Paris and the PTT stations will

Aerodyne "Aeromagic"

WHATEVER may have been the conjectures of the technical experts when this set was first introduced at the Radio Exhibition, there was general agreement that any device which resulted in a really practical realisation of the idea of remote control was certain to have a large following. Hitherto schemes for controlling the set from an armchair have fallen through either because of backlash in the mechanical controls employed or because the devices used for stopping the tuning controls at predetermined positions were not readily adaptable to changes in the wavelengths of stations.

FEATURES.—Type.—Table model superhet for AC mains with automatic tuning and remote control. **Circuit.**—Octode frequency-changer—var.-mu pentode IF amplifier—double-diode detector—pentode output valve. Automatic tuning valves—pentode IF monitoring stage—triode relay valve. **Controls.**—(On set) (1) Tuning. (2) Tone. (3) Waverange. (On remote-control unit) (1) Volume and on-off switch. (2) Starting button. (3) Reversing switch. **Price.**—23 guineas. **Makers.**—Aerodyne Radio Ltd.

the set through a 10-way cable. It incorporates a press button for starting the small electric motor which drives the tuning condenser in the set, a reversing switch for retraversing the tuning scale and a combined master switch and volume control. There is also a meter-type instrument, calibrated in stations and wavelengths, which follows the setting of the main tuning scale and enables the

at work. After allowing the usual time for the valves to warm up the starting button is depressed and the scale pointer searches the waveband while the loud speaker is muted. The only sound during this phase is a faint whirring from the electric motor and gearing in the set itself. Eventually the pointer stops with a click and the station at which it has stopped breaks in at the volume which has been previously

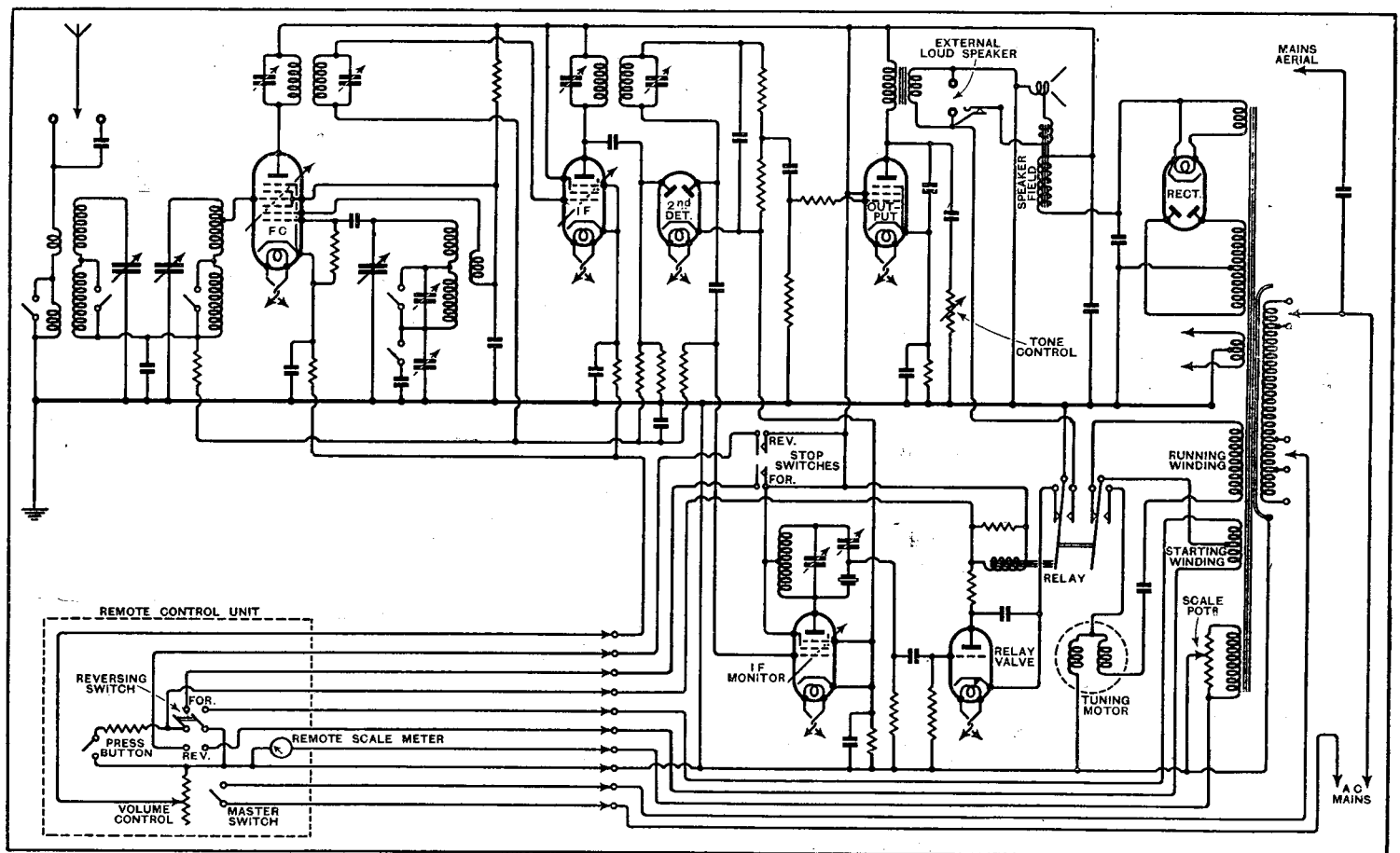

Complete circuit diagram. The four-valve superheterodyne circuit is supplemented by a quartz crystal and two additional stages for automatic tuning.

The Aerodyne scheme circumvents both these difficulties; the remote control is electrical and not mechanical, and the station carrier wave itself is made to stop the tuning control when the set is exactly in tune with the station. Thus, if a slight change were made in the official wavelength of a station the "Aeromagic" set would find the new setting automatically and tune in the station precisely and without any trace of sideband distortion.

The remote control unit is connected to

user to identify the station to which the set has tuned itself.

The waverange switch is on the set itself. It could have been incorporated in the remote control, but the makers rightly considered that the additional cost was not justified, as usually this switch is used only two or three times during the course of an evening.

Apart from the obvious utility of the system in everyday listening there is an undeniable fascination in watching the set

determined by the setting of the control. There is no time delay, as the station was already accurately tuned before the loud speaker was switched on.

The volume control operates on the frequency changer and IF valves, and it can be so adjusted that the automatic tuning device stops only on those stations which are of programme value. This feature is also useful for cutting down background noise during periods when atmospheric conditions are prevalent, as a strong atmospheric as

Technical Details of The Self-Tuning and Remote-Control Devices

well as an authentic carrier wave is sufficient to trip the relay.

Any scepticism as to whether the station is, in fact, accurately tuned-in when the pointer stops is at once removed when the hand control of tuning on the set itself is operated and the station tuned in by ear. It will be found that the manual and automatic tuning positions do not differ by more than the thickness of the hair line on the pointer. Another check was obtained by reversing the motor and pressing the starting knob again immediately after a station had been tuned in, when it was found that if the pointer moved at all it was again only by about the thickness of the hair line.

Setting the Tuning Indicator

There is one point in connection with the remote tuning scale which must be watched. As this is virtually a voltmeter and derives its deflecting current from a potentiometer across a winding on the mains transformer the scale reading will depend to some extent upon the mains voltage. For this reason the makers have provided an intermediate tapping in the mains voltage adjustment so that the primary voltage can be adjusted in small steps to bring the remote scale into exact agreement with that on the set itself. In the set tested, incidentally, the range of the volume control was rather crowded



The thirty-yard connecting cable makes it possible to control the receiver from a position convenient to the user.

towards one end, but we understand that this matter, which is only a question of adjusting resistance values, is receiving attention.

The method by which the receiver is tuned exactly to the mid-point on any station is both ingenious and sound. A monitoring IF amplifier is fed with a part of the main IF output, and in its anode circuit is a quartz crystal having a resonance frequency exactly in the middle of the IF band-pass range. A bridge-type

circuit is used to balance out the capacity of the crystal, and the output from the anode circuit of the monitoring valve is passed to the grid of a triode relay valve. As the tuning scale slowly approaches the setting of a station the beat frequency gradually approaches that of the quartz crystal. It does, in fact, pass one of the humps of the IF response curve, and unless the loud speaker were short-circuited quite strong signals would be heard before the crystal resonance frequency was reached. The sharpness of tuning of this circuit, however, ensures that the relay will not be released until the exact centre IF resonance curve is reached. When this occurs a pulse of short duration reaches the grid of the relay valve and reduces the anode current, so that the mechanical relay in its anode circuit operates and so stops the motor and opens the loud speaker circuit.

In developing the set it was found at first that the duration of the pulse was too short to work the relay even when the speed of operation of this component was of the order of only a few milli-seconds. Accordingly, the relay valve was given a time constant by connecting a suitable condenser and leak in its grid circuit. Contacts on the relay are arranged so that any change in the conditions in the relay valve will not cause the contacts to close again until the control button is pressed.

The motor which drives the spindle of the tuning condenser is of the self-starting induction type and is of Aerodyne design and manufacture. It is fitted with the usual running and starting windings on the stator and has a laminated rotor

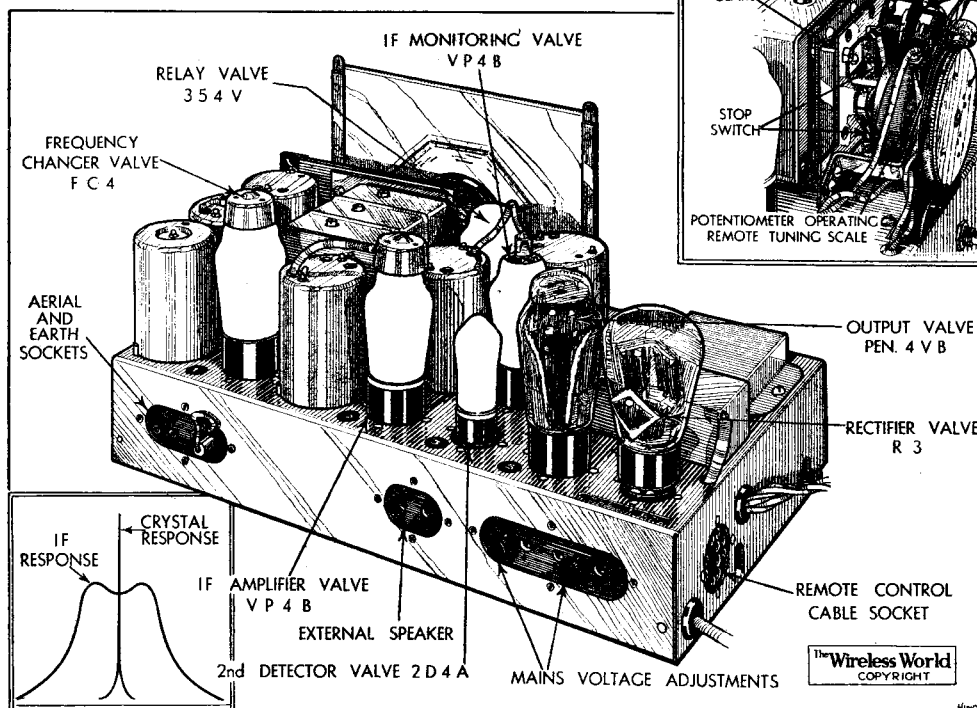

General view of chassis and details of the driving mechanism for remote tuning control. The lower inset shows diagrammatically the crystal response in relation to the IF band-pass curve.

Aerodyne "Aeromag" —

with heavy copper eddy current rings. The voltage for the starting windings is obtained from a separate centre-tapped winding on the mains transformer which gives the necessary phase reversal to determine the direction of the starting impulse. To prevent the motor from over-running the limits of the tuning scale, switches are fitted at both ends which are operated by a peg on the condenser spindle.

The spindle is driven through a train of gears with a high reduction ratio, and to ensure against over-running after the impulse from the crystal has been received the motor, which necessarily has a high momentum, is declutched by withdrawing the driving pinion, much after the same principle as that employed in a car starter. The rotor is held out of centre by a light flat spring, and when the current is switched on the field of the stator pulls the rotor into line and so meshes the pinion with the main train of gears. Although the principle is straightforward, a good deal of time and research has gone to perfecting the detail of the mechanism and to ensure that it will be reliable and foolproof.

Receiver Performance

The set itself is a good, straightforward four-valve superheterodyne. Iron-cored coils are used in the medium-wave section of the input band-pass filter which is followed by an octode frequency-changer and a variable- μ pentode IF amplifier. The detector is a double-diode which provides AVC in addition to signal rectification. Incidentally, the circuit is so arranged that the IF monitoring valve provides some extension of the range of AVC. Resistance coupling is used between the detector and the pentode output valve. There is no LF volume control and the HF volume control at the remote-control panel consists of a variable resistance which is part of the bias resistances of the frequency changer and IF valves. The output from the pentode is shunted by the usual variable resistance and condenser tone control and the secondary of the output transformer is provided with sockets for the connection of an external loud speaker. These are so arranged that the external loud speaker, the internal loud speaker, or both, may be put into operation.

The range of the set is such that after dark the automatic tuning device will be stopping at every other degree on the tuning scale unless the volume control is turned down, and the selectivity is sufficient to give clear reception outside one channel on either side of the Brookmans Park transmitters when using the set in Central London. The long-wave selectivity is also excellent and the Deutschlandsender can be easily separated from Droitwich and Radio-Paris if the tone control is turned down slightly from the position of maximum brilliance. In actual fact the automatic tuning device will stop on the

Deutschlandsender when both the adjacent stations are working—an unusually severe test.

The balance of tone is good and the set excels in the reproduction of individual instruments of the orchestra. The high-note response is unusually good for a set of this type, and hand clapping, which is a good test of transient response, is very natural.

The success of a set of this type is largely dependent upon the reliability of the mechanical devices incorporated, but judging from the quality of workmanship throughout no fears need be entertained on this score.

NEWS FROM THE CLUBS**Healthy Signs**

IF early signs can be relied upon the coming club season should be one of the most successful in the annals of amateur radio. In all parts of the British Isles wireless clubs (not forgetting the television societies) are already holding weekly meetings with attendances which show that there was never a time when interest in the scientific side of wireless was more pronounced.

New Philco Sets

At last week's meeting of Slade Radio (Birmingham) Mr. Willis, a member, demonstrated the latest Philco receivers, the first being a seven-valve all-wave superhet., the second a four-valve universal receiver, and the last a new battery set, only just released. The club meets

LOTUS MODEL 333**A New Midget Universal Set**

ALTHOUGH the dimensions of this receiver are only 10in. \times 8 $\frac{1}{2}$ in. \times 7in. the circuit specification includes a barretter voltage regulating lamp and an indirectly heated rectifier valve. Pentode valves are used throughout in the straight three-valve circuits, and tuned-grid coupling is used between the HF and detector stages and resistance coupling between the detector and output valve. Single-control ganged tuning is employed and the illuminated dial is calibrated in wavelengths. The set includes an energised moving-coil loud speaker and the price is £4 17s. 6d.

the last meeting Mr. G. Roberts demonstrated the new Murphy receiver incorporating automatic tuning and silent AVC. Enquiries respecting membership will be welcomed by the Hon. Secretary, Mr. A. Buckley, 52, Vicarage Avenue, Gildersome, Leeds.

Home-Made Bass

On Tuesday next, October 22nd, the Croydon Radio Society will hold a "Gramophone Pick-up Night" at the headquarters, St. Peter's Hall, Ledbury Road, South Croydon.

A novelty in lectures was given by the President, Mr. H. R. Rivers-Moore, at a recent meeting, when he demonstrated how the amateur musician could use broadcasting and gramophone reproduction to improve his own playing. Mr. Rivers-Moore, using his double bass to accompany music on his gramophone amplifier, showed how the playing of one's own instrument could be learnt in a very pleasant way. He also showed that the performance of an old loud speaker could be very considerably improved by the addition of home-made bass. Hon. Secretary: Mr. E. L. Cumbers, 14, Campden Road, South Croydon.

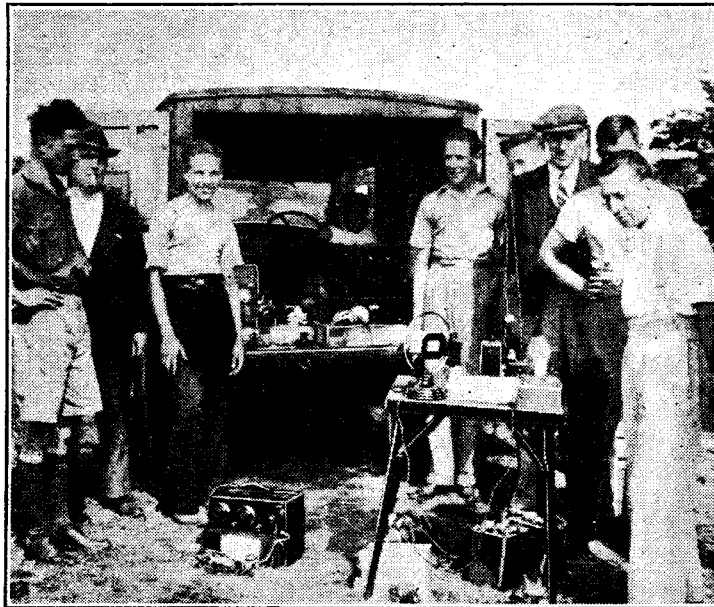

AN ECHO OF SUMMER. Members of the Kentish Town Radio Society photographed during a recent 5-metre field day.

weekly at the Shakespeare and Dickens Rooms, Edmund Street. Hon. Secretary: Mr. C. Game, 40, West Drive, Heathfield Park, Handsworth, Birmingham.

Dancing to America

Members of the Anglo-American Radio and Television Society recently danced in Uxbridge to American bands picked up from W2XAF, Schenectady. The American station was co-operating by special arrangement. In the near future members will be enabled to dance to the music of Rio de Janeiro, Havana and Chicago. Hon. Secretary: Mr. Leslie W. Orton, "Kings-thorpe," Willowbank, Uxbridge.

All-the-Week Television

The Yorkshire Television Association's club-room at the Queen's Picture House, Meadow Road, Leeds, is available for the use of members each evening throughout the week. At

A Radio Auction

An auction and mart of radio components is to be held by the Bradford Experimental Radio Society on Wednesday next, October 23rd. An interesting programme has been prepared for the coming session and will include visits to Moorside Edge and to the G.P.O. telephones department. Hon. Secretary: Mr. E. P. Burgess, 23, Baslow Grove, Heaton, Bradford.

For Manchester Enthusiasts

All radio enthusiasts are welcomed at the meetings of the Manchester Chapter of the International Short-Wave Club which meets on the first and third Tuesday of each month at 8 p.m. at the British Legion Offices, Long Street, Middleton. Hon. Secretary: Mr. R. Lawton, 10, Dalton Avenue, Thatch Leach Lane, Whitefield.

BROADCAST

By Our Special Correspondent

BREVITIES

Broadcast the Royal Christening

ROYAL weddings and royal obsequies have been broadcast, but up till now we have never listened to a royal christening.

A relay of the christening of the new Prince would be keenly listened to by millions of listeners all over the Empire. Is it too much to hope that this important event can be put on the ether?

In Wildest Warwickshire

ONE need not go to the Wild West for the wild life of the backwoods. The B.B.C. education officers come up against primitive existence in the heart of England. The other day one of their number called upon a school in Warwickshire—a two-roomed building with only one approach road, two teachers, thirty-nine children, all of whom were inter-related, and a broadcast receiver.

"World History, Please..."

The B.B.C. man advised the principal to take a few instead of all the broadcast lessons. To his surprise he was met by a demand from the children for "plenty of world history." The explanation was that the children thought that the nearest town was the only place of any importance on the globe, and that "plenty of world history" would give them all the gossip from the nearby metropolis.

Can Radio Preserve School Discipline?

Among the interesting discoveries of the education officers is that no B.B.C. talker, however powerful his microphone personality, can command discipline in a schoolroom when the teacher is absent. It is hoped, though, that television may change this state of affairs, because the majority of pupils will forget that the face they see in the receiver cannot see them.

"Ticked Off" by Television

The time may come when the education profession may be concentrated at Broadcasting House, leaving, perhaps, one travelling teacher to tour each county, just to make sure that the little ones are sitting quietly before the television receivers.

The technique of preserving discipline by television will, of course, have to be studied. Such shots in the dark as: "Don't stand on that desk," or, "Take your fingers out of the ink, Johnny," will have to be used with moderation.

Why Not?

FROM Addis Ababa I hear that American radio reporters are already to be seen in the environs of the city. They carry sandwich boards bearing the words: "Radio reporter! Do not shoot!"

Considering some commentaries that I have heard it would be as well if such notices were carried by radio reporters everywhere.

NEW INSTRUMENT FOR BROADCASTING. Stanelli and his Stanelli-phone, a combination of piano and xylophone, which he will play, with Sydney Jerome, in a forthcoming gala programme.



A Football Problem

ALTHOUGH the B.B.C. is very happy over having arranged with the Football Association to broadcast a commentary on the Cup Final, there is, of course, the proverbial fly in the ointment.

The match is timed for two o'clock, and the B.B.C. is wondering whether to accede to the requests of some of the League clubs for permission to relay the commentary to spectators assembled on their grounds prior to the local matches.

Exceptions

It is usual to preface these broadcasts with a warning that the commentary is copyright by the B.B.C., but while the Corporation would not object to rediffusion in the case of the Cup Final, various other interests have to be consulted.

The only occasion on which the copyright ban has been waived has been in connection with the Armistice Day service from the Cenotaph and the Royal Wedding of last November.

Television from Wembley?

If the B.B.C. does waive its copyright in connection with the Cup Final in the case of League club football grounds it can hardly withhold the same concession from shops and other public places.

However, there are six months in which to decide. Perhaps by March next we may be demanding a television relay from Wembley.

"Ultra Shorts" from Broadcasting House

Talking of television reminds me that some interesting 7.75-metre transmissions are being exchanged between the roof of Broadcasting House and the Marconi-E.M.I. engineers at Hayes and Alexandra Palace.

The ordinary programmes are being used for the tests, which are intended for the trying out of new receiver designs.

This is yet another reminder that the official television transmissions beginning in March next are intended for public consumption. Receivers must be available in good time.

Armistice Day

LORD JELICOE will, as usual, make a broadcast appeal for the Poppy Day Fund on November 10th. The Armistice Day broadcast will follow tradition, the Cenotaph service being relayed, and also one hour

of the Service of Remembrance at the Albert Hall in the evening.

The theme of peace having her victories no less renowned than war will be the motif of an evening broadcast setting forth the heroism of members of the Scott Expedition to the Antarctic.

A Minute Minimum

WHEN does a break in transmission become an interruption worthy of an official apology?

One evening last week it seemed to me that the London Regional programme was punctuated between 10 and 11 o'clock by intermittent contacts at the transmitting end. (I have since discovered flaws in my aerial.) On putting the question to the engineers at Broadcasting House I was asked how long each break lasted. When I said, quite truthfully, "From fifteen to twenty-five seconds," the official retort was that an interruption must be of a minute's duration for an apology to be necessary.

Biggest World Broadcast

THIRTY-ONE countries, I now learn, are to take part in the International Broadcasting Union's World Broadcast on Sunday, October 27th.

The focal point of the record "hook-up" will be Berlin, where technical control will be in the hands of the Reichs-Rundfunk-Gesellschaft.

Visitors from Czechoslovakia

THE Orchestra of the Czech Philharmonic Society, one of the largest in Central Europe, is shortly paying a visit to this country and will be heard by listeners on November 24th from a studio in Broadcasting House, and on November 25th from the Queen's Hall.

The conductor, Vaclav Talich, who joined the Society in 1918, is regarded as the most prominent musical director in his country to-day. A graduate from the Berlin Philharmonic Orchestra, Talich has conducted a large number of concerts on the Continent, in London, Glasgow and elsewhere. Under Talich's experienced and energetic leadership the Orchestra has reached a very high standard; it is particularly famous for the excellence of its strings.

Hungarian Rhapsody

BUDAPEST has invited Eric Maschwitz to stay in the City for a fortnight as the guest of the Municipality.

Revalving

Replacing Valves in Out-of-date Sets

VALVES are generally understood to be among the "consumable" parts of a radio set. But, unless one strikes a bad patch, they are consumed very slowly. There are numerous receivers still working with the original valves, even although they have celebrated many happy returns of the day on which they emerged from the factory; so that the receiver itself may easily have become obsolete before the valves are worn out.

The great majority of sets that have endured several seasons, however, would be the better for renewal of one or more valves. One difficulty is that, unlike petrol in a tank or a month's salary, the valve often shows no very definite signs as to when it is finished. The only entirely satisfactory way of deciding is to test each valve separately as a valve. Otherwise, even such a vital matter as an apparently burnt-out filament or heater may be nothing more than a bad socket contact, and it would be annoying to buy a new valve for that. Unfortunately, complete valve-testing equipment is imperfectly distributed among the listening population, and a dealer or agent who possesses the apparatus and who is also commercially unbiased may be hard to find in the district.

A Gradual Decline

However, if any one valve becomes inoperative, and it has been checked that the power is reaching it, there is a good *prima facie* case for supposing it to have come to the end of its life. More commonly, though, its passing is not sudden, but consists of a slow decline. The symptoms are: less undistorted volume (in the case of the output valve, which is most likely to fail first), reduced sensitivity, or increased background noise. The last of these is particularly difficult to trace, for there are so many possible causes other than valve complaint. Some clue can generally be obtained by knocking each valve in turn when the receiver is working. The noisy valve may respond in some way, such as by a temporary increase or decrease of the particular noise concerned.

Regarding the reduction in performance, obviously one must make quite sure that batteries or power unit, and all connections, including sockets, are in order. A valve used for providing reaction gives a convenient measure of its condition by the setting of the reaction control necessary to provoke oscillation. And a superhet. oscillator that is losing condition will probably cease oscillation over

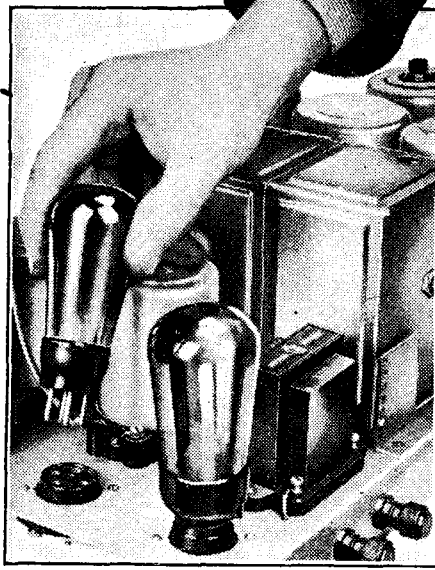

parts of the wavebands. As regards the power rectifier, it is not uncommon for one-half to go out of business, leaving the set to carry on at a reduced rate; this state of the valve is usually visible on inspection—one heater glows where two glowed before.

The decision to scrap a valve having been reached, what remains may merely be a matter of going into the shop and buying another. On the other hand, it may not be. Valve manufacturers continue, at considerable personal inconvenience, to make scores of types of valves that are no longer in the current catalogue. But they must draw the line somewhere. And dealers are not likely to stock hundreds of different obsolete valves in the hope that some day they may be sold.

The makers will actually go to a great deal of trouble to advise one as to the best substitute when an old sort is "out of print." It is at this point that two

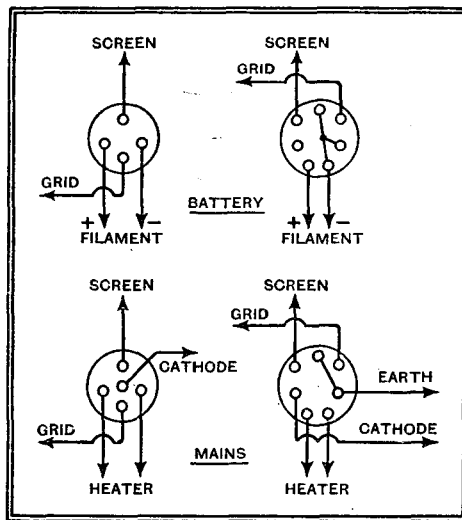

Fig. 1.—Socket connections to be changed when pentodes with early 4- or 5-pin bases are unobtainable.

THE question of valve replacements is not always a simple one, especially if the types originally used in the receiver are no longer obtainable. There is, however, a bright side to the picture, as the substitution of modern valves will often actually improve performance. This article deals mainly with precautions to be taken when making a change.

By M. G. SCROGGIE, B.Sc.,
A.M.I.E.E.

opposite temperaments show themselves. Some folk, of cautious nature, insist on getting just what they had before, and are suspicious of any attempt to provide them with "something better." Those of more adventurous spirit, on the contrary, are quite ready even to scrap a valve that is still working, in the hope of taking advantage of modern improvements. Whether driven by force of circumstances, or whether in a spirit of gay adventure, set owners who are revalving with more modern types must be prepared for the possibility of actually inferior results, and at least minor alterations. It is another example of new and ebullient wine in old and brittle wineskins.

The New Valve Bases

Assuming, first, that one sticks to the same general type of valve—output triode, screen-grid valve, or whatever it may be—the two most likely differences between new and old are a change of base and an increase in "slope," alias mutual conductance. Battery pentodes used to be fitted with four pins and a side terminal, which have given place to the standard 5-pin base. The necessary change of holder, connecting the flying lead to the centre socket, should present no serious difficulty. The earlier mains-driven pentodes (HF and LF) were fitted with 5-pin bases, and have graduated to 7 pins. The change, viewed from below the valve, is shown in Fig. 1. By the way, when renewing power rectifiers, make quite certain that the replacement is correctly half- or full-wave, as the case may be; and that a standard 4-volt rectifier valve is not plugged into a holder fed with the old $7\frac{1}{2}$ volts. Without a major alteration to the power unit, an old type of valve *must* be found for the latter.

Coming now to modernised characteristics; there should be no difficulty in getting an output valve—triode or pentode—having approximately the same, or not more than about 35 per cent. lower, impedance. In such a case the amplification factor is likely to be rather greater than before. The net result is slightly better performance all round, assuming that care has been taken to adjust the grid bias to be correct, and that there was

Revalving—

originally no tendency to instability, which would be increased by the better valve.

The grid bias matter is important. Simply plugging a new valve in would be more likely than not to result in wrong conditions of operation, and perhaps even jeopardy to the valve or power supply through excessive current. There is no control of grid bias in a detector of the very popular leaky-grid type. Therefore it is important to make a wise choice of valve, more especially if a directly-fed intervalve transformer is used. A considerable increase of current through it, besides being uneconomical, would cause bad results by saturation of the iron core. The valve impedance, then, should not be materially lowered. Resistance-coupled or parallel-fed-transformer-coupled detector stages allow much more latitude; almost any valve will work quite tolerably.

Cowardly—but Easy

The most probable result of substituting a more efficient valve in an HF stage is a tendency to instability—uncontrollable oscillation. This tendency may be offset by reduced inter-electrode capacity within

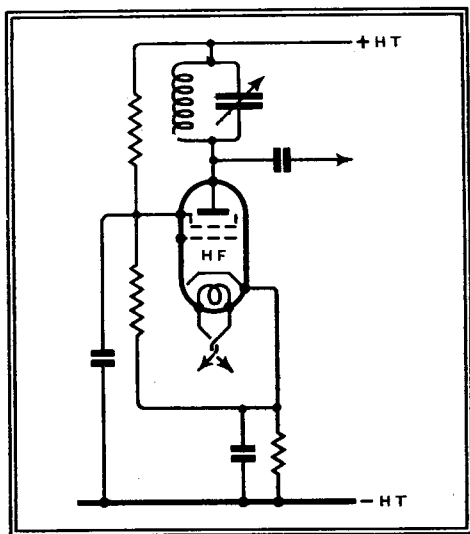

Fig. 2.—A common example of a feed system to a screen grid or pentode valve in which adjustment of screen voltage would influence grid bias also.

the new valve, but if (as is more likely) the trouble is due to imperfect screening without, the proper thing to do is to improve the screening. This is too extensive a subject to deal with here, and it is difficult to give general advice, so one may have to resort to the more cowardly expedient of reducing the surplus efficiency of the valve. The simplest way of doing this is to reduce the screen voltage, either by the direct battery tapping, if provided, or by substituting a voltage-dropping resistor of higher resistance. In any case, when renewing a screen-grid valve or HF pentode it is a good thing to experiment a bit with the screen voltage. But when doing so in a circuit in which both screen voltage and grid bias voltage are supplied through a network of resistors it is neces-

sary to beware of the effects of such experiments being obscured by consequential changes in grid bias. Fig. 2 shows the type of circuit referred to.

While reduction in screen voltage causes loss of amplification a brighter side to the matter—particularly where an oldish receiver is concerned—is that selectivity is improved. The improvement is not marked unless a reasonably efficient tuned circuit forms the coupling; a word to the wise, perhaps.

It may be asked whether it is a good idea to replace the almost obsolete SG tetrode type of valve with a modern HF pentode. Within certain limitations the two types are interchangeable. The increased amplification of the modern valve is realisable only if the tuned circuit is highly efficient. Some of the old sets were exemplary in this respect. Others were not! Another point to watch is the matter of variable- μ . The grid base (number of negative grid volts required to extinguish the anode current) differs considerably, even among those labelled variable- μ . It is usually possible to find a pentode equivalent to the tetrode in this respect; failure to do so is likely to cause the volume control characteristics to be altered. In most cases there is no objection to substituting a variable- μ valve where an ordinary sort was used, even if advantage is not taken of it; and it may be quite an idea to modify the receiver to provide variable- μ volume control if this was lacking.

Ganged tuning is no longer so modern as to be outside the scope of this article; care must be taken when replacing valves in the HF stages that the inter-electrode capacities of the valves are similar, or else that the trimmers are readjusted carefully (near minimum wavelength) to compensate for differences, otherwise appreciable mistuning may result.

Reward of Greediness

It is particularly undesirable to replace a triode detector of moderate amplification factor by one of very high amplification in an attempt to liven up the performance. The likelihood is that the grid will throw heavy damping and mistuning on the preceding tuned circuit.

Another form of "hotting up" that is to be avoided is the substitution of an output pentode for a triode. The chances are heavily in favour of shrill, poor quality, and possibly howling, unless considerable alterations are made. It is possible to convert to Class "B" or QPP to secure greater output or economy in a battery receiver, but not by any simple plugging in.

While the substitution of a single valve of higher slope, in any stage, is unlikely to introduce serious instability—unless the receiver was in a very precarious condition before—the cumulative effect of a general revalving is quite likely to provoke trouble. Howling or motor boating may be quelled by connecting condensers of several microfarads across the HT battery, or introducing or adding to exist-

ing decoupling (Fig. 3). Increasing the resistance R may upset the working conditions, but an increase in the capacity C should be highly beneficial.

Finally, whenever departing from exactly the original types of valves, be on the look out for unusual features in the

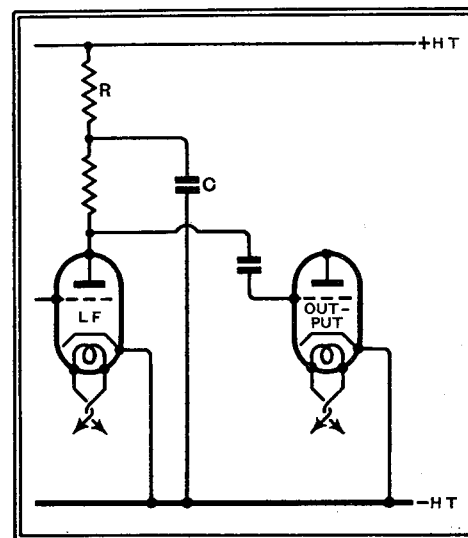

Fig. 3.—R and C are the decoupling components in a typical stage. The most practicable way of increasing its effectiveness is to add to the capacity of C.

receiver, especially if it is well stricken in years. If it is one's own set there is little need for this advice, but readers of *The Wireless World* are, of course, often called upon to salvage the wrecks optimistically alluded to by friends as their wireless. Certain receivers, for example, had all the valve filaments connected in series and fed by rectified current; they would present a nasty problem in valve replacement. Then more than one valve may be fed through a common voltage dropper, and removing or replacing one of them by a slightly different type sends the operating conditions off the map. In such second-party cases it is as well to be armed with recommendations regarding current models!

THE RADIO INDUSTRY

A 24 pp. book entitled "A Camera Commentary on Radio in the Home" has just been issued by the Gramophone Company. It includes a number of attractive photographs showing H.M.V. instruments in home surroundings, and for the first time reveals the interesting story of the famous H.M.V. Trade Mark—the picture of a dog listening to an old-fashioned gramophone.

We have received a leaflet giving details of the service activities of Holiday and Hemminger, of Holmer Works, Dolefield, Bridge Street, Manchester, 3. The firm specialises in repair work, and, with the object of giving prompt and cheap service, has installed special equipment; free collection and delivery is undertaken within five miles of the centre of Manchester.

The many readers who, to judge by our correspondence columns, are still interested in crystal receivers will find it useful to know that crystals are sold by A. Hinderlich, 2, Bridge Road, London, N.W.10. A complete detector with a sensitive zincite-tellurium combination costs 2s. 6d.



JACK PAYNE'S RADIO PARTY is the highlight in the National programme to-morrow (Saturday) at 8.30. Here he is with his boys in a scene from his new film, "Sunshine Ahead."

Listeners' Outstanding Broadcasts

The cast for next week's show includes Scott and Whaley, Ike Hatch, Percy Parsons, C. Denier Warren, Harry Pepper and Doris Arnold, the Kentucky Banjo Team, the Variety Orchestra and Male Voice Chorus.

UNFINISHED

AMONG the curious pieces which Egon Petri, the famous pianist, will give in his recital on Monday, October 21st (Regional, 8), will be a Fantasy on two Motifs from Mozart's opera, "Le Nozze di Figaro," finished by Ferruccio Busoni from an almost completed MS.

EUROPEAN CONCERT

It is Austria's turn, on Tuesday next, to provide the European Concert in the series arranged by the International Broadcasting Union. The first part of the concert, which will be relayed by the B.B.C. at 7 (Regional), will be given by the Vienna Philharmonic Orchestra, and will include

BROOKLANDS

It may come as a surprise to many to learn that to-morrow's relay from Brooklands will be the first broadcast from the home of British motor track racing. The Mountain Championship race, which is to be described by F. J. Findon, takes place over a circuit 1.2 miles in length which has to be covered ten times, all cars starting from scratch.

The field is made up of some of the fastest track cars in the world. Last year's race was won by Whitney Straight at an average speed of 78.29 miles per hour on a course which boasts two exceptionally severe bends.

The race, which should provide plenty of material for the microphone, begins at 3.30 p.m., and Mr. Findon's commentary will be heard in the National programme.

AUTUMN SYMPHONY CONCERTS

Now that the glut of orchestral music produced by the Promenade Concerts has come to an end, the fortnightly concerts in the B.B.C. London autumn musical season will stand out as pleasant oases in a desert of less sophisticated musical entertainment.

The season opens at 8.30 on Wednesday next, October 23rd (National), with a concert conducted by Adrian Boult, who will have with him as solo artist Carl Flesch, the famous violinist, who will be heard in Beethoven's Concerto in D for violin and orchestra. The first concert performance in England of Alban Berg's "Lyric Suite" for strings will also be heard.

AWFUL DÉNOUEMENT

THERE is an amusing twist in the ending to "Congo Landing," the radio play by Horton

Giddy which will be heard by Regional listeners on Wednesday next at 9. The story, exciting and humorous, deals with the attempt of a man and a woman to set up a record for a flight from London to the Cape. The aeroplane is forced down in the African hinterland, and the unfortunate pilots, after many thrills, run into a tribal war festival.

Overcome by fatigue they decide to give themselves up, but with their last despairing gesture of submission they discover that the hostile tribes are none other than an American film unit. Moral: Things are often worse than they seem.

OPIUM

A SPLENDID opportunity to make our flesh creep came to Felix Felton and Paul Denn when the B.B.C. Drama Director asked them to evolve a radio play dealing with Thomas De Quincey. This year marks the 150th anniversary of the birth of the author of "Confessions of an English Opium Eater," in which he tells of his gradual enslavement to the drug, his torture during its domination, and, finally, his gradual recovery from its power.

The radio play "Opium Eater," which is to be broadcast Nationally on Thursday next, October 24th, at 8.30, will cover the Confessions in three episodes: Manchester Grammar School — Oxford Street—Opium. The part of Thomas De Quincey will be taken by Esmé Percy. Ann of Oxford Street will be played by Gwendolen Evans, and Mr. Gaskell by Philip Wade.

ACROSS THE BAY

MARK TWAIN'S unforgettable "The Innocents Abroad" may be conjured up to listeners who tune in Regionally at 6.30 on Thursday next for

the new feature, "Across the Bay to the Villa San Marino." Here, in a lovely café under an Italian sky, we shall light upon Mantovani and his Orchestra, and hear the local guide of San Marina endeavouring, despite handicaps, to show us round. Some of the patrons may appear to have wine not wisely but too well . . . but this is for listeners to decide.

HUMAN ORGAN FOR KENTUCKY MINSTRELS

ALREADY the Kentucky Minstrels have presented nine radio shows, and their tenth is to be broadcast on October 23rd and 25th.

Harry Pepper, who devises and produces these shows, is

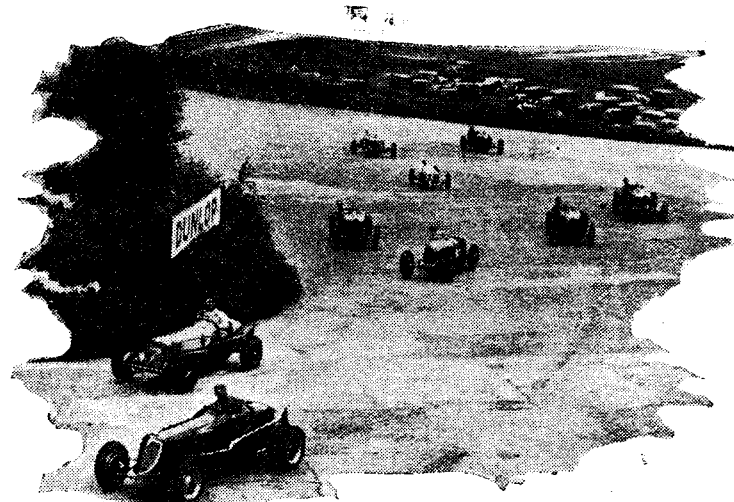

THE BROOKLANDS MOUNTAIN CHAMPIONSHIP will be described in a running commentary to-morrow afternoon. The above picture was taken during last year's exciting race, and shows the winner, Whitney Straight, taking the lead on one of the two severe bends. His average speed was 78.29 m.p.h.

giving them a different twist next week, the song medleys being related to various States in America.

One of the novelties will be a rendering of "The Lost Chord" with a close harmony accompaniment of male voices which will take the place of the organ.

Mozart's Symphony in D, conducted by Oswald Kavasta, music director of Ravag, the Austrian broadcasting organisation. At 8 o'clock the concert will switch over to gay Viennese songs, a *pot pourri* arranged by Lothar Reidinger, with the Vienna Symphony Orchestra.

Guide for the Week

at Home and Abroad

OPERA ABROAD

If all other broadcasts were cancelled and only opera remained, the listener would still find many stations operating next week, for the approach of the winter season seems to coincide with a great operatic "push."

To-night at 6.50 "La Bohème" is to be relayed



DE QUINCEY, opium eater and man of letters, whose life will be portrayed in the radio play "Opium Eater" on Thursday next (Nat., 8.30).

by Beromunster from the Municipal Theatre, Zurich. Prague follows at 7.50 with "The Voice of the Forest," an opera by one of the less familiar Czech composers, Martinu.

To-morrow (Saturday) brings an important broadcast at 7 from Budapest—Poldini's "Carnival Wedding." Budapest II gives Acts 1 and 3 at 7 and 9.40 respectively, and Budapest I the second act at 8.15.

"The Wily Widow," by Wolf-Ferrari, is Rome's operatic contribution at 7.50 to-morrow (Saturday). Radio-Paris offers an "Operatic Evening" at 8.45.

Sunday's operatic transmissions are Wagner's "Das Rheingold" (Leipzig, 6.30) and Mascagni's "Cavalleria Rusticana" (Brussels I) at 9.15.

The whole of Verdi's "Masked Ball" will be broadcast from Konigsberg at

HIGHLIGHTS OF THE WEEK

FRIDAY, OCTOBER 18th.
Nat., 8, "Bull-dog Drummond," 9.15, The Street Singer. 10.20, "Cecil Rhodes."

Reg., 7, "Tunes of the Town," 9, B.B.C. Theatre Orchestra. 10.30, Harry Roy and his Band.

Abroad.
Radio-Paris, 8.45, Opera: "Hans the Flute-Player" (Ganne).

SATURDAY, OCTOBER 19th.
Nat., 7, "Saturday Magazine," 8.30, Jack Payne's Radio Party. ¶B.B.C. Theatre Orchestra.

Reg., Verdi's "Un Ballo in Maschera," from Empire Theatre, Liverpool.

Abroad.
Vienna, 6.25, 3-act opera, "Cagliostro in Wien," by Johann Strauss.

SUNDAY OCTOBER 20th.
Nat., Victor Olof Sextet. ¶Fred Hartley and his Novelty Quintet. 9, Band of H.M. Grenadier Guards.

Reg., B.B.C. Orchestra, conducted by Leslie Heward. ¶B.B.C. Theatre Orchestra. 9, "Glasgow Revisited," by James Bone. ¶Sunday Orchestral Concert.

Abroad.
Kalundborg, 7.55, Light Classical Concert by the Radio Orchestra.

MONDAY, OCTOBER 21st.
Nat., 8, "Tally Ho!"—Stanelli's Stag Party. ¶Meet Mickey Mouse in "Who Killed Cock Robin?"

Reg., Piano Recital by Egon Petri. ¶Jack Jackson and his Band.

Abroad.
Leipzig, Munich, 9.30, Brazilian folk music, relayed from Rio de Janeiro.

TUESDAY, OCTOBER 22nd.
Nat., Harpsichord Recital, by Alice Ehlers. 8.30, "The Cat and the Fiddle" (Kern and Harbach.) Reg., 7, European Concert from Austria. ¶"Saltersgate to Staithes"—a Yorkshire itinerary.

Abroad.
Paris (PTT), 8.30, "Humour in Music," by the National Orchestra.

WEDNESDAY, OCTOBER 23rd.
Nat., B.B.C. Dance Orchestra. ¶8.30, B.B.C. Symphony Concert with Carl Flesch (violin). ¶"The Little Show"—a West-End cabaret.

Reg., Kentucky Minstrels. 9, "Congo Landing." ¶Troise and his Mandoliers. ¶Roy Fox and his Band.

Abroad.
Strasbourg, 8.30, Gluck-Berlioz Symphony Concert.

THURSDAY, OCTOBER 24th.
Nat., English Grand Marches, by the B.B.C. Military Band. 8.30, "Opium Eater."

Reg., 6.30, Across the Bay to the Villa San Marino. ¶Tchaikovsky Programme by the B.B.C. Orchestra. ¶"The Cat and the Fiddle." ¶Casani Club Orchestra.

Abroad.
Berlin, 8.10, Cabaret Programme: "What, Can't You Sleep?"

7.45 p.m. on Wednesday, while at 8 p.m. Brussels II will give a mixed Wagnerian programme. Inghelbrecht conducts the French National Orchestra in what should be a noteworthy production of Weber's "Euryanthe" at 8.30 on Thursday, from Radio-Paris.

FOR THE CONNOISSEUR

THE musical connoisseur has many opportunities of enjoyment this week. To-night (Friday) at 7.45 p.m. Hilversum relays a performance of Haydn's "Creation" by the Haarlem Oratorio Society. "Autumn in Music and Literature" is the title of Munich's programme this evening at 9.30. On Saturday Vienna offers a pianoforte recital of Brahms' music at 9.20 p.m., and at the same time on Sunday the same station promises a treat for Caruso lovers in the form of an half-hour recital of the great tenor's gramophone records. On Wednesday, Kalundborg relays a recital by the Pro-Arte Quartet of Brussels at 9.10, and on Thursday, also at 9.10, Brussels No. II will relay a carillon recital from St. Peter's Church, Louvain, by the celebrated carillonneur, M. Bigelow.

ENGLISH DRAMA FROM RUSSIA

A PERFORMANCE in English of Maxim Gorki's play, "Mother," will be broadcast at 9.5 p.m. on Wednesday by Moscow No. I.



MANTOVANI takes his orchestra "across the Bay to the Villa San Marino" for the feature broadcast on Thursday at 6.30.



AMY KONETZNI, soprano, is soloist in Austria's contribution to the European Concert series, to be relayed by the B.B.C. on Tuesday (Reg., 7).

Another English novelty will be a talk from Kalundborg at 12.10 p.m. on Sunday entitled "English Public Schools."

NATIONAL MUSIC

By far the most interesting folk programme of the week comes from Brno at 6.50 p.m. to-morrow (Saturday), to be relayed by Prague and several other European stations. It consists of Slovak Brigand Songs and Dances performed by the Moravian Peasant Club. At 7.15 p.m. Konigsberg relays a "Prussian Evening" from the Schlageterhaus.

Sunday brings an international concert from Strasbourg, the 5 p.m. programme consisting of "Folk Songs of the Nations." At 9.30 on Monday all German stations give a programme of Brazilian folk music.

Synagogue broadcasts are rare, but at 9 p.m. on Wednesday Warsaw is to give a programme of Jewish sacred music by the choir of the Warsaw Synagogue.

WINE

"GERMAN WINE" is a promising programme which all German stations will radiate at 7.10 on Monday in connection with the propaganda week which has been organised to help German wine producers. There will be some intoxicating melodies.

THE AUDITOR.

Sets of Yesterday

Salient Features of Sets of the Past Few Years

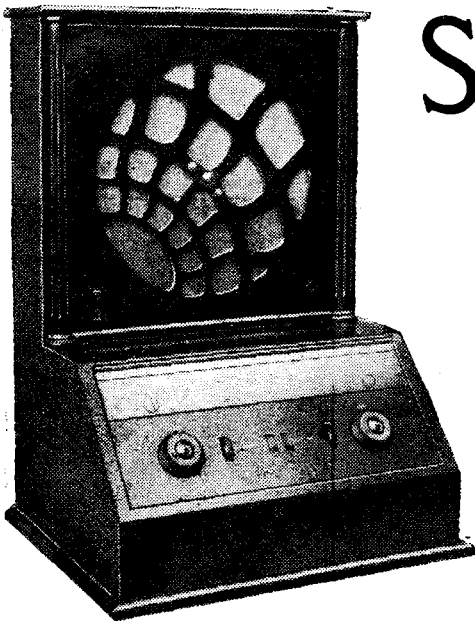

A typical receiver of 1929, the McMichael portable model

WHILST many receivers designed during the past few years are capable of quite a good performance under present-day conditions of broadcasting, only the more recent models can be expected to compare favourably with a modern set. As a general rule age can be taken as a basis for comparison, so that it would be convenient if a date could be decided on to mark the age-limit of second-hand sets that are worth while acquiring to-day.

It is by no means an easy matter to choose a definite date, since each year's Show in the past has contained some outstanding designs. The present form of set design dates back to about 1929, when the unit form of construction first became universally adopted by set makers. Yet it is extremely doubtful if this year's products would prove very satisfactory to-day, since the need for anything better than mediocre selectivity had not been obtained, nor was it demanded in those distant days.

The following year saw some interesting developments. The hitherto popular four- and five-valve portable sets were being supplanted by straight sets designed solely for use with open aerials. The gang condenser as used to-day had definitely established itself, so had the practice of individual screening of the coils. Power-grid detection was a 1930 innovation, whilst another important feature of this year's sets was the inclusion of volume controls. Actually the fitting of a volume control does not in itself constitute an achievement, but its need—and this is the important point—signifies that the sensitivity had so far improved that without the aid of reaction, overpowering volume was obtained on the local stations.

This applies, of course, to those sets embodying HF stages. The favourite method of controlling volume was to vary the screen potential of the HF valve, and in some cases this was linked up with a control of the aerial input.

The I-V-I type of set was exceedingly popular, more especially as the almost universal use of pentode output valves considerably enhanced the LF amplification.

Two HF stages with tuned intervalve couplings using screened gang condensers were employed by several makers, and needless to say, reaction was not included. The marked superiority of the 1930 sets over those of the preceding year was due principally to two main causes. On the one hand, valves had been improved considerably, and on the other serious investigation into the design of the small screened coil had led to a big improvement in this direction.

Revival of the Superhet

Of the 1930 sets the two-HF models might reasonably be expected to give moderately good results as local station sets to-day, for with the exception of some of the portables still adhering to the older style of aperiodic HF amplification, these included three tuned circuits, while a few obtained some additional selectivity by virtue of the fact that they had a built-in frame aerial whose directional properties can often be utilised to good effect.

The following year marked a notable milestone in the history of receiving tech-



A fine example of a 1930 self-contained 2-HF receiver, the Pye portable.

nique, for it saw the revival of the superheterodyne. For a number of years this circuit had been eschewed by designers, since it had acquired, perhaps not without justification, a reputation for bad quality reproduction.

ELECTRICAL features as well as age must be considered when estimating the worth of a second-hand receiver, for among each season's products of the past few years there were always several of outstanding merit. This brief review of sets of the past six years may, therefore, prove of some assistance.

The principle was not to blame—it was the application of the idea that led to the distorted output. It first came into prominence before the introduction of broadcasting in this country. Triode valves were employed in the IF amplifier, and in order to stabilise the amplifier, since often both anode and grid circuits were tuned, these stages were given a *positive* grid bias. Distortion was, therefore, inevitable.

The pressing need for higher selectivity than that of which the two-HF straight set was capable led designers to turn their attention to the superheterodyne. The use of screen grid valves, more complete screening and decoupling, one of the new developments of the previous year, enabled the desired goal to be reached. Scientific design eliminated most of the defects of the earlier superhets, and it at long last definitely established its superiority.

Selective Input Circuits

Band-pass preselector circuits were much in evidence this year, which saw also the application of the variable- μ SG valve in receivers. Control of volume could now be effected by varying the grid bias, a definite improvement over the previous method of screen potential control.

Moving-coil loud speakers were making great headway, and were fitted in many of the cheaper sets, whereas they had, in the main, been hitherto restricted to the luxury class of receivers and radiogramophones.

The circuit arrangement in some of the more expensive superheterodynes was very complete. Here is an example: band-pass input, two-valve frequency-changer, two band-pass IF stages fitted with screen grid valves, power grid detector resistance-capacity coupled to a low gain LF stage and followed by two push-pull output valves with transformer coupling. Radiogramophone fading and tone controls were fitted. It is that of an AC operated radio-

Sets of Yesterday—

gramophone in the luxury class, and the gramophone equipment included an automatic record changer. Such a set would be capable of a very good performance to-day; furthermore, many up-to-date refinements could be added without much difficulty.

Without exception, frequency changing in superhets was effected by two valves, an SG type generally being employed as the first detector, while a triode served as the oscillator.

All-wave sets were not unknown in 1931, one AC superhet had a 12- to 70-metre range in addition to the usual broadcast bands, and waveband switching was employed on all three.

The superheterodynes were essentially the luxury class, and the more popular-priced models still retained the straight circuits, though with numerous detailed improvements compared with the previous year's products. Band-pass input circuits

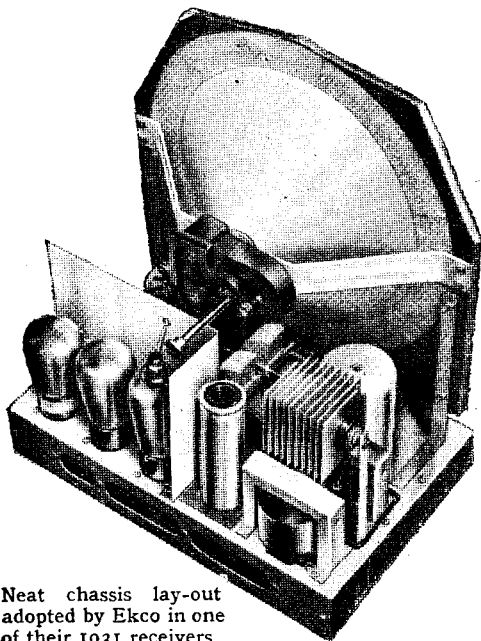

Neat chassis lay-out adopted by Ekco in one of their 1931 receivers.

were now almost universally adopted. Wavelength, or station-calibrated dials, had replaced the division scales, whilst in the mains set better smoothing was effected by the use of electrolytic condensers.

Screen-grid detector valves were popular this year in many of the straight sets, which included a local-distance switch to avoid overloading when listening to the local station. One method of achieving this was to join a resistance across the aerial coil.

There was a revival in battery sets other than the truly portable type, as the introduction of the Class "B" valve and the QPP output arrangement, for which incidentally two separate pentodes were employed, gave a greatly increased power output without a too heavy drain on the HT battery.

During the following twelve months the outstanding advantages of the superheterodyne were so well demonstrated that at the Show in 1932 almost every set maker had one or more models embodying this

circuit. The general adoption of the variable- μ HF valve resulted in sets of this year being less troubled by cross-modulation and similar interference troubles; furthermore, control of volume could be effected in a far more satisfactory manner by varying the grid bias on the HF valves. Two-valve frequency changers were still the vogue, usually preceded by a band-pass filter, and many improvements had been made in the ganging and tracking of circuits. Greater attention was given to detail. Heterodyne whistle filters were fitted in some of the straight sets, giving a cut-off at between 6,000 and 9,000 cycles, while in superheterodynes tone correction was being adopted to compensate for the high-note loss brought about by the much-improved selectivity now being obtained. A variable tone control was another feature in sets of this year.

Efficient General Purpose Sets

Several firms had given much thought to the development of the two-HF set for long-range reception. Variable- μ valves were used with three, and sometimes four, tuned circuits, though those with four circuits were in the minority. Pentode and triode output valves shared equally in popularity, while built-in moving-coil loud speakers, generally of the energised field type, in the mains models, were now standard fittings. Wave-change switches were better made, more reliable, and in most cases combined with the on-off and radio-gramophone switches, though this feature was present in the previous year's sets.

For general purpose work the 1-v-1, consisting of band-pass filter, variable- μ HF valve, screen-grid detector, and pentode output stage, was the popular type. It invariably included a moving-coil loud speaker. The parallel-feed LF transformer coupling was coming into vogue, and the improved bass response thus obtainable in an inexpensive manner was very marked in these general purpose three-valve receivers.

The following year saw the introduction of the small superhet, the forerunner of

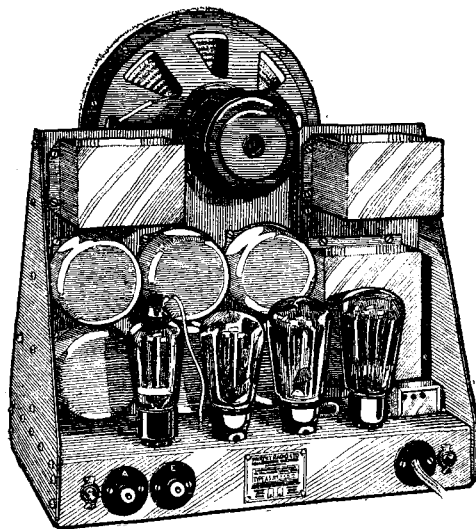

Chassis of a Murphy AC mains receiver produced in 1931.

the present-day type. By the use of a combined frequency changer and oscillator, the number of valves was cut down to four, though some had five. In the short space of twelve months the superhet had come right to the front, for high selectivity was being demanded, and the many improvements in superheterodyne

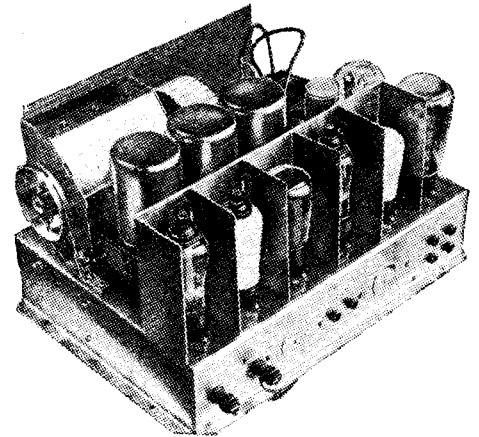

Very complete screening was adopted in 1932 as shown by this R.G.D. superhet chassis.

design by now effectively placed this type of set in a dominant position.

Like all other new developments, automatic volume control first made its appearance in the more expensive models, most of the six-valve and larger superhets embodying this feature. Delayed AVC was employed using a duo-diode-triode detector valve, and a very few embodied QAVC. Needless to say, variable- μ valves were now almost universally fitted in HF and IF stages.

The single valve frequency changer did not take the form we know to-day, nor was it generally adopted, and the two-valve arrangement still found many adherents. Some makers employed a Pentagrid, others an HF pentode, combining the functions of oscillator and first detector, but as the majority of superhets still had six or more valves two of these were allotted to frequency changing, generally taking the form of a variable- μ HF valve as first detector and a triode oscillator. The former was often included in the AVC circuit.

Stabilisation

Receiver design was now beginning to take the form it follows to-day, a duo-diode-triode valve forming the second detector valve, giving AVC and providing a stage of LF amplification with a manual volume control for the input to the triode portion.

Inter-station noise suppressors, taking the form of a switch that de-sensitised the set by applying a little extra grid bias to some of the HF valves, were among the refinements found in the 1933 sets, though, as mentioned already, true quiet automatic volume control was included in some of the more advanced designs.

The small superhets of four and sometimes five valves invariably included a band-pass aerial filter, a combined detec-

Sets of Yesterday—

tor-oscillator, and one IF amplifier and, as a rule, had six tuned circuits. In the larger models, on the other hand, it was not unusual to find a stage of HF amplification at the signal frequency followed by a two-valve frequency changer and two IF amplifiers, and with eight and possibly nine tuned circuits, if a band-pass input filter was included.

The smaller models were evolved to meet the requirements of the average listener desiring something a little more selective than the straight sets of the previous years, so that they virtually supplanted the three- and four-valve straight sets which, at the best, had but four tuned circuits.

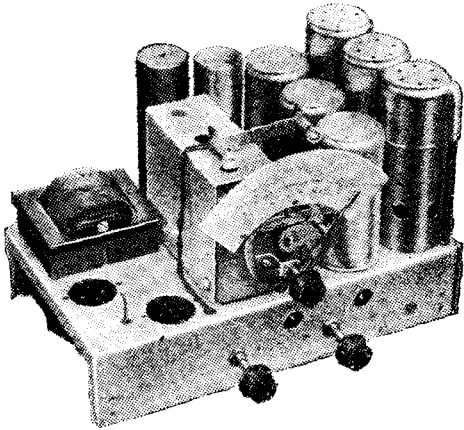

G.E.C. five-valve superhet, a 1933 product.

An improvement effected this year was the inclusion of tone correction circuits, for hitherto a common practice was to take advantage of the characteristics of the pentode output valve to compensate for high-note loss in the HF circuits. Generally it was left to the listener to adjust the tone to his liking, and a control was included for this purpose. Partial remedies were found for such of the earlier defects as second-channel interference and break through of commercial stations working on, or close to, the wave length of the IF amplifier.

Small Superheterodynes

During 1934, the small four-valve (excluding AC rectifier) superheterodyne developed very rapidly and came to be regarded as the popular, or general-purpose, type of set. Greater use was made of multiple valves, and the 1934 four-valve superhet was virtually equivalent, so far as the number of individual stages it included, to the six- and seven-valve models of the past two years.

Heptodes and similar styles of frequency changer had come into general use, so had the duo-diode-triode, but in addition, a new valve, the duo-diode-output pentode, made its appearance leading to a still further reduction of apparent, though not actual, valves in the set.

Hitherto receivers were classified by their number of valves, and one could judge, within certain limits, what the set would do, namely, whether it fell in the long-range category or was best suited for

local and medium-distance reception. But now the number of valves ceased to convey any indication of the set's capabilities, for a four-valve model of this year was virtually equivalent to the six- and seven-valve sets of the past. The number of tuned circuits was the only real criterion, so far as selectivity was concerned, but this method of adjudication needs to be applied with discretion when comparing this and the past two years' products, for many improvements had been effected in coils, condensers, and, perhaps the most important of all, in the lining up and tracking of circuits. The wide use of iron-cored coils in HF and IF circuits constituted a marked advance.

These small superhets invariably included a band-pass input circuit though often the "band-pass" was a misnomer since, in order to enhance the selectivity, optimum coupling giving a single-peak response was adopted. One IF stage with four tuned circuits followed this frequency changer, then came detector and AVC, and invariably a pentode output valve. With good coils these six tuned-circuit-receivers provided good selectivity, while the pentode served to compensate for much of the high-note loss in the HF circuits. They were, and still are, eminently suitable as general-purpose medium long-range sets.

Inter-station noise suppressors were becoming commonplace this year, though the automatic variety, or QAVC, was found mainly in the more expensive sets, the popular-priced models including a switch for desensitising the set and, but for the fact that it was manual operated, it served much the same purpose.

A few manufacturers had commenced to include variable selectivity in their larger sets, this usually taking the form of a control for varying the band width of the IF amplifier in much the same way as is adopted in those present-day receivers that embody this feature.

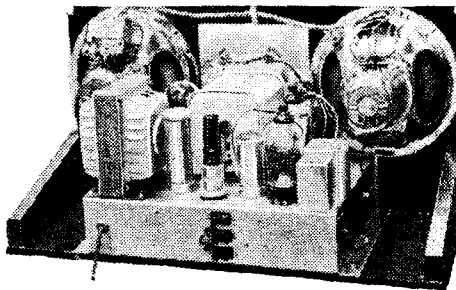

C.A.C. Austin receiver of 1934 fitted with dual loud speakers.

As the small superhet developed, the popularity of the straight three-valve set waned, and although some outstanding examples were still available, it was mainly in the new universal AC-DC sets and in battery models that this circuit retained its adherents. The demand for better selectivity with the passing of the years, slowly but surely led to the abandonment of the straight circuit for all but the cheaper of the mains receivers.

The trend of design had by now taken on the completion of modern practice, and

further progress was mainly confined to detail improvements and the practical application of new ideas, and this line of development is being pursued at the present time.

Short-wave Broadcasting

A READER of these notes, in a letter recently received, asked whether it was possible to devise a short-wave receiver that would bring in "just a dozen" stations with programme-value comparable with that obtained on medium waves with a good modern receiver.

This set the writer working on the matter, and, in consequence, the last fortnight has been spent in company with (a) a good modern receiver, and (b) a fairly good two-valve short-wave converter.

It is fairly safe to say that there is, frankly, no single short-wave station that gives equal programme-value with the local medium-wave station. There are, however, at least a dozen that are every bit as good as, say, Hamburg, Budapest and Hilversum.

On a careful list made during the fortnight, the following stations have emerged with three asterisks against them, signifying "programme-value perfect when transmitting": W2XAD, W8XK (19 metres); W8XK, 2RO, DJD (25 metres); 2RO, W1XK, DJA, W2XAF, PRF5 (31 metres); YV6RV, HJ5ABC, W8XK, YV2RC, W3XAL, OXY, W3XAU, W4XB, COC (49 metres).

One short of a score, it will be noticed; and well over another score of stations have been honoured with two asterisks, meaning "perfect except for fading or interference at times." The "one-star" stations were too numerous to list, these being perfect except for fading and interference at most times.

It seems safe to assume from this that our reader who is content with a dozen stations with real "P-V" need only build himself a small converter, since, presumably, he has already a modern broadcast receiver with which to work it.

The one on which the listening described above was done consisted of a heptode frequency-changer preceded by an HF stage. The controls were not ganged, but might have been without the slightest difficulty. Searching was simplicity itself, thanks largely to the excellence of the broadcast receiver. One certainly appreciates AVC and an apparently unlimited supply of audio output when one's short-wave listening for the previous fortnight has been carried out with a homely two-valver.

The broadcast receiver, incidentally, was set throughout to give an intermediate frequency of roughly 525 kc., and the tuning control made a pleasant fine-tuning adjustment for the short-waver. Has this tip been expounded before? It is certainly worth knowing.

A third Australian is reported as transmitting regularly, in the shape of Melbourne, VK3ME, on 31.55 metres. This station has been heard between 10 a.m. and noon on Sundays, and has also been reported on a week-day at 7.30 a.m., sharing the 31-metre band with VK3LR (Lyndhurst), which, of course, works regularly at that time during the week.

MEGACYCLE.

The Four Cardinal Points

Plain Facts About Sensitivity, Selectivity, Quality and Power

By "CATHODE RAY"

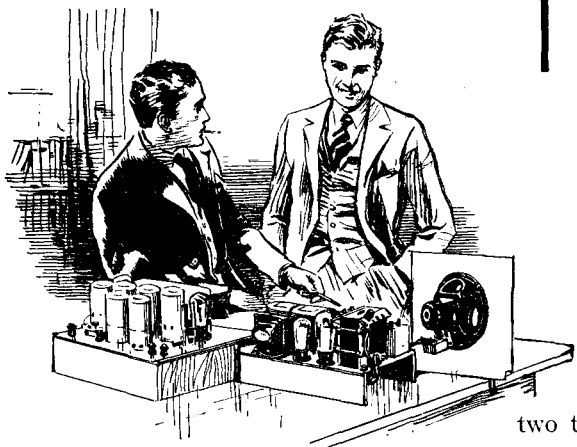

IN "1066 and All That" the authors recognise the popular desire for simple comprehensive appraisals by classifying everything into Good Things and Bad Things. While this may adequately describe matters that are remote enough not to concern us very directly, the method is too summary for the complex affairs of present-day life.

In a very few cases it may possibly be a fair and complete judgment to say "That is a bad set!" but it is difficult to imagine anybody with any interest at all being content to be informed that this other one is "good." It is natural to inquire in what respects it is good. Salesmen apart, who would hold that any particular receiver was perfect on every basis of judgment? It might be possible to give unstinted praise of one virtue, yet to admit that such a high standard had been reached at the expense, at least to some slight degree, of another. A second critic approaching from some other angle would distribute his praises differently.

There are endless "points" that can be judged in a wireless receiver, but four stand out as fundamental. These are: Sensitivity, Selectivity, Quality and Power. They are so much the ABC to the "old hand" that he forgets he ever had to learn them, until he realises with a sudden shock that to other people they are a source of confusion. One, indeed, is ambiguous; "quality" might be taken as a general term covering all merits. But the layman persists in describing as a "powerful" set one which has a long range. Selectivity, too, is often confused with station-getting capabilities. So this time I am going to be thoroughly elementary and explain what is understood technically by these four terms and their aliases.

Loud-speaker Efficiency

First, Power, which is taken to refer to the maximum electrical power that can be drawn from the receiver for producing the programme of sound when it is fed to the loud speaker. As it is the sound, rather than the power that causes it, that is of interest to the listener, and as the loud speaker is usually worked permanently in connection with one particular set, it is customary to regard the

two things as more or less the same. A powerful set can give a large volume of sound. But it must never be forgotten that if we substitute a loud speaker that is less efficient—i.e., that requires more power for a certain volume—volume will be reduced even although the power is just the same.

The term "output" is sometimes used for "power," and more rarely but quite correctly for "volume." All three of them can be used to mean the amount that is actually being delivered at any given moment; but, of course, that may be (and fortunately often is!) quite different from the utmost capabilities of the receiver, which is the thing we are discussing just now. To make it quite definite we ought to say *maximum* power; but the abbreviated term is usual when the meaning is clear. Another thing; it is generally understood that this maximum power conforms to a certain standard of distortionlessness; a mere riot of sound does not qualify.

"Powerful" Single-valve Set

Now—and this is where novices go wrong—power does *not* depend on the number of valves in a set. It is possible to have a single valve set of enormous power, or a 10-valve set with very little. The power output depends on the type of valve used in the last, or output, stage; and on the HT current and voltage that is available for it; and also, of course, on the way the designer and constructor have made use of these things.

This, then, is really the first part of a receiver to be designed. Generally there is no purely technical advantage in limiting the power—nobody is compelled actually to use it all, for that might constitute an actionable nuisance; but, like a motor car, the more power there is at command the more smoothly and pleasingly it works at lower outputs. Also like a car, the more it costs; and that is really what settles it in both cases. Battery power is so expensive that few can afford to splash it about; it is like running a car on eau-de-Cologne.

Another point: if somebody invented a very much more efficient loud speaker than those now in use, we could do with much less power.

Having settled the sound-making capabilities, we find ourselves with one valve, or perhaps a pair working in push-pull

combination; and there is so little amplification (the greater the power of a valve the less its amplification, as a rule) that the range of reception is limited to a few miles at most. As such a state of affairs is not likely to give satisfaction, we have to consider the second point: Sensitivity.

A great advance in sensitivity is obtainable by prefixing another valve, one of sufficiently high amplification, and connecting it in such a way as to make good use of its capabilities (technically called characteristics). If that is not enough, we stick another in front of that; and so on. This is where there is plenty of scope for ingenuity, in connecting and coupling, in deciding whether to amplify at low or high frequency or some other sort—but there is no time to go into all that just now. Sufficient to know that by using enough valves in the right way the sensitivity can be made great enough to receive almost any station in the world.

The troublesome thing is that the receiver will be bringing in almost *every* station in the world—at once! So the third problem is Selectivity. It is vital to realise that selectivity is an absolutely separate and independent thing from sensitivity. It is usually most important when the sensitivity is large, but there is no inevitable relationship. It is rather like a pair of glasses or a telescope, which may be of low or very high magnification, but in either case it is important that it should be able to focus or resolve objects clearly without overlapping.

Power and sensitivity are both quite easy to measure and compare, but selectivity is a much more complicated business and nobody has yet produced a universally acceptable standard of measurement. Selectivity may mean many or few valves, but more often many; it is not at all remarkable for a valve to be used for increasing selectivity with no increase of sensitivity at all (though strictly it is not the valve but the connecting components that are responsible for the selectivity).

Faithful Reproduction

Having got the choice of as many stations as we want, and as loudly as we can afford, and no overlapping or confusion, there may still be a major cause for dissatisfaction—Quality.

In official circles this does not refer to the nature of the cabinet-work or polish, nor to the "class" of the programmes. It refers to the faithfulness with which the broadcasting is reproduced by the receiver. Some people, cynically recognising that the best receiver is powerless to make a silken purse out of a sow's ear, prefer to use the term *Fidelity*. The sound

The Four Cardinal Points—

coming out of the loud speaker may be true to the original even if the quality appears to be poor.

However, keeping to the commonly used expression, *quality* means freedom from distortion. There are various sorts of distortion—this is not the place for a comprehensive treatise on that interesting subject—and they are not excluded by adding any further valves or other components. It is not uncommon for accessories to be offered for sale with the claim of taking away all distortion from any set, but these are on exactly the same footing

as pills which, it is asserted by the vendors, remove all pain from any sufferer. The percentage profits, also, are likely to be of the same high order. The only way to ensure good quality is to design and maintain the receiver as a whole with this object in view.

Some aspects of quality can be measured fairly easily, and others—particularly those relating to the loud speaker—are still the subject of much technical discussion. In a sequel I will try to make milliwatts, microvolts, and decibels—the lbs. and ozs. of all this work—a trifle less recondite.

Random Radiations

By "DIALLIST"

Is there a Best Set?

LIKE myself, you are probably asked not infrequently by friends and acquaintances to tell them which is the best receiving set. I don't know whether you have found an answer to the question, but I confess that I am still without one. There are heaps of things which add to the difficulty of finding a reply that will satisfy the enquirer and not leave him with the impression that you are making use of evasion to cover up ignorance! First and foremost, individual requirements differ very considerably. One man is quite content to have the local stations at their best, but he wants a set that will provide "realistic volume," which means an output of the order of 10 watts or so. Another desires to be able to receive anything that is going on the Continent when he feels so inclined. A third make a strong point of economy in running costs. . . . And so it goes on. When you come to the question of "tone," tastes differ vastly, and then there is the problem of appearance, for in cabinets one man's (or woman's) thing of beauty is another's eyesore.

Reliability Foremost

One is probably not very far wrong in saying that at any given price between, say, ten and twenty guineas there are a dozen or more sets of different makes which are equally good as regards sensitiveness, selectivity, effectiveness of automatic volume, ease of operation, and so on. With sets that may be equally good performers, the most important factors in my humble view are reliability and good after-sales service. I would even go so far as to sacrifice, if need be, something in the way of performance if by so doing I could make sure of obtaining a trouble-free receiving set.

A reputation for reliability is, I believe, going to influence buyers more and more in making their final choice. This is as it should be, for the set which keeps steadily to its work and runs one into little or no expense for repairs is a precious possession. On the other hand, a receiver which is constantly developing defects, great or small, is something more than a nuisance. The adoption by many manufacturers of a guarantee extending for ninety days only will probably do a great deal towards weeding out unreliable sets. Knowing that the cost of all repairs must come out of his own pocket from the end of the three months' guarantee period onwards, the

intending purchaser is likely to do what he can to make sure that he is investing in something dependable.

A Good Piece of Work

THOUGH I am not a Soccer fan myself, having been brought up on the other kind of football, I welcome the news that, after all, the commentary on the Final Cup Tie is to be broadcast. The opposition came largely from the smaller clubs, who found that their gates were seriously affected by the broadcast. This difficulty has been overcome by the decision to time the kick-off in the Final for 2 o'clock. Some clubs will start their matches at a later hour than usual; others are talking of installing loud speakers on their grounds so that spectators may hear the commentary. Whether the B.B.C. will relax its usual rules about "publishing" broadcasts so as to allow this I don't know; but in any case it should be possible for most clubs to arrange matters that their attendances are not greatly reduced by the broadcast of the commentary.

There is now hardly a big sporting event which we cannot follow with the aid of our wireless sets. The Grand National, the Derby, the Boat Race, the Test Matches, the tennis championships, motor and motor cycling races, golf championships and important football matches under both codes can be followed in imagination in our own homes by the help of the loud speaker.

A Valve War

IN the United States there is raging at the moment the Battle of the Tubes. One firm stands alone in sticking to the glass-bulbed valve; all others of importance have adopted valves of the metal type which were described some time ago in *The Wireless World*. When they decided to adopt the metal tube these firms launched a mass advertising attack upon the one which still pinned its faith to glass. As the latter happens to be about the biggest of the lot, it is well able to look after itself, and the warfare has developed along the most interesting lines. It is regarded by the lay papers of the U.S.A. as a gold mine for "sensations and thrills." One side brings out an advertisement telling of the enormous advantages of metal. *First round*

goes to metal tubes, scream the headlines. This is countered by an extraordinarily clever announcement making point after point for glass bulbs. *Glass tubists land body punch*, yell the lay papers. If you can get hold of one or two of the American weeklies or monthlies you will find the Battle of the Tubes, as portrayed in their pages, a real source of joy!

Counting the Cost

SURPRISING as it may seem, I still hear from a good many people who have formed the idea that an all-mains receiving set will make a considerable addition to their lighting bills. As readers know, the current consumption for a mains set runs only from 10 to 15 watts per valve on the average, and the great majority of such receivers require no more current than the kind of bulb that one uses in passages or bedrooms. You can do good service to wireless by exploding these absurd notions when you come across them. There are many similar quaint notions about wireless, and many a man is deterred from installing a receiver because of some utterly erroneous idea that has become fixed in his head. I could mention a round dozen of such queer notions without difficulty—but doubtless you can make an equally long list from your own experience.

The Indirect Method

THE Bell Telephone Company of America compiles every day graphs showing the "load" on its lines at all hours. Some time ago those whose business it is to study these graphs were surprised to find a very marked and sharp dip in the daily curves between 6 o'clock and 6.15 in the evening. As this had previously been a normally busy period, no explanation could at first be found for the fact that so little use was made of telephones in that quarter of an hour. Then somebody saw in a flash what is undoubtedly the correct explanation. Amos and Andy, America's most popular pair of back-chat entertainers appear before the microphone every evening at that time. Everyone was engaged in listening to them and so telephones were disused. The percentage of sets in use at that time must be very high. No other turn broadcast is sufficient to affect the telephone load curves noticeably.

A Gadget Badly Needed

AN enquiry that often comes my way is whether there is any mains or battery set of good performance with which it is possible to use a pair of headphones so that a deaf listener may be able to appreciate the programmes which he cannot hear properly by means of the loud speaker. So far as I know there is only one such set, and this is made specially for deaf people. There seems to be an inherent difficulty about making and marketing a small apparatus with independent volume control which would allow a pair of telephones to be used with the aid of the loud speaker extension terminals or sockets that are provided on so many sets nowadays. There would, I am sure, be a considerable demand for it, for there are large numbers of homes in which something of the kind would be a great boon. It would, of course, be necessary to make the apparatus completely fool-proof, but there should not be any great difficulty about this.

Silencing the Set's Loud Speaker

Speaking of the use of headphones and of extension loud speaker terminals reminds me of one improvement that I would very much like to see more generally adopted in receiving sets. This is a switch enabling one to bring into action at will the loud speaker in the set alone, or the extension loud speaker alone, or both of them together. Many people who have extension loud speakers find it rather a nuisance not

to be able to silence the one built into the set when the other is in operation. There are, of course, times when both instruments are needed, and it is always possible to silence the extension loud speaker by disconnecting it. Until recently very few sets incorporated any means of cutting out the built-in loud speaker when it is not required, and the idea involves so little in the way of complications that its general adoption seems to be long overdue.

records. It appears to me that a more useful system would be for records to be manufactured with a different composition on the reverse side, in which case they would be equally useful for either type of instrument. T. CUTHBERTSON HILL.

Newcastle-on-Tyne, 2.

Contrast Expansion and all That

"CATHODE RAY" mentions "an extra 'effect' that can in any case be switched off if not required."

The time seems ripe for "Automatic Gadget Control" (AGC to give the requisite ambiguity). When anyone wants to settle down to a short period of serious listening this in one operation, possibly by a time switch, cuts out the selectivity, puts in the local, and generally tidies things up.

Quite seriously, it would be a useful experiment to have on one station a programme radiated as suggested by Mr. D'Orsay Bell, the loudness modulation coming from a second, which latter could be modified on reception in any desired manner to control the output level. If nobody used the pair of stations there are a few engineers who would be glad to have the constant *f.* transmission (the comparatively slow modulation being easily dealt with by AVC) for all sorts of useful little RF measurements. The constant level station should be quite popular with all those who like a wireless background to all conversation, and others could have as much *pp.* as they liked without any disturbing *forte.*

More seriously still—when are we to have the constant AF transmissions?

Ware, Herts. GERALD SAYERS.

Letters to the Editor

The Editor does not hold himself responsible for the opinions of his correspondents

If Power Stations were Bombed?

WITH reference to the Correspondence on crystal sets, there is an aspect of the subject which I have not yet seen mentioned.

The B.B.C. have taken most elaborate steps to ensure against breakdown of the power supply. Besides the normal supplies, they also have their own generating plants, so that failure to broadcast from this cause may be discounted to a minimum. The time when these additional facilities would be likely to be called into use would be during a time of national crisis, such as riot, civil commotion, or war, when one or more parts of the grid system might have been put out of action. It would then be most useful if the Government were still able to disseminate news and instructions—as, in fact, occurred during the National Strike in 1926.

It is, however, no good sending out messages if no one is able to receive them. Although there are numbers of battery receivers in use, it is safe to say that the vast majority are mains-driven, and, if the B.B.C.'s external power supply were cut off, the probability is that most listeners' sets would be "out of order" at a most critical period.

Now, such a period would be of very rare occurrence, and it would be unreasonable to expect people to keep a battery set, complete with ready-charged batteries, in case it was needed. But a crystal set would present no such difficulties, and I suggest that every household which has a mains set should be encouraged to have a crystal set as well.

L. C. M. CAVE.

Practical QAVC Circuits

THERE are difficulties in accepting the explanation given by Mr. J. H. Reyner of the QAVC system which he illustrates in Fig. 1 of his article in the issue of September 27th.

He attributes the suppression of weak and noise-ridden signals to the reduction in gain of a triode when the grid bias is zero and the anode voltage low. Now the gain of a valve is very closely a function of the "lumped voltage," i.e., the anode volts plus $\mu \times$ (grid volts). As under normal full amplifying conditions a negative bias is used, and μ is quite a large number—probably about 35—the lumped voltage is quite low, and may well be of the same order as, or even lower than, that in the suppressing condition.

Even if one grants that the anode voltage is very low indeed, at worst the gain will still be an appreciable fraction of that under normal conditions, and will slide gradually from one state to the other as the signal increases.

This is at variance with the performance actually shown by Mr. Reyner in his Fig. 2, where the gain is nil for signals up to a certain strength, and then suddenly becomes large.

One does not have far to look for the true explanation of this result. The grid of the muting valve V2 is made positive, causing a cathode-grid impedance which is negligible compared with the 1.5 megohms in series externally. The whole of the bias thus appears across this resistance, and one-third of it is applied as a negative bias to the signal diode. Thus complete suppression of signals up to this voltage is obtained.

Bromley, Kent. M. G. SCROGGIE.

I MUST thank Mr. Scroggie for an explanation of the operation of the first circuit in my article which had escaped me. While practical tests show that the gain of the valve in question is considerably reduced, the suggestion advanced by Mr. Scroggie does undoubtedly give a happier explanation of the observed effects.

My investigation was, of course, primarily concerned with the results of the various arrangements, which still remain valid.

Boreham Wood, J. H. REYNER.
Herts.

Song-Plugging

ONE of our leading daily papers recently published an article on song-plugging and called attention to the persistent repetition of the same material two or three times daily for weeks. The article referred to the B.B.C.

To try to get away from it many listeners tune-in on Sundays for the Continental concerts, only to have the same old stuff inflicted on them again. Why the Continental people do this I cannot imagine. There are on the market thousands of gramophone records of good lively music, etc., that would be greatly appreciated, so why the broadcasting stations confine themselves to about twenty recent additions and repeat them till they die of sheer exhaustion is a mystery.

HARRY McCALLA.

Stockwell, S.W.9.

Record Changers

I WAS interested in your article in reference to the above. The manufacturers of records do not appear to me to cater sufficiently for customers with record changers. It is only for compositions requiring three or four records that provision is made for automatic coupling, and then one series is used so that it is still necessary to reload after playing three or four records. To use a record changer for the usual double-sided record it is necessary to duplicate the

THE RADIO COMPANION**An Interesting Pocket Portable**

In next week's issue a description will be given of how to make an extremely portable phone set which can be conveniently carried in the pocket and is, therefore, suitable for use on many occasions when a larger set would be impracticable.

An illustration of the receiver with headphones is shown to give an idea of the small size. The circuit is quite straightforward, and consists of a detector with reaction and

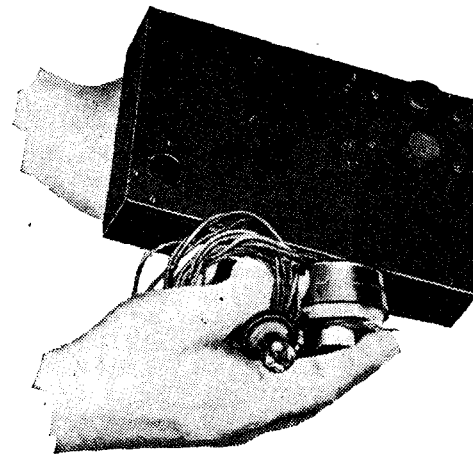

two LF stages. The set embodies a frame aerial, and good reception may be counted upon up to a range of some 50 miles from a B.B.C. station.

The principal components required are:—3 midget Hivac valves, types XD, XL and XP; a 33-volt Drydex HT battery, type X81; 2 Bulgin midget transformers LF33; a 3-valve holder unit by Lectro Linx, whilst 2 pre-set condensers are used for tuning and reaction respectively. The LF accumulator is the Exide Gel-Cel No. RDJ1.

UNBIASED

Stone-age Methods

IT is astonishing how slow are our great captains of industry to take advantage of the benefits to be obtained by adopting modern inventions. Apparently this always has been the case; there is the classic story of the inventor of the telephone hawking his idea from office to office, while it is commonplace knowledge that it is a matter of great difficulty to induce savage tribes to exchange their bows and arrows for the benefits of civilisation in the form of poison gas and submarines.

A very striking instance of this sort of thing came my way the other week when I was a privileged spectator at a large conflagration which had broken out in one of the less fashionable parts of the metropolis. Scattered among the crowd were representatives of the Press scribbling away in their old-fashioned notebooks,



Properly equipped for witnessing the fire.

while a little way along the street was a long queue of journalists waiting patiently in front of a solitary telephone booth, inside which a woman was carefully powdering her nose as she chattered to her friend over the wire. Not a single reporter thought of adopting modern and up-to-date methods of getting the news red-hot to his office, and yet it was not for the lack of means of communication, but merely hidebound conservatism in matters scientific which brought about this sorry state of affairs.

The remedy is the use of a little imagination on the part of these scribes of the lay Press, although, goodness knows, they ought to possess enough of that, judging by their writings. Needless to say, I was myself properly equipped for witnessing the fire, having on my back my old army pack in which I had installed an ultra-short wave transmitter for the purpose of giving Mrs. Free Grid the very latest details of the fire. There was not the slightest reason why the Press representatives could not have been similarly equipped, and thus have been able to transmit really hot news direct to their respective newspaper offices instead of

By FREE GRID

employing the ordinary telephone and similar Stone-Age methods of communication.

Only One Record

I HAVE received many letters both from wireless manufacturers and from ordinary human beings as the result of the appeal I published a little while ago for all automatic record changers to be fitted with a lever whereby the automatic mechanism could be cut out when it was desired to play one record only.

Certain manufacturers of these devices have written to say that such an arrangement would, in any case, be redundant, as any person who wishes to play only one record need only put it on the automatic mechanism in the ordinary way and all will be well.

It is quite evident that my informants number naught but plutocrats among their customers and do not condescend to associate with such people as my readers, many of whom are not very far from the bread line and are therefore compelled to go in for the new nine-inch records which have recently made their appearance.

With regard to the other side of the question, I have had plenty of correspondence from ordinary readers who have invented the improvement to which I have referred and more also, but in every case when they have called on manufacturers with their plans and specifications they have had a scurvy reception, being treated just as though they were members of the ordinary set-buying public.

I should have thought that the Inventors' Exhibition would have been crowded out with devices of this nature, but during a personal visit I could find only one. Even this did not quite fulfil my requirements, however, as it tackled the problem of record changing in a new way altogether, whereas I want a simple alteration to the existing single-sided eight-record changer. Actually, the improvement I want is very simply carried out, and if I do not receive a better idea in the course of a post or two I shall submit my own notions to the manufacturers and see what sort of treatment I get.

Hope for the Married

FOR many years now I, in company with other married men and fathers of families, have striven valiantly against unequal odds to secure perfect broadcast

reception. In spite of many reverses I have never lost heart, and I am pleased to say that as a result of my pertinacity I hope to be in a position shortly to give you a circuit diagram and full constructional details of "The Married Man's Five."

As a family man I have always been filled with bitterness at the callous manner in which leading set designers occupy themselves with relatively unimportant little problems like QAVC, high fidelity, etc., whilst studiously ignoring the real problem of turning out a set which will make itself heard above the pandemonium of extraneous noises in the average home due to the chattering of women, the screaming of children, and other domestic cacophonies. Of course, merely to design a receiver with a super-powerful output is no solution to the problem, for, strange though it may seem, there are occasions when comparative peace reigns in the home, usually when the children are at school, and the womenfolk are attending a mothers' meeting.

Now nobody would think of attempting to combat fading by using a super-sensitive set, that is, a set which was sensitive all the time, for the volume of it would be intolerable on those occasions when fading was temporarily absent. I have always thought that, just as AVC enables the sensitivity of a set to keep step with fading, so also there should be something applied to the low-frequency portion of the receiver to cause the volume of a loud speaker to rise and fall in accordance with the noise level in a room at any given moment, and I flatter myself that I have at last nearly solved the problem.

Like all great inventions it is comparatively simple, merely consisting of a microphone, or rather several of them, disposed about the room to pick up the noise of female chatter. The variations

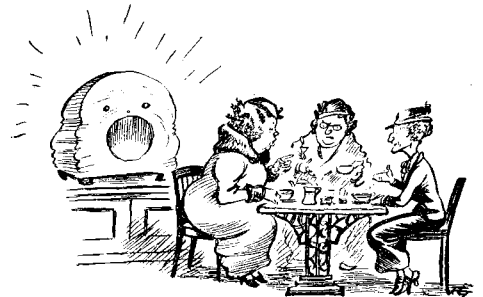

Will make itself heard above the pandemonium.

of sound picked up are caused to operate a simple electronic volume control associated with the output stage so that at all times the degree of volume actually reaching the ear is practically the same, irrespective of whether a conversation is being carried on in the room or not.

There is only one snag which I have to overcome before my invention is perfected and ready to be put before you, and that is the evolution of a device to prevent the volume of the loud speaker being affected by its own output, so causing it to throttle itself.

The Wireless World

THE PRACTICAL RADIO JOURNAL
25th Year of Publication

No. 843.

FRIDAY, OCTOBER 25TH, 1935.

VOL. XXXVII.

No. 17.

Proprietors: ILIFFE & SONS LTD.

Editor:
HUGH S. POCOCK.

Editorial,
Advertising and Publishing Offices:
DORSET HOUSE, STAMFORD STREET,
LONDON, S.E.1.

Telephone: Hop 3333 (50 lines).
Telegrams: "Ethaworld, Sedist, London."

COVENTRY: Hertford Street.
Telegrams: "Autocar, Coventry." Telephone: 5210 Coventry.

BIRMINGHAM:
Guildhall Buildings, Navigation Street, 2.
Telegrams: "Autopress, Birmingham." Telephone: 2971 Midland (4 lines).

MANCHESTER: 260, Deansgate, 3.
Telegrams: "Iliffe, Manchester." Telephone: Blackfriars 4412 (4 lines).

GLASGOW: 26B, Renfield Street, C.2.
Telegrams: "Iliffe, Glasgow." Telephone: Central 4857.

PUBLISHED WEEKLY. ENTERED AS SECOND CLASS MATTER AT NEW YORK, N.Y.

Subscription Rates:
Home, £1 1s. 8d.; Canada, £1 1s. 8d.; other countries, £1 3s. 10d. per annum.

As many of the circuits and apparatus described in these pages are covered by patents, readers are advised, before making use of them, to satisfy themselves that they would not be infringing patents.

CONTENTS

	Page
Editorial Comment	435
Does Broadcasting Serve Britain?	436
Current Topics	439
The Radio Companion	440
The Small Superheterodyne	444
Re-creating an Old Set	447
The Listeners' Guide for the Week	450
Unbiased	452
Loud Speaker Overhauls	453
Milliwatts, Microvolts and Decibels	454
New Apparatus Reviewed	456
Broadcast Brevities	457
Random Radiations	458

EDITORIAL COMMENT

When You Buy

Importance of Your Choice of Dealer

MANY people are inclined to think that when they have once succeeded in making up their minds what set they want to buy their troubles are at an end and they only have to go out and buy it.

In an ideal world this might be so, but certainly in our radio world it is not the case. Whatever care a radio manufacturer may take in the production and testing of a receiver, little things crop up after purchase which need attention; it may be matters due to improper installation or troubles arising from defects in the set itself, due to a fault in a valve or one of the component parts.

When you choose a doctor you are probably rather particular because you know that at any time you may have to depend upon his skill to maintain your "chassis" in good order and even to ensure a reasonable chance of long life.

In the choice of a doctor you have the advantage that you know he is qualified because he could not practise unless he were.

In the radio industry, when you buy a set you expect service from the source from which you obtain it, but unfortunately you are left to find out for yourself, before you buy, whether the dealer who supplies you is qualified technically, and, what may be even more important, that he has acquired a reputation, which will be your guarantee that he will treat you fairly.

The radio industry is too new for it to have been possible, as yet, to establish a standard of qualifications for radio dealers, with the result that almost anyone can start a shop and sell

wireless sets. This is why it is that one hears so many complaints of incompetence in servicing after purchase, whilst in far too many cases dealers exhibit no interest whatever in a set after they have sold it.

The only remedy seems to be to encourage the public to discriminate as carefully in their choice of "where to buy" as in "what to buy."

Some manufacturers appoint their own dealers, and where this is done the purchaser can feel pretty safe in buying there because the manufacturer's own interests are at stake and he would not appoint a representative without first finding out all about him and satisfying himself as to his qualifications and reputation.

Value of a Reputation

Electrical and other firms of long standing which have already acquired a reputation in some other branch of industry may be counted upon in most cases as reliable radio dealers, even if they do not specially represent any particular manufacturer, because they would not take risks with their reputations but would see to it that they were properly staffed and equipped to handle radio before embarking upon a new enterprise.

A year or two ago it might have been difficult to find the right dealer, but to-day the standard is much higher than it was and there are really plenty of dependable and satisfactory sources, though not always the most prominent, from which to buy without taking risks.

It is very important that the radio industry should be in capable hands and we should try to give all the support we can to those dealers who are competent and are taking their business seriously and should avoid, and advise our friends to avoid, buying from unqualified firms

Does Broadcasting Serve

A REGIONAL TOUR
OF
INVESTIGATION

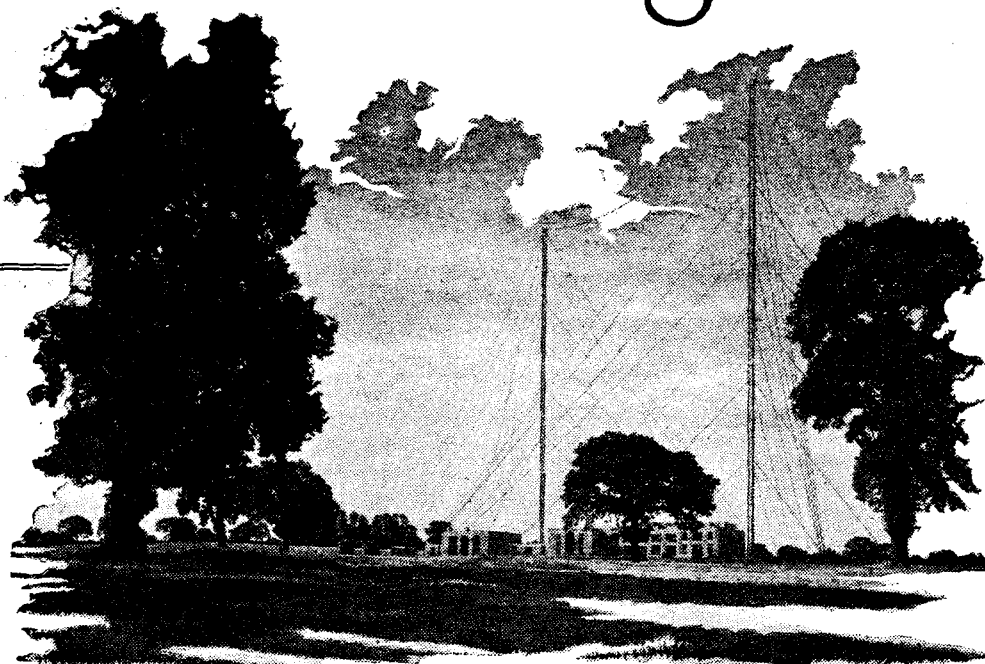
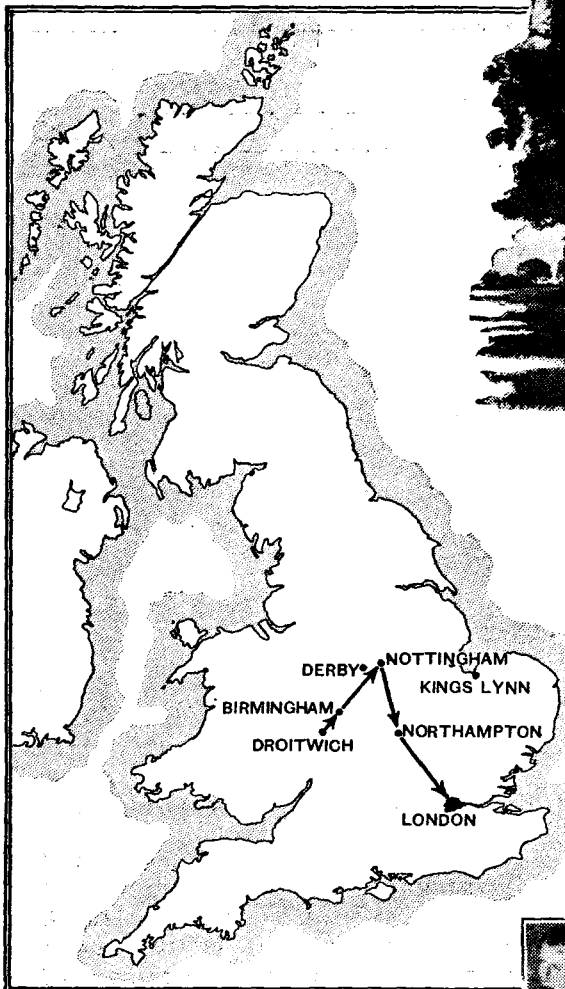

DROITWICH, at the heart of the regions, and the B.B.C.'s last link with millions of listeners.

misgivings about provincial broadcasting, about the "coverage" of transmitters, and about the quality and scope of programmes. Are such suspicions justified?

These questions face me as I set out for Droitwich. The equipment of the expedition is a small car, a large quantity of curiosity, a McMichael portable, myself.

* * * *
The twin masthead lights of Droitwich: our journey's first

amount of data collected," said the engineer who welcomed me. "It was unlucky that such strange reception conditions coincided with the opening of Droitwich."

"Will they recur?" I asked. The engineer shrugged his shoulders, dismissing an unpleasant subject.

Hundreds of experiments have also been made with the Midland Regional aerial in an endeavour to extend the service area to the north-east, Nottingham way. The Regional aerial, a single wire sloping to the masthead, might easily be mistaken for a guy-wire, and it now has a reflector,

similarly sloped. Both reflector and aerial are energised, with a phase difference between the two. The resultant polar diagram of Midland Regional is shaped roughly like a cottage loaf, with its top in Nottinghamshire.

There was an interesting surprise for me in the machine room. One of the two 11,000-volt H.T. generators was switched

off, but nearby a new generator of the same type, packed roughly on blocks of wood, was humming away, its "lash-up" wiring contrasting amusingly with the spick-and-span condition of everything else at Droitwich. This machine is on test prior to being shipped to the new North Irish Regional station at Belfast.

In the engine room only three of the

I.—Through the Midlands

MY first despatch to *The Wireless World* comes from the Midlands, the very heart of those provincial regions through which I am to travel on a journey of investigation, reporting on the steps now being taken by the B.B.C. to improve its services, and enquiring how far those services still fall short of satisfying the legitimate needs of listeners in every part of these islands.

Now is a time of great provincial activity. No fewer than seven new transmitters or studio-centres are either building or planned. Reconstruction of stations and staffs is afoot up and down the country. I am curious to know exactly what is being done—and why.

I will not conceal that I start out with



No station is "friendlier" than Midland, directed by Percy Edgar, who is here seen (second from right) presiding over a meeting of the Programme Board.

beacon. One can just discern, outlined against the starry sky, the National aerial, the B.B.C.'s last link with countless millions from Land's End to John o' Groats. A simple "T" aerial—for despite all the bother last winter about fading on Droitwich, there have been no permanent aerial alterations.

"A great many tests were made, a vast

Britain ?

By **LESLIE BAILY** he has worked in close touch with the B.B.C. in the preparation of feature programmes

Leslie Baily, deviser of the famous "Scrap-book" programmes, has been a radio journalist since 1923. In addition to his newspaper activities

THIS is the first of a novel series of articles in which the author will describe week by week a tour now in progress to discover to what extent the B.B.C. is fulfilling its obligations to the listening public. Are the much-talked-of improvements in transmission proving effective? Are the programmes suited to the needs of the regional populations? Why are B.B.C. staff changes in the various areas of such frequent occurrence? These and many other questions Mr. Baily hopes to answer by visits to each broadcasting station in turn and by personal contact with listeners in all the B.B.C. regions.

750 h.p. Diesels were running: the engineers were "decoking" the fourth. This job is almost continually going on, from one engine to the other. As three engines together are needed to supply power when



Owen Reid, deviser of many Midland programmes, at the dramatic control panel.

the National and Midland transmitters are both on the air the margin of safety seems rather small.

Not much else to report at Droitwich, so we say adieu to Mr. Wheeler and his staff of thirty-five, and within an hour we reach the Broad Street offices in Birmingham.

These premises were recently reconditioned. There are now five up-to-date studios. Nevertheless I found both studios and offices uncomfortably congested. This place is hopelessly inadequate as Midland Regional headquarters. Result: the programme time-table has to be drawn up with undue deference to studio facilities—sometimes programmes are switched to another time, or even cancelled, because of the difficulty of working in transmissions and rehearsals.

Additional premises will be rented this winter, but the adequate solution is to build afresh. That *must* be done eventually, because the Municipality is planning to drive a new street clean through where "the B.B.C." now stands. Further, Sir John Reith has now promised each of

the Regions a brand new Broadcasting House of its own.

That brings me to the most important conclusion of my first journey. The provinces in future are going to get a better deal from London headquarters . . . more men and money, less interference and restriction. "Centralisation" is dead. This must be a happy day for Percy Edgar, Midland Regional Director, who led the long and stubborn fight for provincial rights.

Percy Edgar is unique; he has been director here since the B.B.C. began. His is a rare personality of leader-

ship, combining authority with humanity. No station is "friendlier" to its listeners than Midland. But friendliness, and the reflection in its programmes of the talent and life of the Region, are not enough; provincial programmes should stand comparison *in quality* with those of London. "Provincial" should not be synonymous with "second-rate." That is the next step in Mr. Edgar's policy—to spend the additional revenue not in increasing the quantity of Midland programmes, but the quality.

"What we do, to do it superbly well" is Percy Edgar's new motto, as he expressed it to me. In practice it means, chiefly, more rehearsals. (And that will further embarrass the studio situation!)

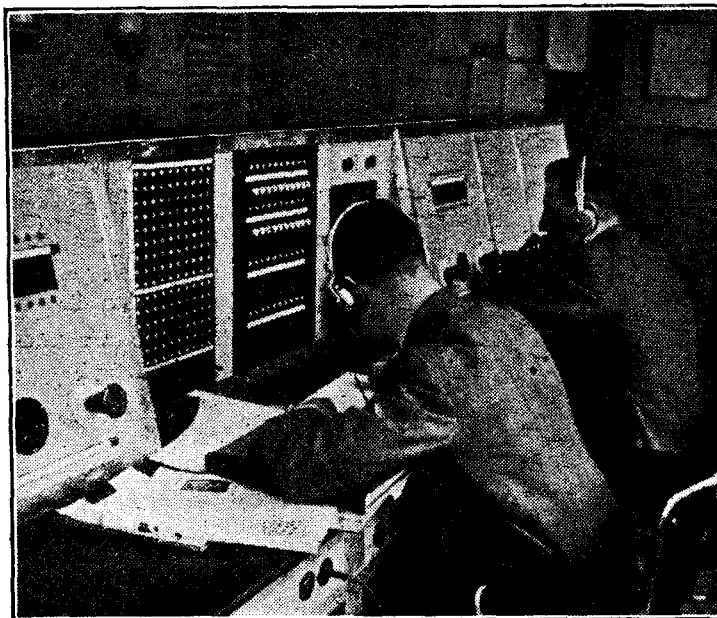

Birmingham studios have a staff of 78, including 21 engineers, two of whom are here seen in the control room.



The Midland Orchestra, now re-formed after an unpopular period of disbandment. It is conducted by H. Foster Clark.

Does Broadcasting Serve Britain?

This new generosity of London towards the provinces means not only more cash for programmes, but for staff and equipment. The Midland and West Regions are to share a brand new recording van (Scotland and North will share another). I noticed that Reiss and moving-coil microphones are still used at Birmingham, but the new ribbon microphones as used in London are soon to be substituted.

For months Mr. Edgar has been reconstructing and expanding his staff, now complete except for one—a "topicality man," who will be charged with the unprecedented job of bringing last-minute items of all kinds into the programmes.

As one who once did a good deal of broadcasting in the provinces, I know very well the evil effects of understaffing, so I rejoiced to find that Birmingham's studios are now well manned. Many of the new men are very young, but there is a backbone

of old stagers: Edgar himself and Harold Casey, his chief administrative official, who has been with him since the earliest days; H. J. Dunkerley (Programme Director), Martyn Webster (Variety Director), and J. E. Cowper (Chief Announcer).

The staff totals seventy-eight, including twenty-one engineers, plus orchestra of thirty-five. The orchestra has abundantly justified itself in the year which has passed since Percy Edgar persuaded London to return unto the Midlands that which was the Midland's: their full-size Orchestra, the disbandment of which was the greatest crime in the whole clumsy history of centralisation.

But let us not recriminate. Let us, in fact, acknowledge that Roger Eckersley, one-time advocate of centralisation, has done the Big Thing. Having lately spent long periods in the provinces he has seen into the heart of things, and is now giving the Regional Directors warm encouragement. The whole "angle" of London on this thing has shifted. It is now recognised that if Sir John Reith's Regional policy is worth carrying on at all it is worth whole-hearted support.

So far, so good. Yet we are a long way from an even mildly satisfactory translation of that policy into practice. This also have I learned on this journey.

I motored on to Nottingham. As I went I noticed the signal strength of Midland Regional dropping rapidly.

Nottingham is nearly seventy miles

from the Midland transmitter at Droitwich. At one time this city of 270,000 inhabitants had a relay station of its own, which also served the surrounding towns of Derby, Grantham, Loughborough, Mansfield and Newark.

Local programmes, from the Nottingham studio, appealed to listeners' local pride. To-day local artists must travel to Birmingham to broadcast. I heard of Nottingham bands which have declined

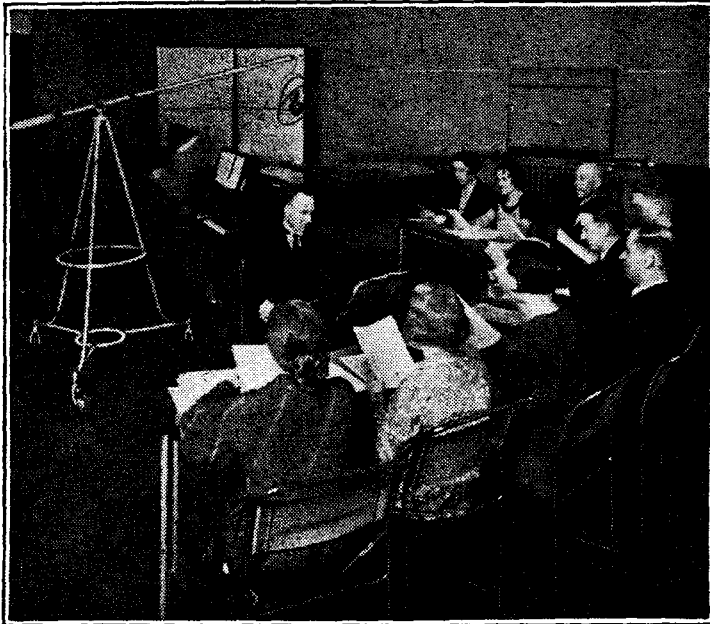

The Midland Wireless Singers are great favourites with a host of listeners. Their conductor is Edgar Morgan.

engagements because (a) travelling expenses subtract heavily from the fee, (b) in the case of a works band they cannot get time off to travel to and fro. Anyhow, most people listen to North Regional because reception is so much better.

"Yet the people in this area have more in common with the Midlands than the North," said Mr. F. Sharp, of the Nottingham Guardian, leading champion of Nottingham's case, whom I met. He added: "We feel that we have been let down by the B.B.C."

The B.B.C. has so far admitted the inadequacy of Midland's radiation in this north-easterly direction that the whole of Lincolnshire (hitherto exploited by Mr. Edgar) has been transferred to North Regional administration. Geographically and artistically, it would be absurd to add North Nottinghamshire to the North, yet something must be done to straighten out this ludicrous situation. Here is the first of the "neglected areas."

To start with, there must be a Nottingham studio, connected up to the Midland Regional transmitter. Sharp and Co. have a cast-iron case. They meet both sympathy and opposition from the B.B.C., but if they keep on agitating I believe they will get studio and staff. What use, however, will that be while reception is unsatisfactory? This must first be improved by modification at Droitwich (can Midland be given a longer wavelength than 296 metres?), or by the re-establishment of a relay transmitter at Nottingham. The

latter course is urged by the Rev. Walter Pitchford, who lives in a village near Northampton. Mr. Pitchford is not only a prominent broadcaster in the Midlands, he knows intimately the people of this countryside.

"I get complaints," he told me, "from a wide area, reaching across right to King's Lynn. That eastern country seems to be completely neglected by the B.B.C. so far as a Regional alternative programme is concerned. It is futile to talk about population and licences; there are more listeners in the towns, but listeners in the country value and appreciate the wireless more."

So at present Droitwich National booms in everywhere, but the Midland Regional alternative is indifferently received over a part of the Midland area. The removal of this transmitter from Daventry to Droitwich, to the bottom left-hand corner of its Region, and the shortening of its wavelength, has proved a blunder.

One can only hope that it will be rectified speedily, in order to give 100 per cent. Midland distribution to those better-quality programmes that I found Percy Edgar and his staff so enthusiastically planning at Birmingham.

Next Tour: *Along the South Coast.*

At the Transmitting End

Technical perfection has not yet been attained at the transmitting end. To assist readers in assessing the performance of their receivers in respect of particular programmes we propose inserting from time to time brief criticisms of certain transmissions.

Balance

STUDIO transmissions are invariably very good, particularly with such regular performers as Henry Hall and his band, yet, even here, the general balance can sometimes be criticised.

During the "Band Box" show (National, October 15th) this orchestra played one tune in particular, "Cheek to Cheek," in which the bass was weak. This may have been due to microphone placing, or merely that the double-bass player was not working with his customary abandon. One wonders whether Henry Hall should occupy a glass-panelled, sound-proof cabin equipped with loud speakers, and direct his band accordingly.

Modulation Depth

DEEP modulation may be necessary and even desirable during the News Bulletin, but it is really distressing when used for the general announcements between musical items.

The transmission of Reginald King and his orchestra in the Regional programme on Tuesday evening of last week was technically excellent but for this one serious failing.

The correction of this error calls for some degree of artistic control on the monitoring side, but it is an effort that is well worth while, and should at least be attempted.

H. C. H.

Current Topics

EVENTS OF THE WEEK
IN

BRIEF REVIEW

Hark, the Herald . . .

SWEDISH listeners call the announcer "Hallomann." For some strange reason Norway hates to use the same word, so a large group of listeners is coining a new term, "Herold" (herald).

7½ Million

NEARLY 7½ million British wireless licences were in force at the end of September, the actual total being 7,224,123, compared with 6,473,990 a twelvemonth previously. Approximately 478,608 licences were issued during September.

Jerusalem v. Manchester

OUR grandfathers would have rubbed their eyes at this headline in a Manchester paper last week: "Jerusalem's Threat to North Region." The reference was, of course, to the possibility that the new Palestine station on a wavelength of 449.1 metres might heterodyne the Slaithwaite transmitter. Jerusalem will have a power of 20 kilowatts.

Restrictions in Egypt

AFTER some years of comparative freedom, amateur transmitters in Egypt are finding rather irksome the new restrictions just placed upon them by the Egyptian Government. Operation is permitted only in a few limited and inconvenient channels. The licence fee is £2 a year, and 1s. is levied on each valve used.

The great majority of Egyptian amateurs are British members of the Army and R.A.F. stations there.

Australia's Wave Change

AT midnight on August 31st, thirty-six of the eighty-eight national and licensed broadcasting stations of Australia operated on revised wavelengths. The change passed over without mishap. In general, a minimum of 10 kilocycles separates the stations under the redistribution, and a tolerance of 50 cycles is allowed in operation. Many of the stations have recently been equipped by Amalgamated Wireless or Standard Telephones with crystal control, and the former company reports that the stations fitted maintain their frequency within 10 cycles. Both the Postal Department and Amalgamated Wireless have installed highly accurate fre-

quency measuring equipment, with which the stations' performances were checked with general satisfaction.

DX Ban in Rome

ACCORDING to the *Daily Telegraph*, keepers of hotels and bars in Rome equipped with wireless sets have received official orders not to tune in foreign stations.

Broadcasters on the Dole

THE "amateur hours" in American broadcasting, in which aspirants for microphone honours are given auditions on the ether during the less valuable periods, are producing an unemployment problem. The flood of ambitious young talent in New York City has reached such a high peak (writes a correspondent) that radio staffs have joined with relief officials in warning amateurs against coming to the metropolis. At the present time about three hundred prospective radio amateurs are being given transient relief weekly.

New Zealand's Claim

ACCORDING to Mr. G. G. Samson, a leading New Zealand radio authority, his country possesses more amateur transmitters per head of population than any other. There are five amateurs per 10,000 population in New Zealand, he says, compared with two for the U.S.A., 1.5 for Australia, and 0.3 for the British Isles.

Because a low "amateur population" means a low interference level, British amateurs have something to be thankful for!

H.M.V. Radiogram at Science Museum

VISITORS to the Science Museum will now be able to see one of the "His Master's Voice" fifteen-valve High Fidelity Autoradiograms, which has just been installed there as representing the latest development of radio and gramophone research. It forms part of a collection of more than thirty different instruments showing

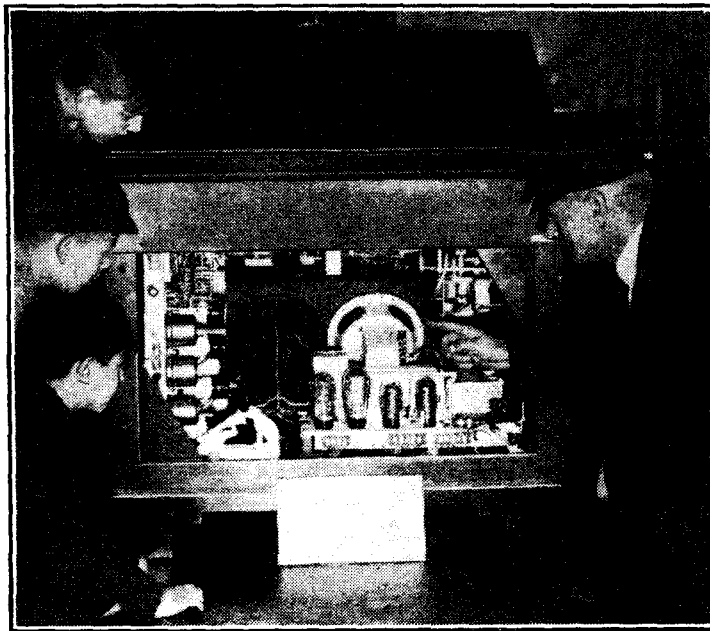

MILESTONES IN RADIO. An H.M.V. high-fidelity radiogram has been added to the collection of wireless apparatus at the Science Museum representing the many stages in the development of radio during the last quarter-century. The interior is specially illuminated.

Transatlantic Baseball

W₂XAF, Schenectady, recently issued this announcement: "W₂XAD and W₂XAF will be on the air every Saturday afternoon during October and November relaying running commentaries on baseball and football matches, commencing 1 p.m. (E.S.T.) (6 p.m. G.M.T.).

the progress in these industries for the past quarter of a century.

The interior of this H.M.V. radiogram is specially illuminated, and thus visitors are able to get some idea of the complex construction of this instrument, which incorporates 6,381 parts, some of which are even gold-plated.

A Record Break

THE installation of the new broadcast network of lines in Norway for outside broadcasting has considerably improved the service, but has brought its own train of troubles. The engineer in charge of the Vadso station in the Far North was recently waiting for the Sunday morning service broadcast from Oslo. Getting no response from headquarters he and his staff set off on skis for the local village church, fixing up lines there to ensure that listeners should have their morning service.

Subsequently it was found that the line to Oslo had been broken in forty places *en route*.

At the Exide Luncheon

OVER 250 people were present at the Exide Annual Motor Show Luncheon at the Clarendon Restaurant, Hammersmith, on October 17th.

One of the principal guests was Mr. Frank Murphy, who spoke on the subject of car radio. He emphasised that his remarks were those of an individual and not representative of the radio industry.

There were many drawbacks, he felt, in having radio fitted permanently to a car. It added to the cost by some £20, which might be more profitably spent in more essential improvements or fittings.

He did not think that car radio would achieve a vast popularity in this country.

Blind-landing

HESTON is to be the first British airport to be equipped with the Lorenz blind-landing system. The successful development of this system in Germany, coupled with the obvious need of a standardised type of approach beacon for use at all international aerodromes, is leading to the rapid adoption of this system for Europe. Installations are either planned or already completed in at least ten European countries, while over fifty passenger aeroplanes of the Lufthansa Company have been equipped with the necessary receiving apparatus. The Heston apparatus is to be installed immediately by Standard Telephones and Cables, Ltd. (who own the British rights) in accordance with plans prepared by Mr. Roderick Denman, Technical Director of Airwork, Ltd.

The Radio Companion

By J. H. REYNER, B.Sc. A.M.I.E.E.

IN this article the author describes the construction of a really pocket portable. Originally built for his own requirements, it proved so efficient that we felt many readers would be glad to have details of it.



A WEEK or two ago I went round to play Bridge with some friends. At the last moment my wife said: "Put that little gadget in your pocket. They might be interested to see it."

The little gadget referred to was a pocket radio set which I had just completed after some weeks of experiment. I was feeling rather pleased with it, but I was quite unprepared for the reception it obtained.

My friends were positively enthusiastic. Though they had had an all-mains set in the house for many years they hailed this as real radio. So much so, that the business of the evening was held up for a considerable time while we discussed the possibilities.

The appeal of a little pocket set of this type is extraordinarily wide. There is the fact that it is *really* portable, so that it can be carried about without effort. It provides information for the person who is using it and nobody else, which is often a convenience. It can be taken in a car or on any sort of journey—in fact, the man who has any travelling to do will find it a useful accessory which tucks away in a corner of his suitcase. Again, the hiker or cyclist can accommodate such a set about his person with the minimum of inconvenience, and, finally, it makes a most attractive present which can be given or sent to anyone, and is instantly ready for use without any extra preparation at all.

The cause of all this excitement is described herewith. It is a three-valve set measuring 7½ in. by 4½ in. by 1½ in. complete with batteries, so that it is truly a pocket receiver. It houses a self-contained frame aerial and is capable of giving satisfactory reception from any B.B.C. station at a radius of fifty miles. The actual model described receives both the Londons and will also tune in Midland Regional somewhat faintly but distinctly and intelligibly in daylight at Elstree. After dark quite a number of Foreigners can be received, but the set must be regarded as a local station performer with a normal range of a safe fifty miles.

The circuit used is a "straight" one, and is shown in Fig. 1. Some little time was spent in experimenting with super-regeneration, but the early results gave the impression that this form of circuit was rather like the little girl with the curl—when she was good she was very very good, but when she was bad she was horrid. On the other hand, if suitable precautions were taken, a three-valve straight set can be made to give quite remarkable results and to give them every time. The circuit used in this set has been built up in two or three different forms, and on each occasion it has functioned straight away without hesitation, so that one can feel reasonably confident of the result.

The valves used are Hivac midget types. An XD is used for the detector,

transformers, and the extra cost is very small. Bulgin midget transformers, Type LF33, are used, and they fit comfortably into the space available, occupying little more room than would be required for the necessary components of a resistance-coupled stage.

The use of two transformer-coupled stages is apt to be tricky, but with the layout adopted in this receiver no trouble is experienced. A small amount of inverse reaction is provided by reversing one of the primaries, and the arrangement is quite stable even when the high tension battery voltage has fallen as low as 20, by which time it has become unusable, as the reaction is not sufficient.

For tuning, "Preset" condensers of 0.0005 capacity have been used for two reasons. In the first place they are

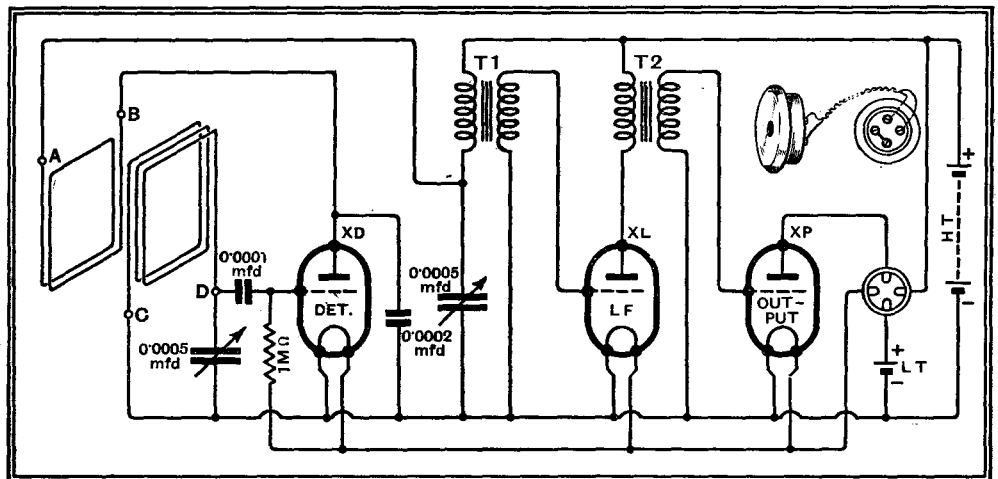

Fig. 1.—The circuit diagram—detector and two low-frequency stages.

an XL for the first LF stage, and an XP for the output stage. A 33-volt HT battery is used, this being one of the Drydex midget X81 batteries specially designed for this class of work. Under these conditions it is found possible to dispense with grid bias owing to the low HT voltage and the small grid swing involved. This sounds horribly unscientific in these enlightened days, but the valves are, in fact, designed to be suitable for this condition of operation.

The valves are transformer coupled. In the earlier experiments resistance coupling was tried for one of the stages, but it was found that a definite improvement in performance could be obtained by using two

smaller even than bakelite-paper condensers, for as a general rule the latter type of condenser, though flat at the back of the panel, projects a considerable distance in front. Secondly, their losses are considerably less than the bakelite paper type, and although one can make up loss by reaction it is always preferable, when dealing with a very small signal, such as is obtained with a small frame, to start off with as little loss as possible. The disadvantage of the preset condenser is that its range is restricted, but since the receiver is essentially for local station reception this is of minor importance. Alternative specifications have been given for the frame according to the wavelength

A MIDGET RECEIVER OF UNUSUAL PERFORMANCE

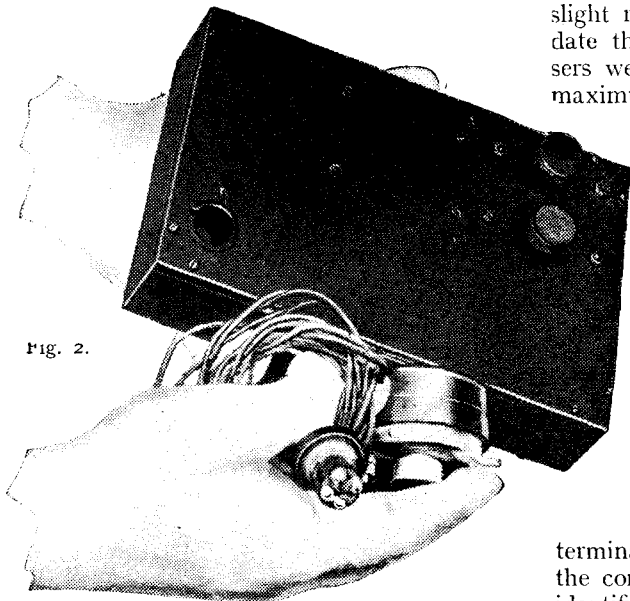

Fig. 2.

range most suitable for the particular user.

The output from the receiver is supplied to a telephone earpiece which is separate from the set. This has been done for various reasons. In the first place the inclusion of a space in the receiver for the purpose would have meant a material increase in the size of the set, not only in length and breadth, but also in depth. Secondly, it would have tied down the design to one particular type of telephone, whereas many readers will already have a suitable earpiece available. Any good 1,000 ohm earpiece may be used, *i.e.*, one half of the standard 2,000 ohm high resistance pair of telephones. In the original model I used a Brown phone which I happened to have, and the improved sensitivity of this type did, of course, help on the long-distance results, but a very satisfactory performance has been obtained with a less expensive type of instrument.

How Components are Housed

Let us now consider the detailed construction of the set. The receiver proper is housed in one corner of an ebonite panel which covers the whole front of the set. The three valves are mounted on a small strip a little way clear of the panel. This composite strip with the valve holders can be obtained from Messrs. Lectro Linx. It should be held off the panel by small metal brackets at the extreme ends. Metal elsewhere along the strip should be avoided as it may tend to introduce coupling between valves.

Between the valves and the panel, above the strip, are mounted the tuning condensers. Polar compression type condensers are used for this purpose, with

slight modification in order to accommodate them in the space. Both condensers were of 0.0005 microfarads capacity maximum.

The fitting of these condensers is as follows. First of all the two lugs at the extreme ends of the condenser are cut or filed off, being careful not to break the bakelite, which is inclined to be brittle. Then the compression screw is removed completely and also the terminals and the nuts underneath them. The case of the condenser can now be removed. Note which of the two terminals is connected to the top plate, *i.e.*, the plate on which the compression screw operates. Mark this particular terminal with a scratch on the bottom of the condenser assembly, so that it can be identified again when wiring up.

Constructional Details

Now drill the holes in the panel for fitting the condenser. There are two holes at the outside to take the terminal shanks and a hole in the middle to accommodate the bush in which the compression screw is located. The outside holes are straightforward holes drilled according to the dimensions given on the diagram. The centre hole has to be countersunk from

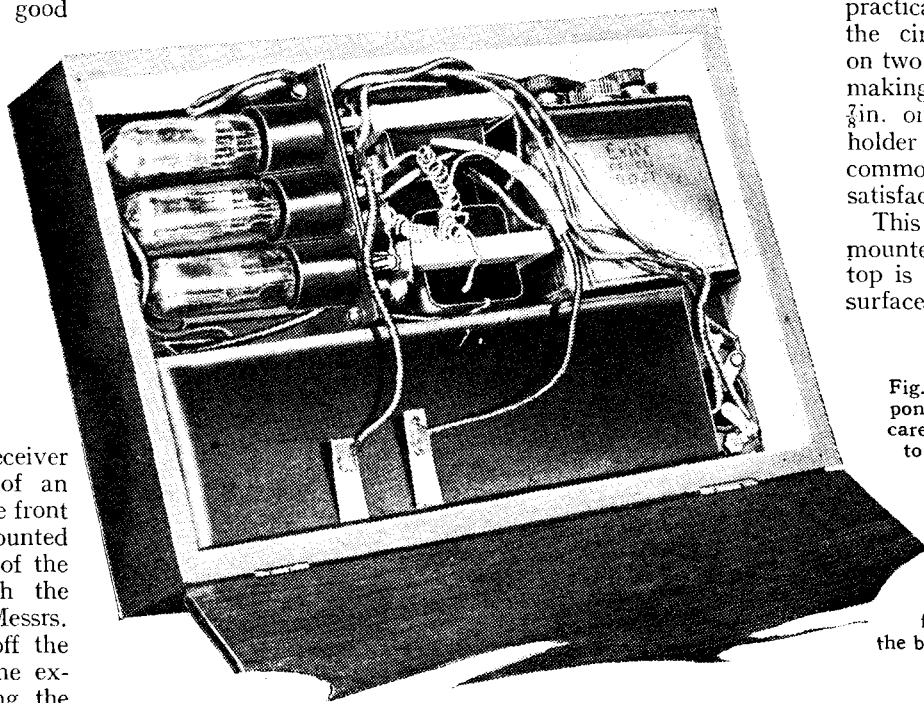

Fig. 3.—The component parts are carefully arranged to make use of all available space, the valves, accumulator and HT battery being the prominent features when the back is removed.

the underside of the panel. It is first drilled through with a $\frac{5}{16}$ in. drill and then countersunk from the underside until the case of the condenser fits tightly up against the back of the panel.

Now replace the cases on top of the condensers and push them through from the back of the panel with the moving (marked) plates at the bottom, *i.e.*, next to the valve holder strip in each case. This is important, to avoid hand-capacity effects. The condensers will fit snugly up against the panel and the nuts may be screwed on to the terminal shanks, which now project through the panel. The extra length of shank, when the nut has been screwed home, may be cut off and filed flush, and the condenser is now ready to operate. If the operating screw is inserted into the centre hole and screwed up the condenser will behave in normal manner. The operating screw actually supplied with the condenser has a very small knob, and I found it preferable to use some rather larger knobs which I happened to have by me. The compression screw has a 5B.A. thread, so that the knob used must be tapped accordingly.

The mounting of the two transformers is quite straightforward, and the remaining components on the panel are the grid condenser which is accommodated between the tuning condensers, and the 0.0002 by-pass condenser and 1 megohm grid leak, which are housed under the valve-holder strip.

Now, in the corner of the panel drill a $\frac{3}{8}$ in. diameter hole, as shown to the left in Fig. 2. This is to accommodate a small bayonet-type valve holder which is used as the phone connection and on-off switch at the same time. This is the standard "Weco" valve socket, as used for the earlier type of Hivac valve. The valve holder itself will have to be filed with flats on each side, as otherwise the flange occupies too much room. If the flange is cut away practically flush with the circular portion on two opposite sides making the width $\frac{3}{8}$ in. only, the valve holder can be accommodated quite satisfactorily.

This must now be mounted so that the top is flush with the surface of the panel,

and for this purpose two one-inch 6B.A. screws are employed. The screws are inserted in the panel first of all, being countersunk so that their heads come flush with the panel, and are held in position by nuts on the other side. Then either a

The Radio Companion—

short collar is placed over each screw, or a second nut is run down and is adjusted until its outer edge is just $\frac{3}{8}$ in. from the panel. The valve holder is now dropped over the two screws and two further nuts

A special plug will be required for this socket. This is made up as shown in Fig. 5. Four round-head screws spaced evenly round a $\frac{3}{8}$ in. diameter serve as contact pins, while a locating pin is fixed midway between two of the contact pins. A No. 4

The two contacts on the far side from the locating pin are strapped together with a piece of thin (30 s.w.g.) wire, while the remaining two contacts are used for the 'phone leads, which are pushed up through the centre hole. The plug thus serves the

FULL CONSTRUCTIONAL DETAILS

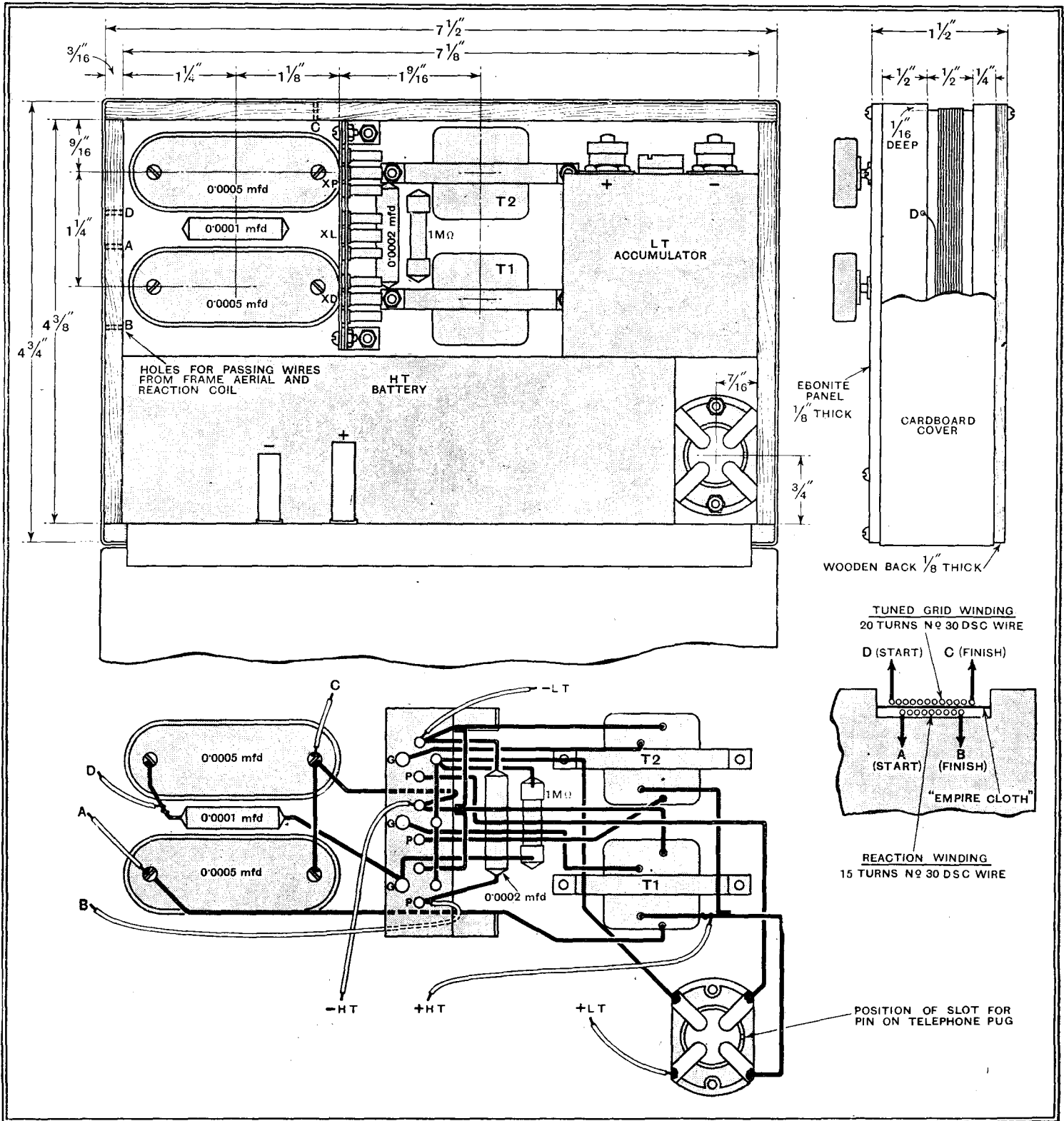

Fig. 4.—Dimensions, layout of components, wiring connections, and details of frame aerial assembly.

run down to lock it in place. It will then be found that the top of the valve holder is flush with the surface of the panel.

Make sure that the socket is mounted so that the slot is facing the edge of the panel, as shown on the assembly diagram.

wood screw with the head filed off is convenient for this pin, while the contact pins may also be No. 4 wood screws. If a rather smaller hole is drilled the screws are self-tapping, and will bite into the ebonite quite satisfactorily.

double purpose of a switch and 'phone jack.

The wiring can now be commenced following the details given in Fig. 4 and it is convenient to remove the valve-holder strip at this stage, so that the fila-

The Radio Companion—

ment wiring can be run. From one side of the filament busbars leads are taken to the LT- and HT-. From the positive busbar a lead runs to the valve holder in the bottom right-hand corner, from which another lead runs to LT+. The remaining two connections on this valve holder go to the anode of the output valve and HT+. The valve strip may now be reassembled and the rest of the wiring completed, this being a matter which is accomplished without difficulty. Remember to get the transformer connections correct, as specified on the diagram, and to make sure that the grid leak, which is housed between the two transformers, does not touch any HT connection.

The connection of the frame to the tuning and reaction condensers is discussed later, but it may be mentioned here that the connections are soldered to the appropriate terminal screws on the bottom of the preset condensers. These screws are plated, and it is advisable to scrape them slightly with a knife before soldering to ensure a good joint.

We now turn attention to the frame, which is built into the woodwork of the case. A simple plywood case is sufficient, three-ply wood $\frac{3}{16}$ in. thick being used. A groove $\frac{1}{2}$ in. wide is cut in the outside by making saw cuts $\frac{1}{2}$ in. apart and removing one layer of ply. This is to accommodate the frame. It is important that the frame should be wound on with the reaction winding first. This consists of eleven turns of 30 d.s.c., slightly spaced to accommodate it comfortably within the $\frac{1}{2}$ in. A layer of Empire tape is then wound over the reaction winding and the tuned winding is wound on, this consisting of fourteen turns of 30 d.s.c., again slightly spaced. The start and finish of the windings is clearly indicated on the connection diagram, it being important, of course, to ensure that the tuned winding and the reaction winding are in the correct relationship to obtain reaction. The ends of the frame are brought through the inside ready for connection to the tuning condensers, and a short length of spare lead should be left so that there is no difficulty in connecting up.

Frame Connections

The ends of the frame are now connected to the various points on the panel. The tuned winding is connected between the grid condenser and LT-, and the reaction winding between the anode of the detector valve and the primary of the first transformer, which point is also connected to the reaction condenser which bypasses transformer primary. These leads must be sufficiently long and flexible to allow the panel to be opened out like the flap of a book for insertion or removal of the valves.

This completes the wiring, and the valves may be inserted in their pockets and the panel fitted over the frame and screwed home with four screws in each corner. To complete the receiver it is now necessary to make the back, which can be

of plywood or bakelised linen, as desired, and to cover the sides of the frame with some suitable material. This may be thin card, thin plywood or black empire cloth or book-binding cloth. The back may be hinged in position if desired, either by using small hinges for the purpose or by using a piece of adhesive (medical) tape, which makes quite a convenient hinge.

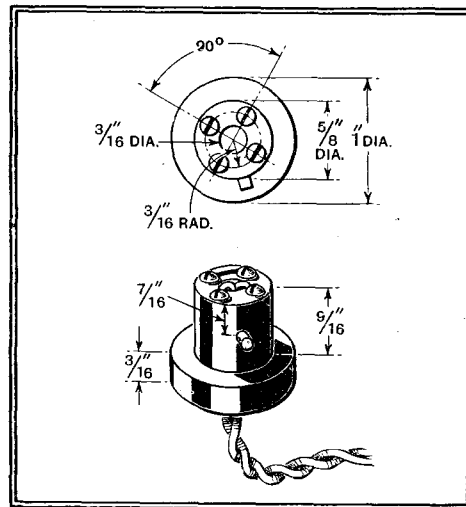

Fig. 5.—The plug and socket arrangements for making connection with the telephone earpiece.

The batteries may now be inserted. The accumulator, which is an Exide Gel-Cel RDJ1, is fitted into the space immediately below the transformers, while the HT battery is accommodated down the side. This battery is made with spring connectors, and the reader who feels so inclined could wire up the HT points to two screws on the underside of the panel, so positioned that they would locate with the spring clips. In my own case I merely soldered the ends of the wires direct on to the connection springs, first bending these down the side of the battery, so that when it is in position they appear on top, as shown in the drawing.

Ease of Control

The operation of the receiver is straightforward. It will be found that the reaction is particularly smooth, which enables one to use very critical control when necessary. For ordinary purposes, however, a small amount of reaction is quite sufficient to bring in the stations at satisfactory strength. Owing to the fact that the reaction winding has to be fairly large relative to the tuned winding, a certain amount of pulling between the two controls is inevitable. This large reaction winding is necessary to compensate for the losses introduced by the batteries immediately inside the frame. The process of tuning, therefore, is to adjust the reaction condenser so that the set just oscillates with a faint hissing sound. Then rotate the tuning control until the whistle of the station is heard. The reaction should then be reduced a little when the whistle will change in pitch and probably vanish altogether. Readjust the tuning control until it comes back. Then reduce the reaction setting a little more and again re-

tune. Continue in this way until the circuit is not oscillating and you will find a strong, clear signal.

The direction in which the receiver is pointing makes some difference owing to the directional properties of the frame, and for the same reason the receiver should be used in an upright position, at any rate when tuning in. It is possible, particularly fairly close to a local station, say, ten or twelve miles away, to receive satisfactorily with the set lying on its back, but when searching it is preferable to stand it on its side or on its end and occasionally to turn it round to make sure that it is not actually located in a dead position, *i.e.*, at right angles to the direction of the incoming wireless wave.

For Higher Wave Range

The range of the receiver as described is from roughly 250 to 400 metres. Those readers who wish to achieve a somewhat higher wave range than this should use an alternative frame winding, comprising fifteen turns reaction and twenty turns tuned winding, the reaction being wound on first as before. This will give a range of roughly 350 to 550 metres, and one or other of these two ranges should cover any local station requirements.

The filament battery supplied is, of course, very small, but each charge will actually last for some ten hours, but then the receiver is usually only used for ten or fifteen minutes at a time. The HT battery consumption is of the order of $1\frac{1}{2}$ to 2 milliamps., under which condition the battery will have a life of several months.

The principal components required:—Three midget **Hivac** valves, types XD, XL and XP; a 33-volt **Drydex** HT battery, type X81; two **Bulgin** midget transformers LF33; a 3-valve holder unit by **Lectro Linx**, whilst two **Polar** preset condensers are used for tuning and reaction respectively. The LF accumulator is the **Exide** Gel-Cel No. RDJ1.

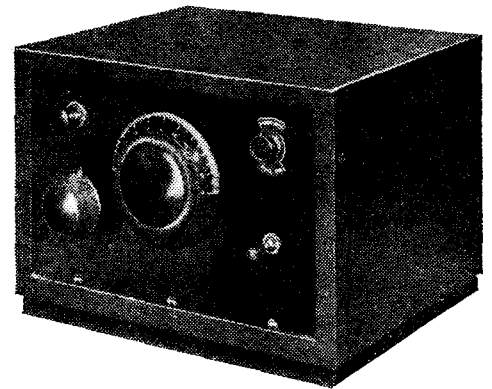
CRYSTAL REVIVAL

The National Radio Service Company's crystal set, designed by Mr. R. W. Hallows to cope with modern conditions. A wave-trap for eliminating local-station interference is included.

The Small Superheterodyne

DESIGNING INEXPENSIVE EQUIPMENT

A superheterodyne employing a limited number of valves is now capable of a performance which comes as something of a revelation to those who are accustomed to the results given by older sets of similar types. Careful design is needed to secure the best results, and in this article the chief factors which govern the choice of circuit are discussed.

THE day is long past when a superheterodyne necessarily included eight or more valves, and thanks largely to modern valve development it is now possible to build a set having a very high standard of performance which employs no more than three receiving valves. It is true that one or more of these may be double valves, but in popular parlance they count only as single specimens.

A superheterodyne for loud speaker operation must include a frequency-changer, an IF amplifier, a detector, and an output valve. This is the bare minimum, and in days gone by would have necessitated five valves at least, since two were needed for the frequency-changer. To-day, three valves only are needed, for one of the combination diode types can well serve as a combined detector and output valve. Thus all the functions essential to the superheterodyne can be performed by three valves, but this alone does not mean that the receiver will be satisfactory. It is far more important that the set should be sensitive, have adequate selectivity, and give good quality reproduction than that it should be of any particular type which happens at the moment to be fashionable. These characteristics are, however, most easily and cheaply obtained with the super-

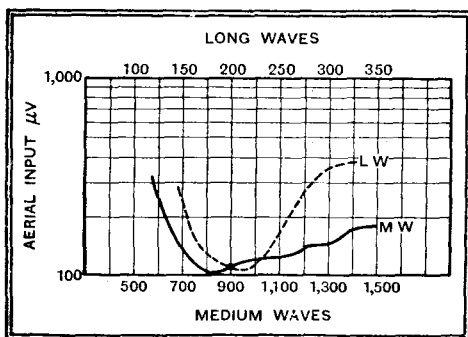

Fig. 1.—These curves show the high sensitivity obtained with a three-valve superheterodyne. They are for an output of 50 milliwatts at 30 per cent. modulation.

heterodyne, but careful design is essential if a good performance is to be secured with such a limited number of valves.

A diode detector is essential if distortionless rectification with a satisfactory AVC system is to be obtained at low cost, and the output stage must be fed directly from the detector, for an IF stage is needed, and there is then no valve to spare for an

intermediate LF stage. Transformer coupling immediately following a diode is ruled out by considerations of quality of reproduction, so that the output valve must be fed from the detector through a resistance-capacity coupling. There is then no alternative to a high-efficiency pentode for the output valve, for such a valve requires only about one-tenth the input of a triode for the same output. As such valves are available fitted with two diodes, the valve for the detector, AVC, and output stages is naturally a duo-diode-output pentode.

For the IF stage, an HF pentode of high mutual conductance is an obvious choice, and for the frequency-changer one of the special valves developed for this purpose. The precise type of valve used must be selected on its performance, and for a set of this nature the triode-hexode has certain advantages over other types. It has, for instance, an unusually high AC resistance for its conversion conductance, and this is of importance in securing high selectivity.

The Intermediate Frequency

Having tentatively selected the valves and decided upon the functions which they must perform, one very important question must be answered before the design can proceed any farther. What intermediate frequency shall be used, 110 kc/s or 465 kc/s? The low frequency will permit both higher amplification and selectivity to be obtained, but two signal-frequency tuned circuits will be essential if second-channel interference is to be kept at a reasonably low level. With a frequency of 465 kc/s, however, it is not difficult to obtain variable selectivity, and the reproduction is likely to be better than with the lower frequency; moreover, a single signal-frequency circuit will suffice for second-channel rejection if correctly designed. The higher intermediate frequency is thus likely to prove somewhat cheaper than the low as well as having certain technical advantages. It is, consequently, the one to choose, provided that experiment shows the amplification and selectivity to be adequate, even although they may not be as high as at the lower frequency. It may be said at once that experiment does show it to be readily possible to obtain adequate amplification and selectivity at 465 kc/s.

By W. T. COCKING

Two IF transformers are required for the IF couplings, and that coupling the IF valve to the detector must have coils of high dynamic resistance if good IF amplification is to be secured. The coils in this circuit, however, are inevitably

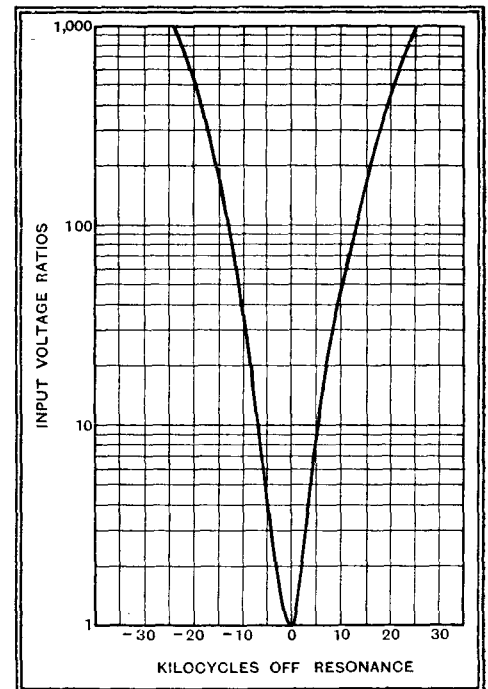

Fig. 2.—This curve shows the selectivity at 1,000 kc/s (300 metres) with the selectivity control set for maximum sensitivity.

damped by the detector and AVC system, so that at this point selectivity can receive less consideration than amplification, and the coils in the IF transformer should be of high inductance and high dynamic resistance, but not necessarily of high Q . To secure the full amplification the coupling between the two coils comprising the transformer must be optimum when the coils are damped by the external circuits. This means that the coupling must be somewhat greater than the optimum for the transformer alone.

In the case of the transformer coupling the frequency-changer to the IF valve, the dynamic resistance of the coils is again of importance as affecting the amplification. Since this circuit is quite lightly damped, however, it is more beneficial to concentrate upon selectivity than upon amplification. It is thus of primary importance that the coils should be of high Q ($=\omega L/R$), and this is most readily achieved with a moderate value of inductance leading to a moderate dynamic resistance. In order to obtain variable selectivity the coupling between the coils in this transformer can be adjustable.

The Small Superheterodyne—

The signal frequency tuning system can now receive attention. Owing to the use of an intermediate frequency of 465 kc/s, second channel interference on the medium waveband occurs almost entirely from stations on lower wavelengths than those devoted to broadcasting. As such transmissions are usually weaker than broadcasting stations less preselection is needed than if a low intermediate frequency were used, and, moreover, the protection against interference afforded by each tuned circuit used is much greater than would be the case with a low frequency. On the long waveband, however, stations which can cause interference are in the medium wave broadcast band. Owing to their greater strength a higher degree of preselection is needed on the long waveband than on the medium, and it is fortunate that this is obtained almost automatically, for the selectivity of long-wave circuits is inherently greater than that of low, the Q of the coils being in each case the same.

Experience shows that when the pre-selector contains only a single tuned circuit the protection against second channel interference is barely adequate for average needs when conventional methods of aerial coupling are used. Moreover, with such a coupling the efficiency of the pre-selector varies considerably over the waveband, while the aerial affects the tuned circuit to such a degree that ganging is difficult unless stray capacities are kept

the two channels of overlap, this second-channel band is distinct from the receiving band. Similarly, for the long waveband of 150-300 kc/s, the second-channel

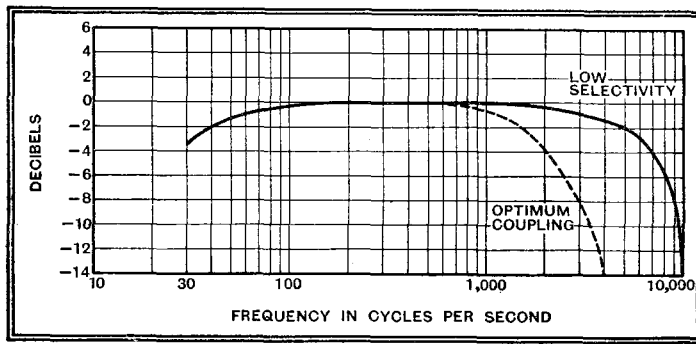

Fig. 3.—The fidelity at two different settings of the selectivity control is shown here and will be seen to be exceptionally good.

band is 1,080-1,230 kc/s, which is very different from the receiving band. Since the receiving and second-channel bands are distinct it is possible to employ a fixed filter system to increase the preselection rather on the lines adopted in single-span receivers. In this way it is possible to obtain any desired degree of second-channel rejection while retaining only one variably-tuned signal-frequency circuit.

The Pre-Selector

In practice, however, it is found that a very simple arrangement increases the preselection to an entirely adequate figure, and it has the further advantage of relieving the tuned circuit of much of the loading effect of the aerial, and of permitting the use of a method of aerial coupling which leads to unusually constant sensitivity through the tuning range. In addition, an increase in efficiency, as

aerial a loading coil of such value that the aerial circuit as a whole is resonant at the middle of the receiving band and of coupling the aerial circuit to the tuned circuit by a combination of two forms of capacity coupling.

The use of this aerial coupling system has been found to lead to a big improvement in performance, and a three-valve superheterodyne designed in accordance with the principles which have been briefly discussed in this article can give an astonishingly good performance. The sensitivity is shown by the curves of Fig. 1, in which the dotted line represents the performance on the long waveband. The curves show the aerial input needed to obtain the standard output of 50 milliwatts at 400 c/s with 30 per cent. modulation. Over the greater portion of the medium waveband the sensitivity is better than 150 microvolts, and at 950 kc/s it is nearly 100 μ V. At its worst point it is 330 μ V. On the long waveband the point of maximum sensitivity is the same as on the medium waveband, and the variations over the band are very little

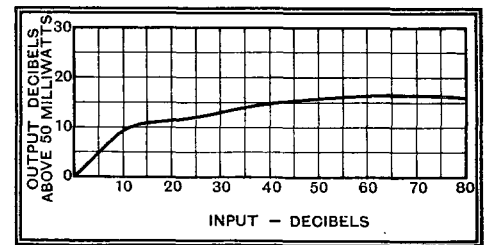
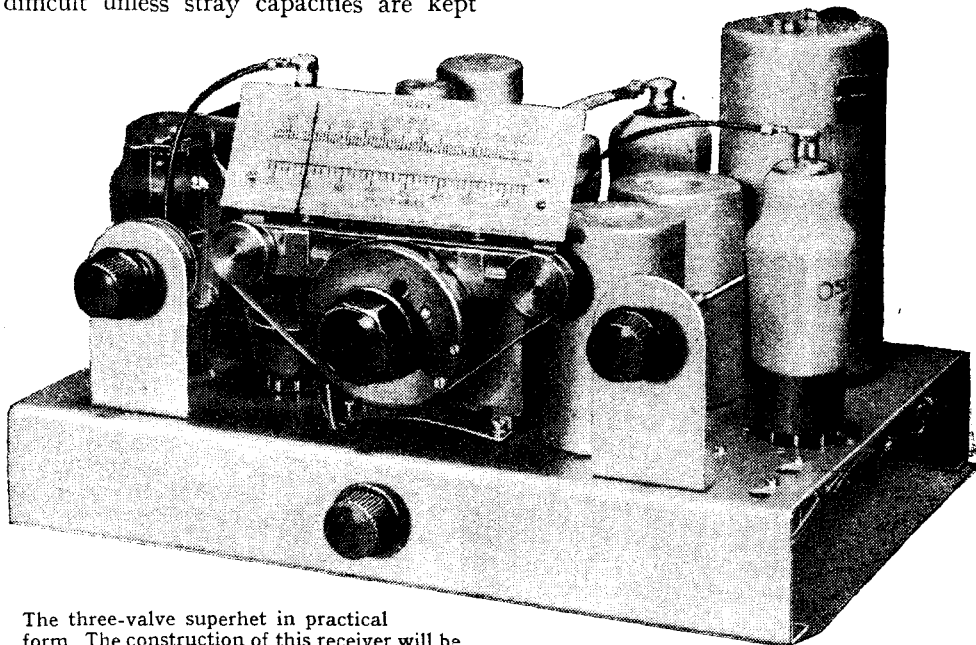

Fig. 4.—The AVC system comes into operation with an input 9 db. above that needed for 50 milliwatts output, and maintains the output at an unusually constant level.

greater. The long wave performance is, in fact, exceptionally good, for in most receivers the sensitivity is much lower on the long than on the medium waveband and varies to a greater degree.

The selectivity at 1,000 kc/s is shown in Fig. 2, and the curve was taken at the optimum setting of the variable selectivity control, that is, the same setting as that used for the sensitivity measurements. It does not, therefore, represent the maximum selectivity, for it can be increased at the expense of sensitivity. The curve shows good selectivity, the response at 10 kc/s off resonance being 1/500 that at resonance on one side of resonance and 1/300 on the other.

It is the fidelity which is so striking for a receiver of this class, however, and Fig. 3 shows that an exceptionally good performance has been secured. With low selectivity the response falls by only 6 db. at 8,000 c/s and by 3.6 db. at 30 c/s. The curves have been taken with a constant resistance load and consequently do not show the rise in the treble which occurs when the output pentode is associated with a loud speaker, and which still further improves the performance. With optimum coupling in the IF transformer the treble response naturally falls off as indicated by the dotted curve. The variable selectivity control can thus be used as an effective tone-control should this be thought desirable.



The three-valve superhet in practical form. The construction of this receiver will be described in the next two issues of this journal.

at an unusually low figure. Now, an examination of the problem of second-channel interference shows that on the medium waveband of 550-1,500 kc/s it can only occur from stations in the band of 1,480-2,430 kc/s, and that, except for

compared with the conventional arrangement, is secured. The arrangement adopted will be fully described in next week's issue of *The Wireless World*, and in the meantime it will suffice to say that it consists of inserting in series with the

The Small Superheterodyne—

Fig. 4 shows the performance of the AVC system. It commences to operate for an output of 9 db. above 50 milliwatts (for 30 per cent. modulation), and a change of input of 74 db. causes a change of output of only about 7 db. That is, a change of input power of 25 million to one causes a change of output power of only five to one!

It will be clear from the curves that the performance given by a well-designed three-valve superheterodyne can be extraordinarily high, and this is confirmed by practical tests on signals. The fact that the receiver is small and inexpensive and employs few valves does not mean that its performance is in any way small.

DISTANT RECEPTION NOTES

GERMANY'S latest plan for the extension of its broadcasting service will not, I fear, be very popular in France. In September a small transmitter was installed near Saarbruecken to provide a service for the Saar territory now that it has returned to the German fold. There is nothing much in that, you may say, to provoke annoyance; nor in the fact that by Christmas time the Saar station will have increased its power to 1.5 kilowatts; nor, again, that by the middle of next year a transmitter rated at about 20 kilowatts will come into action. I quite agree; but in the overcrowded medium-wave band there has been one little Naboth's Vineyard ever since the Lucerne Plan was put into operation. Under the original scheme the wavelength of 240.2 metres was assigned to Luxembourg, which was instructed to reduce both its power and its wavelength forthwith. Luxembourg did neither, but maintained its place in the long wave-band by sheer weight of kilowatts.

Here, then, was a channel going a-begging, and the French promptly grabbed it for Juan-les-Pins, or Radio Côte d'Azur, if you prefer its more high-sounding title. Personally, I call it Nice for short. For some time past Nice has been using only 2 kilowatts, but, as I indicated in my last notes, the 60-kilowatt plant is already testing. A 60-kilowatt plant and one of 20 kilowatts can hardly be happy on the same wavelength, particularly if their geographical separation is not too great. Another little problem for the U.I.R.!

Meantime, another of the Ferrié stations is nearly ready to transmit; in fact, it will probably be at work by the time that these notes are printed. This is Marseilles, where the new 120-kilowatt plant is to replace the 5-kilowatt outfit which has given such good service for many years past. The wavelength used is 400.5 metres. It is actually shared with two Finnish transmitters, but their power is so small that one can hardly anticipate any trouble from them. With selective sets the new Marseilles should be very well received, though old receivers may not be able to make anything of it, since the channel lies immediately between those of Munich and Kattowitz, and the latter has the Scottish Regional as its next-door neighbour.

By this time you have probably made the

acquaintance of the rejuvenated Leipzig and its new aerial. The latter is designed to prevent fading within the service area only, but my experience is that it has definitely improved reception of the German station in this country. After all, a station rated at 120 kilowatts and equipped with an aerial 500ft. in height should be able to cover pretty fair distances.

In a very few days you will find that Radio Suisse Romande, or Sottens for short (I am all in favour of the "for shorts," particularly if they show the geographical position of a station), is coming in at very

much increased volume. This is because the power is being raised from 25 to 100 kilowatts. Sottens thus establishes an equality with Bermünster, which in the autumn, winter and early spring is as good a long-distance transmission as you could wish for in this country. The only fly in the ointment, from the point of view of the British listener, is that Sottens occupies a channel next door to that of our North Regional. I am afraid, therefore, that when the latter is giving speech sideband splutter will be inevitable, no matter how selective a set may be.

D. EXER.

Ferranti AC12C Amplifier

THE output stage of the Ferranti AC12C Amplifier consists of two PX25 valves in push-pull and fed from the preceding stage by means of a high-quality transformer with a split

The mains equipment includes a massively built transformer, and two rectifier valves are used to provide the heavy current taken by the output stage.

On test the amplifier was found to give

**High Quality :
AC Operated :
12 Watts Output**

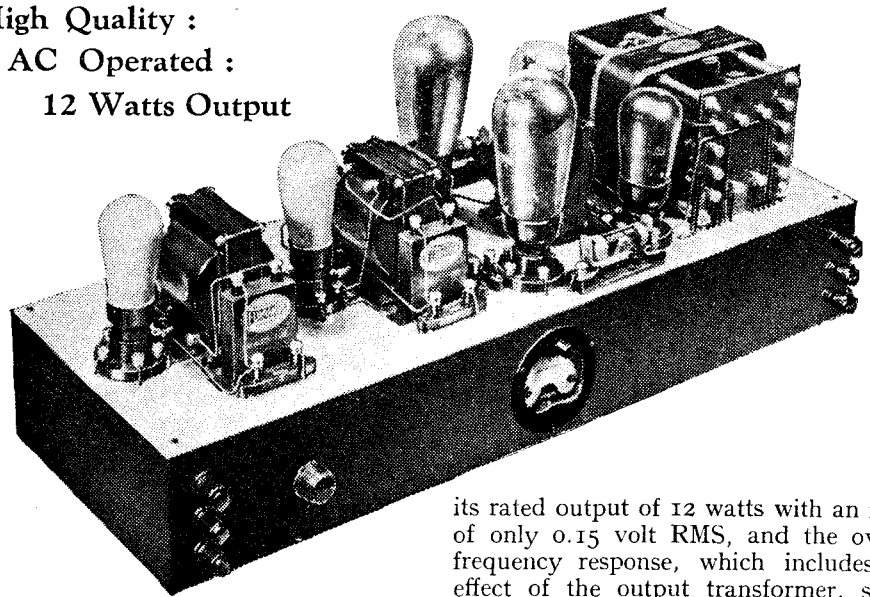

secondary winding. The output valves are run from separate windings on the mains transformer, and not only are they independently biased but their grid circuits are separately decoupled. High resistances are connected across each half of the secondary in order that the transformer may work into a definite load and so give better reproduction of transients.

A D4 type valve is used in the penultimate stage, and the push-pull transformer is resistance-capacity fed from its anode circuit. This method of feeding a transformer is also adopted in the case of the first stage, for which a D4 valve is also used. Here again the transformer secondary is loaded by a resistance. All grid circuits are decoupled, and very extensive decoupling is used in the anode circuits, while a milliammeter is provided which can be switched in to each anode circuit at will in order to check the operating conditions.

its rated output of 12 watts with an input of only 0.15 volt RMS, and the overall frequency response, which includes the effect of the output transformer, shows that a very high standard of fidelity has been reached. At as low a frequency as 20 c/s, the response is +0.65 db., and it only falls to -3 db. at 8,000 c/s. At 10,000 c/s it is -6.8 db. The hum level is satisfactorily low, and when operated with a suitable loud speaker the quality of reproduction attains an exceptionally high standard. The amplification provided is ample for the majority of gramophone pick-ups and many microphones.

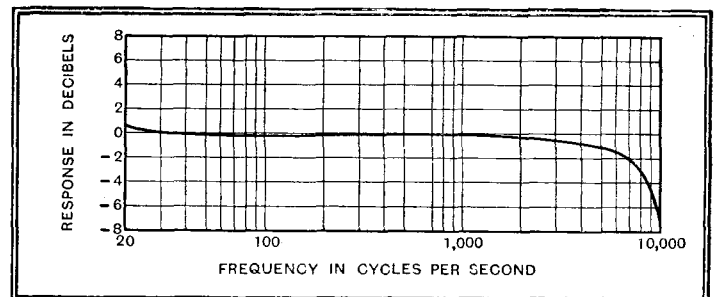

The overall frequency response curve of the Ferranti AC12C amplifier includes the losses in the output transformer.

The amplifier is available as a kit of parts at the price of £26 14s. 5d. including valves. The makers of the parts are Ferranti, Ltd., Moston, Manchester, 10.

Re-Creating an Old Set—I

From "General Purpose" to "Local Station"

By W. MACLANACHAN

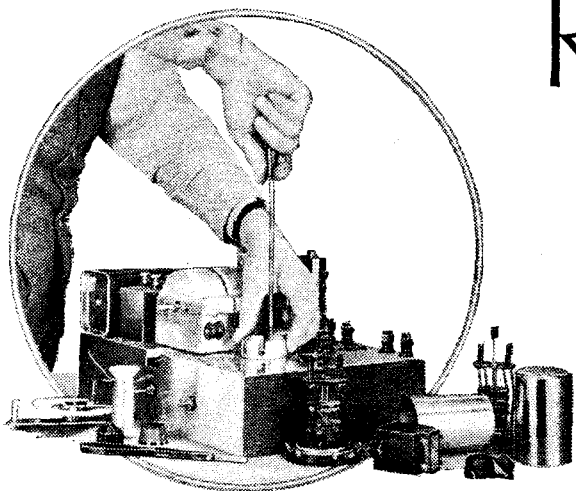

THE author of this article suggests the attractive idea of converting a standard HF-det.-LF set into a short-range quality receiver. Sets which are not current models are extremely suitable for conversion in the manner described, and are now readily obtainable at low cost. Other possibilities in this direction will be discussed in a subsequent article.

It is usually difficult to decide what to do with an old set, whether it is one that has been replaced by a more up-to-date model or one that has been bought because it represented a wireless bargain. There are three alternatives: to use it as it stands, to dismantle it ruthlessly for the components it contains, or to employ the chassis as a basis for experiments.

My own leaning is towards the last of them. A commercial AC set of the straight type that was popular from two to four years ago embodies a compact metal chassis, two or three tuned circuits, a power pack and a cabinet, as well as an energised moving-coil speaker. Whatever is done

with the set, one or two of its valves are likely to be useful. In fact, the cabinet contains the ready-made framework for countless experiments at a cost which equals a quarter to a third of the bare cost of the components.

As the true selectivity of the set is determined by the quality and number of its tuned circuits, any improvement in this direction is likely to prove difficult, as additions are not easily made. The same applies to attempts to increase sensitivity.

On the other hand, the sets that we are discussing lend themselves admirably to improvements in quality. They were originally designed as a fair compromise between sensitivity, selectivity and fidelity

of reproduction, and if the first two qualities are sacrificed to some extent, there is no reason why an old straight set should not be tuned into an experimental local-station quality receiver.

The more or less standard circuit of an AC three-valve set (Fig. 1) includes single- or two-circuit aerial tuning, either tuned anode or tuned transformer coupling to a power grid detector, followed by parallel-fed LF transformer coupling to an output pentode. Of these, the two deterrents to "definition" in the reproduction are the non-linearity of the detector and deficiencies in the LF coupling. When both of these have been eliminated and more satisfactory methods of detection and coupling incorporated, a very noticeable improvement in quality (but at the expense of sensitivity) will be recorded.

The diode valve, although not entirely linear at low HF voltages is, when judged aurally, perfectly linear above four or five volts HF input (RMS). With a good

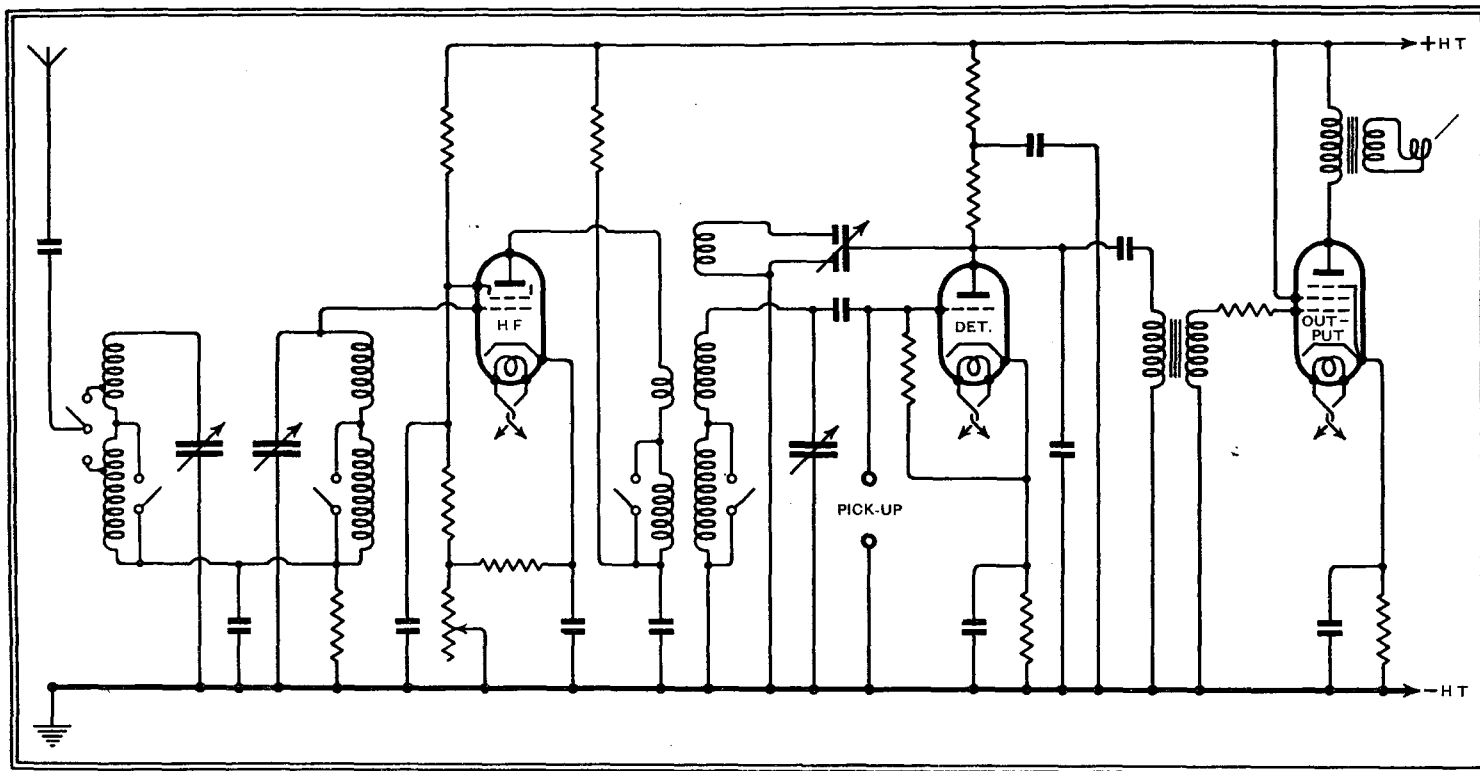

Fig. 1.—Circuit diagram of a typical "standard" HF-det.-LF set which is taken as a basis for conversion.

Re-Creating an Old Set—

aerial and the moderately efficient tuning circuits of the majority of these sets, it is possible in most localities to feed to the diode at least as much voltage as is re-

have bias there is no option but to feed the LF signal from the high-potential end of the circuit. In Fig. 3 the double-diode-triode valve is shown instead of the plain diode of Fig. 2. In this case an HF trans-

grid leak of the valve between the junction C_1 , R_1 and the grid socket. The connections are straightforward, but particular attention should be paid to the load resistance R . This must be returned to the

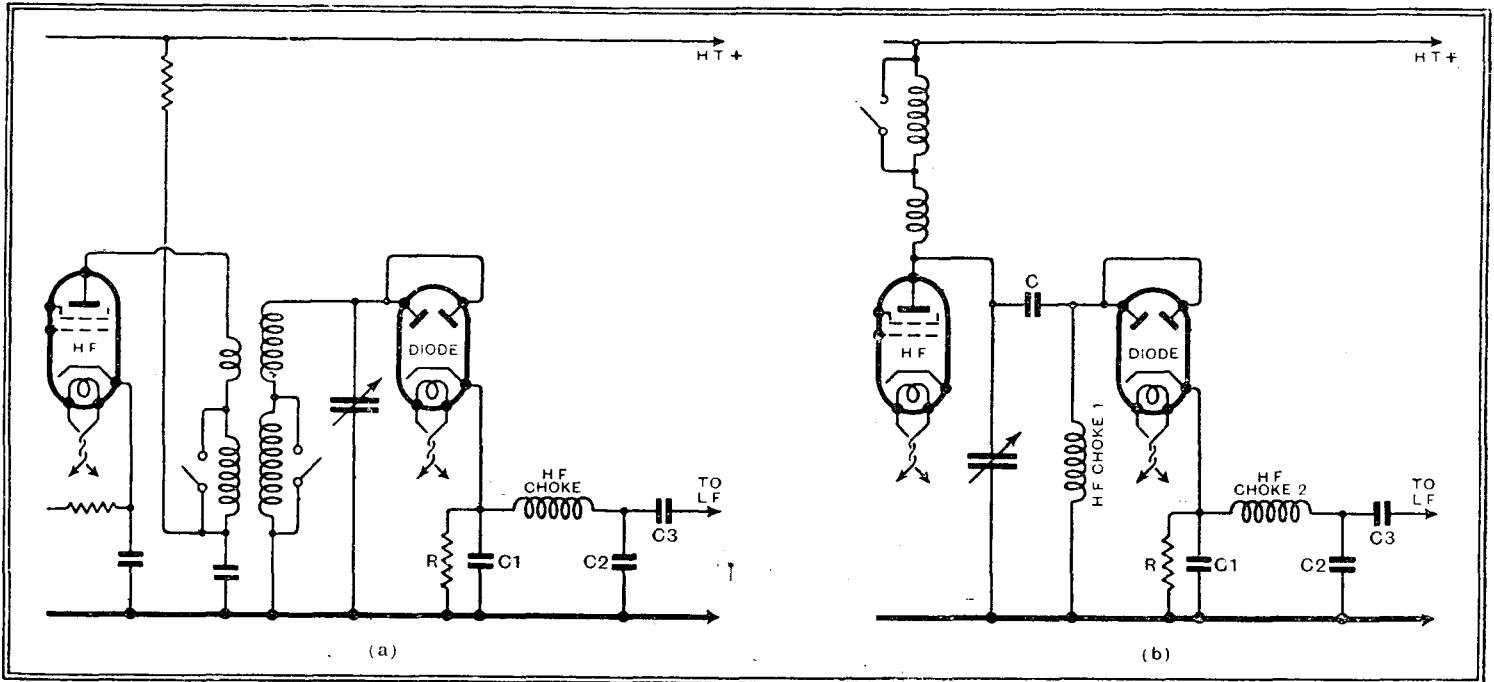

Fig. 2.—Showing conversion of the circuit of Fig. 1 for diode detection. Dia. (b) shows the appropriate alterations for tuned anode coupling.

quired for linear rectification from one if not two stations.

As an initial experiment in modifying a set along the lines under discussion, the circuit of Fig. 2a was used. The detector valve is a simple diode with the anodes connected in parallel, and with a load resistance R inserted in the cathode lead. The coupling to the output or LF valve is through an HF filter, consisting of an HF choke and two condensers C_1 and C_2 of 0.0001 mfd. each, and a coupling condenser C_3 , which may be from 0.01 to 0.1 mfd. The load resistance R may be between 50,000 and 100,000 ohms, and the choke should be screened unless the space available is sufficient to prevent back-coupling with the HF wiring.

In Fig. 2b are shown the appropriate connections for sets with tuned anode HF couplings. The original coupling condenser C should be reduced to 0.0005 or 0.0001 mfd. The other components have the same values as in dia. a, and bear corresponding reference lettering.

Sometimes a much larger input to the detector can be obtained from an HF pentode, such as the five-pin VMP4, suitably biased to between 1.5 volts and 1.75 volts. In the "swamp area" of a local station a single HF valve of this type can fully load an output triode of the PX4 type on peak modulation through the intermediary of a diode rectifier.

Where the signal strength from the station is not adequate, the substitution of a double-diode-triode valve for the power grid detector will usually provide sufficient power to fully load the output valve on mean modulation. In this case, as the grid of the triode section of the valve must

former is employed, but the connections for tuned anode coupling are basically the same. The components are: R , the diode load of 50,000 to 100,000 ohms; C_1 , the coupling condenser, 0.01 to 0.05 mfd.; R_1 , the grid leak of the triode section, 0.25 to 0.5 megohm. As an additional precaution against HF filtering through to the LF part of the set, it is advisable to include

cathode and not to chassis, as in this latter event the diode anode would be biased negatively with relation to the cathode, and a serious loss of power would result.

Improved Quality

A further experiment which increases the quality to a still greater extent is shown

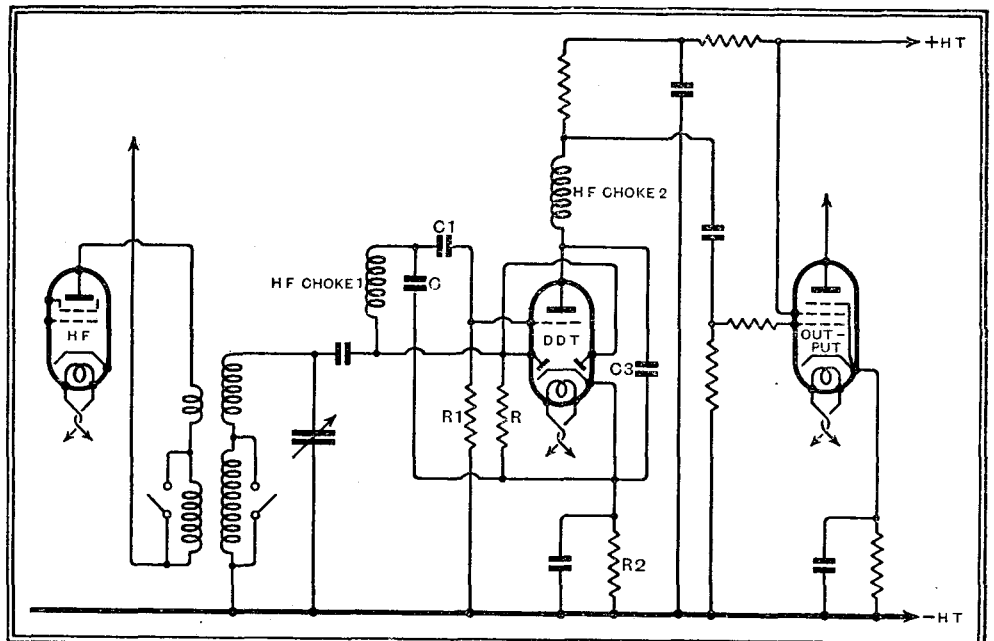

Fig. 3.—Showing the use of a double-diode-triode. Resistance $R_2 = 700$ to 1,000 ohms, depending on valve used. By-pass condenser $C = 0.0001$ mfd.

an additional screened choke No. 2 or a 2,000-ohm resistance with an HF by-pass condenser C_3 of 0.0001 mfd. to 0.0002 mfd. Alternatively, an HF stopping resistance may be connected directly into the

in Fig. 4. For this arrangement room must be found on the chassis for an extra valve-holder. As before, the method can be used with the alternative connections of Fig. 2 for transformer or tuned anode

Re-Creating an Old Set—
coupling. A separate LF valve is employed; this should be of the low-imped-

current without overheating, quality experiments can be continued further by substituting a PX4, PP3/250, ACO44, or

no mean fashion, and the surprises of ten metres culminated in the remarkable happenings on Sunday, October 13th.

On the previous Sunday the Belgian station ON4AU made what is believed to be the first two-way contact with Australia on the 10-metre band. Over a score of North Americans were heard, together with the Argentine stations LU1EP and LU9BV.

Early on the morning of October 13th the low-power British station G6LK, at Cranleigh, Surrey, made the first contact between this country and Australia by working VK2LZ, operated by Mr. W. E. C. Bischoff at Crows Nest, New South Wales. He followed this up by working with LU1EP (Argentina), OE6DK (Austria), and FA8CR (Algeria), thus working with four continents in a few hours.

During the afternoon ZS1H (South Africa) was heard at R7, R8, and R9. Other stations heard were VS6AH, at Hong Kong, VK4BI, another Australian, and thirty-seven North Americans.

All six continents were heard during the day. So much for the excellent work of Mr. Laker, G6LK.

Japanese Reception in London

G5FV and G2HG are also known to have worked with several North Americans, and two receiving stations in South London report having heard Japanese stations in addition to most of the others mentioned above.

One of the peculiarities of this work was that throughout the day the 20-metre band did not appear to be particularly good—if anything, conditions were below normal. In 1928 and 1929—when the last long-distance contacts on 10 metres were made, prior to this year—10 metres was never good unless 20 metres was quite exceptional.

We are now awaiting with interest the first official proof of the existence of a reflected wave on 5 metres!

In conclusion, it is only fair to point out that most of this great interest shown in 10-metre work this year has been aroused by the International 10-metre Contest, organised by the Radio Society of Great Britain. MEGACYCLE.

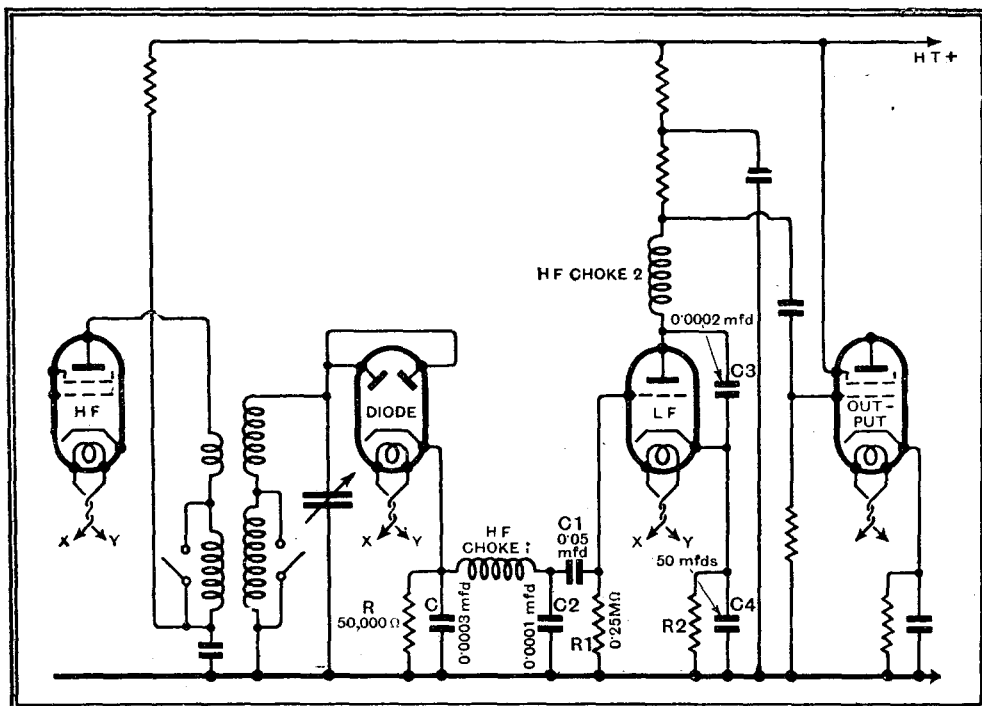

Fig. 4.—The addition of an intermediate LF stage, using a valve of low impedance. The modifications of Fig. 2(b) will apply to sets with tuned anode coupling.

ance type, such as the MHL4, 164V, or even the ML4. Any of these valves are capable of accepting a sufficiently high voltage on the grid to ensure that the diode is operating on the linear portion of its characteristic, and, with the low-impedance valve resistance coupled to the output stage, there should be no appreciable falling off in the top-note response below 9,000 or 10,000 cycles. The limit will usually be set by the HF tuning circuits and the speaker.

For the full retention of the bass response the cathode by-pass condenser of the LF valve should be of the small 50-mfd. electrolytic type with a voltage rating sufficient for the grid voltage to be applied to the valve. As with the double-diode-tiode, it is advisable to include an HF stopping choke (No. 2 in the diagram) in the anode circuit of the LF valve with an accompanying by-pass condenser C3.

Extra Components

Although the chassis of a commercial set may appear to be so crowded that it seems impossible to add further components, by the discreet use of small condensers and resistances suspended in the wiring substantial variations of the circuit can be accomplished. In the case of additional valves, a practical way out of the difficulty of cutting an extra hole for the valve-holder is to use one of the "above baseboard" type, drilling holes for the leads and insulating the terminals from the chassis by a flat piece of bakelite or fibre.

Provided the mains transformer is capable of giving a substantial increase of

LP4 for the pentode output valve. This change, of course, involves considerable alteration of the HT circuit and demands more effective decoupling, but there are many sets in which it can be advantageously carried out.

Ten-Metre Reveillé

MANY of us have been predicting that startling things would happen on the 10-metre amateur band before the end of 1935. Since the beginning of this month they have been happening in

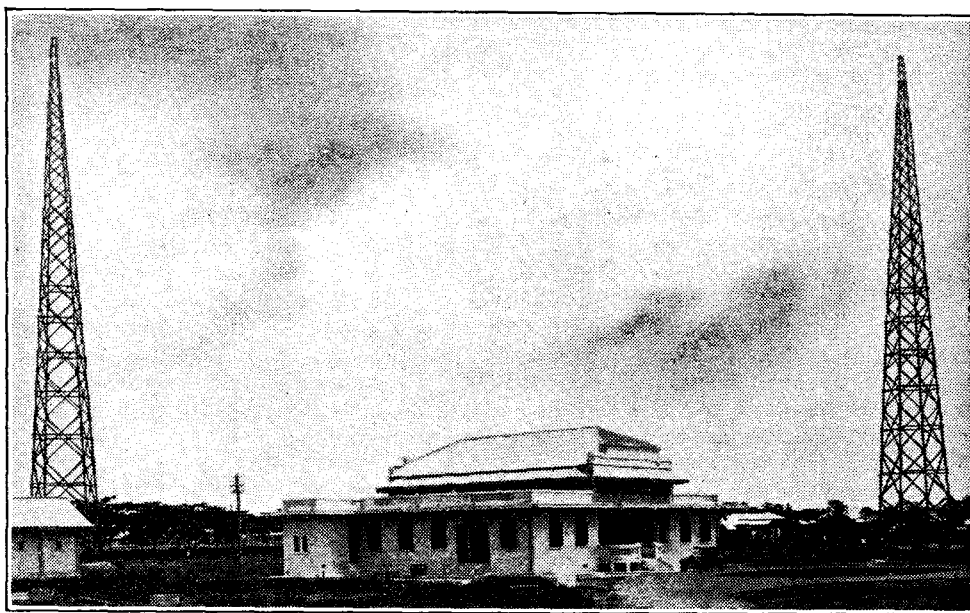

LINK WITH THE OCCIDENT.—The Telefunken short-wave station at Bangkok (Siam) which maintains a constant service with Europe and America.

Listeners' Guide for

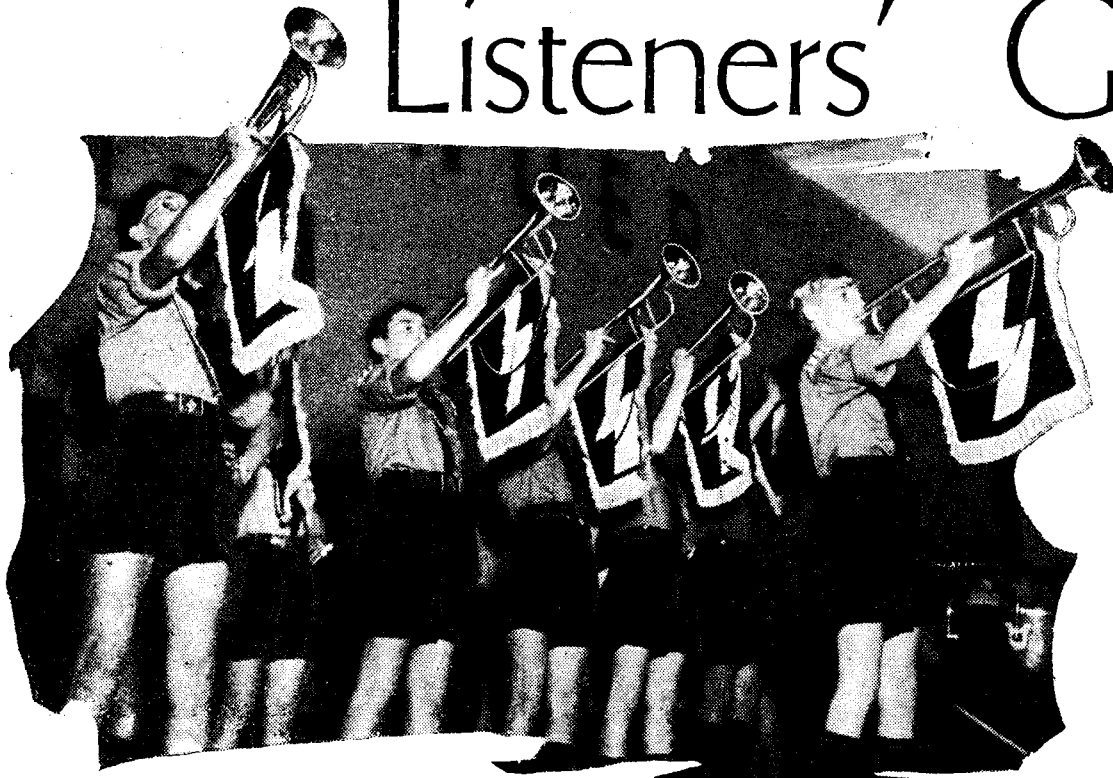

FROM THIRTY-ONE COUNTRIES

MORE than 400 transmitters are participating in Sunday's international feature, "Youth Sings Over the Frontiers," the biggest world broadcast ever staged. The idea was suggested to the International Broadcasting Union by the Hitler Youth Organisation of Germany, and accordingly Berlin has been entrusted with the technical organisation of the programme.

Youthful choirs of thirty-one countries will each broadcast for 3½ to 4 minutes between 5 and 7 p.m. This will call for meticulous timing arrangements at the Berlin control point. Two distinct cable networks have been arranged, one for the relay of each programme to Berlin and the other for re-radiation from the centre to all transmitters participating.

OVERSEAS RECORDS

The British programme, from a studio in Broadcasting House, will be provided by an anonymous choir of boys and girls and also a choir of Boy Scouts. Nearly all European countries will contribute, and a number of overseas stations will also take part. In some cases, owing to time differences and unreliability of radio contacts at that time of day the items are being relayed to Berlin tomorrow (Saturday) to be recorded and grafted into the transmission on Sunday.

Probably no better demon-

YOUTH AT THE MICROPHONE. Thirty-one countries participate in the great international programme, "Youth Sings over the Frontiers" which the B.B.C. relays in the Regional wavelengths on Sunday. The focal point of the relay is Berlin and above are members of the Hitler youth organisation who will contribute to the programme.

stration of good will between the youth of all nations could be given than this; perhaps it foreshadows a time when the adult populations will also feel ready to sing over the frontiers.

The B.B.C. will relay the feature between 5 and 6.30 p.m. (Regional).

IN SMALL PRINT

EVENTS which are unimportant in the opinion of a newspaper editor go to make up the small print column. Very often the happenings described are enormously important for the people actually concerned.

This is the idea behind "In Small Print," a radio play which will be broadcast on Monday and Wednesday next. The play, which is founded on the Polish drama by Eleanore Kalkowska, is divided into five short scenes arising out of five little news cuttings as follows: A postcard sixteen years in the post; the suicide of a young musician; the Chancellor of the Exchequer acknowledges conscience money; a girl convicted of stealing a watch; a British firm gets a contract.

While the cast includes many old-established names such as Beatrice Gilbert, Philip Wade, Eliot Makeham and Vivienne Chatterton, an exception will be John Gabriel, a recent discovery of the producer, Lance

Sieveking. A great acting future is prophesied for this young student from the Royal Academy of Dramatic Art. (Monday, Reg., 8.15; Wednesday, Nat., 8.45.)

REALLY "ALL-STAR"

THE stage is now set for the first of the autumn Gala Variety shows to-morrow night at 8 (Nat.). The show will run for 90 minutes with a bill including Renée Houston, fresh from her success

in "Love Laughs" at the Hippodrome, and Arthur Young, the brilliant pianist, whose combination, "Arthur Young and his Youngsters," is said to rival the hottest units on the other side of the Atlantic. Also we shall hear Jean Sablon, of "Bœuf

ANNA STEN, the famous Russian film star, is the distinguished guest in the "Red Sarafan" programme on Tuesday. This is how she appeared in "Lady of the Boulevards."



Sous les Toits," where he commands one of the best-known quartets in Paris, and Adelyn Pitzell, a protégé of Toscanini. Nat Gonella, the brilliant band leader, will be there, and Jack Mackintosh, the cornet player of the B.B.C. Symphony Orchestra.

This is one of those rarities, a genuine "all-star" programme.

B.B.C. ORCHESTRA IN WALES

SWANSEA will pay a graceful tribute to the B.B.C. Symphony Orchestra when it arrives there on October 31st, for it will be met by the Mayor, conducted to the Banqueting Hall and entertained to a civic luncheon.

The concert, which will be broadcast from the Brangwyn Hall, will include Mozart's Symphony No. 40 in G minor and "Wotan's Farewell and Magic Fire Music" from Wagner's "Die Walkure." A feature will be the playing of "Land of My Fathers," scored for the first time for full orchestra. Dr. Adrian Boult will conduct. (Nat., 8.)

ANNA STEN TO BROADCAST

ANNA STEN, the Russian film star, is the distinguished guest at the "Red Sarafan" on Tuesday (Nat., 8). The Siberian Cossacks are busy piecing together traditional songs

the Week Outstanding Broadcasts at Home and Abroad

HIGHLIGHTS OF THE WEEK

FRIDAY, OCTOBER 25th.

Nat., 8, Violoncello Recital by Nikolai Graudan. 8.30, Kentucky Minstrels. 10.20, "Congo Landing."

Reg., 7.30, Coleridge-Taylor Programme. 8.30, B.B.C. Organ Recitals—I (G. Thalben Ball). 9.15, Alfredo Campoli Trio.

Abroad.

Brussels I, 8.15, Gala Symphony Concert commemorating Yser battle.

SATURDAY, OCTOBER 26th.

Nat., 8, Gala Variety Programme. B.B.C. Orchestra. Henry Hall's Hour.

Reg., 7.55, "Savitri" (Holst) from Sadler's Wells. Recital by Daisy Kennedy (violin) and Adolph Hallis (pianoforte).

Abroad.

Leipzig, 7.10, Opera: "Aennchen von Tharan" (Strecker).

SUNDAY, OCTOBER 27th.

Nat., 2.45, B.B.C. Northern Ireland Orchestra. "The Apostle Play" (Max Mell). 9, Leslie Jeffries and Orchestra, Grand Hotel, Eastbourne.

Reg., 5, Youth Sings Over the Frontiers. Service from Newcastle Cathedral. Sunday Orchestral Concert.

Abroad.

Kalundborg, 9.10, Operetta concert by the Radio Orchestra.

MONDAY, OCTOBER 28th.

Nat., 8.30, The Air-do-Wells. Spencer Dyke String Quartet.

Reg., Old Time Ballad Concert. 8.15, "In Small Print"—a radio drama. Symphony Concert by B.B.C. Orchestra.

Abroad.

Leipzig, Berlin, 8, New German Light Music (substitutes for jazz).

TUESDAY, OCTOBER 29th.

Nat., 8, "At the Red Sarafan." B.B.C. Dance Orchestra. Recital by Eda Kersey (violin) and Keith Falkner (baritone).

Reg., 6.30, Air-do-Wells. Leslie Bridgewater Quintet. B.B.C. Symphony Concert.

Abroad.

Leipzig, 8.20, "Musical Fireworks" (from Dresden).

WEDNESDAY, OCTOBER 30th.

Nat., B.B.C. Dance Orchestra. Gramophone Records: "The Tortoise and the Hare." 8.45, "In Small Print."

Reg., London String Players. 9.15, B.B.C. Variety Orchestra. Roy Fox and his Band.

Abroad.

Warsaw, 8, Chopin Concert by Station Symphony Orchestra and soloists.

THURSDAY, OCTOBER 31st.

Nat., 8, B.B.C. Symphony Orchestra at Swansea. Gershon Parkington Quintet.

Reg., Tunes of the Town—3 (Comper: John Watt). 8.15, "Squibs"—a musical programme.

Abroad.

Kalundborg, 7.10, Sixth Thursday Concert from the State Broadcasting Building.

which have not been heard in this country, and they will have the help of Emilio and his Red Sarafan Orchestra. As usual this brilliant feature will be under the direction of Capt. Vivien, Marquis de Chateaubrun.

"DIE MEISTERCROONER"

A MUSICAL battle will be fought in the Copenhagen studio to-morrow night (Saturday) from 9 to 10. In this "Night of Youth" each member of the radio dance band will compete for listeners' top votes, and afterwards some popular crooners will begin a song contest. This sounds like "Die Meistersinger" in modern dress.

OPERA ABROAD

THE world's greatest and more resourceful libertine, Don Juan, is honoured by an unusually attractive programme offered to-night at 8.30 by Paris PTT and Lille. It is entitled "The Legend of Don Juan," and the first part will consist of Molière's play, followed by Mozart's immortal "Don Giovanni."



LUCIANO LOPEZ and his orchestra, one of Switzerland's versatile bands which play jazz, Tyrolean comedy numbers and Italian operatic selections. The band will be heard in the Motala programme to-morrow (Saturday) between 9 and 10 p.m.

To-morrow's principal opera transmission is "Aida" (Verdi), which Rome will broadcast at 7.50. Those who prefer lighter fare can

listen to Mozart's "Cosi fan tutte," which Berlin is relaying from the State Opera at 7.

The Deutschlandsender offers the unfamiliar modern opera, "The Village Barber" (Dombrowski), at 7 on Sunday. Mussorgsky's "Boris Godunov," which was virtually a failure when first produced in 1874, was re-orchestrated and turned into a brilliant success by Rimsky-Korsakov. Brussels No. 1 is giving excerpts on Tuesday.

FOLK MUSIC

NATIONAL music has a good showing this week-end. Prague celebrates Czechoslovak Music Week with a gala concert of folk music, to be broadcast at 7.55 this evening (Friday). A really notable programme comes from the Deutschlandsender at 6, when the "Five Nürnberg Singers" render German national songs with interludes of pianoforte and oboe music. The same station offers "Scenes from Bavarian Folk Life" at 8.15 p.m., with characteristic songs and music. On the same evening at 8.15



W. G. GRACE. Reminiscences of the great cricketer will be given this evening (Nat. 10) by Mr. A. C. Maclaren in the "I Knew a Man" series. Above is the famous "Vanity Fair" caricature by "Spy."

songs and dances will be broadcast by Berlin (Funkstunde) at 5.15 on Saturday.

NOVELTIES

FRIDAY, 9.5: Literary Programme in English (Moscow No. 1).

Saturday, 4.45: League of Nations talk in French on "The British Empire and Peace" (Brussels No. 1).

Saturday, 9.30: Cor Anglais Recital (Deutschlandsender).

Tuesday, 5.30: Dr. Goebbels' 38th birthday programme (Frankfurt).

Thursday, 10: Handel's "Perseus and Andromeda"—recorded version of B.B.C. broadcast on October 8th (Munich).

JAZZ SUBSTITUTES

Now that Germany has banned jazz bands other forms of light music have had to be found. At 8 on Monday Leipzig and Berlin will give a *première* performance of the new styles of German dance music.

JUST MARRIED

"COOING in an Attic Flat" is the attractive title of an "O.B." which Copenhagen will relay on Monday from 8.45 to 9.15. The microphone will pay a visit to an anonymous young couple "just married." THE AUDITOR.

UNBIASED

Vocational Sets

THERE appears to be a far greater demand for what I may term "vocational" receivers than I had at first supposed. Old readers will remember that a week or two ago when discussing portable receivers I referred to the fact that I possessed several of these, designed in different shapes to suit different occasions.

As a result of my brief note I have received a large number of letters from readers asking me where they can obtain receivers of a similar type. These demands go considerably beyond my own ideas, however, since many readers require specialised receivers for ordinary domestic use and have apparently been searching for them for a long time.

Thus, a well-known authority on motor-ing writes to tell me that for a long time past he has been trying to get a receiver in which the main tuning control is in the form of a steering wheel and the whole of the control panel modelled on the dashboard of a car. On the other hand, the

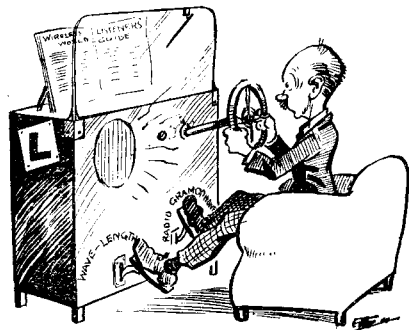

Specialised receiver for ordinary domestic use.

skipper of a popular tramp steamer tells me that he would gladly give six quids of smuggled tobacco for a receiver in which the tuning knob and dial were made up in the semblance of a ship's wheel and a compass card respectively; he states rather pathetically, however, that he supposes that his wants will continue to go unsatisfied, as he has searched all his life for a domestic clock which struck eight bells instead of the ordinary strike and even such a simple thing as this is apparently unobtainable.

I must say that these unfortunates have my very lively sympathy, but I fear that I am quite unable to tell them where they can get their wants supplied. If you want a thing done, do it yourself, is a highly applicable motto.

Breaking a Promise

IT has always been my proud boast that I am a man of my word and to fail in fulfilling a promise means almost as much to me as the loss of life itself. It is therefore with considerable perturbation of

soul that I face a crisis in my life which bids fair to reduce me to the level of a politician. Irony is added to the whole affair because the unfortunate position in which I find myself is due to the overwhelming prosperity of the radio trade—a situation which, although I say it as shouldn't, is in no small measure due to my own efforts.

My trouble has arisen out of the fact that, in a weak moment, I promised to present a couple of dozen of the very latest wireless sets to the women's institute of the village near which I live, the idea originating with the vicar, who had some foolish idea of thereby counteracting the gossiping tendencies of the women using the institute.

In order to fulfil my promise I sent out for a complete set of this year's catalogues, and after a careful study made my choice. I was just about to post my order when my eye was caught by the report of the Olympia Show in an old newspaper containing my humble evening meal. It appeared that the firm whose set I had chosen had sold the whole of their factory output for a year within an hour of the Show's opening.

Appeal to Sir Galahads

Somewhat reluctantly, therefore, I made a second choice, but was again dismayed to find that the products of this firm also were not available to me, for, although no mention was made of their selling their complete year's output, this could naturally be assumed, an official of the company having informed a reporter that they had done over a quarter of a million pounds'-worth of business during the first day of the Show. Somewhat similar stories were told of a third and yet a fourth firm, and in desperation I sped up to London to consult the back numbers of a well-known London daily and speedily discovered that there was not a solitary set manufacturer who had not sold at least six months' output in advance.

You will therefore appreciate my dilemma and the grave risk of my being guilty of breaking a promise. I feel sure, however, that even in these days of sex-equality there are many of you with enough of the spirit of Sir Galahad remaining to induce you to give up your seat to a woman in a public vehicle, and I feel sure that the same spirit will induce you to respect my grey hairs and to give up your place on the waiting list for one of this year's sets. Do not disappoint me.

Run of Bad Luck

I SUPPOSE that, at some time or another, most of us have railed against the B.B.C. programmes on the score that they were too bright or that they were too dull, or something like that. In particular, I have noticed that our leading set manufacturers have given tongue with great frequency, moaning that the B.B.C.'s programme policy crabs the sale of their products.

In spite of all their moaning and groaning, however, none of the manufacturers has hitherto done anything concrete about it, but at last, I am pleased to see,

By FREE GRID

one of them has bestirred himself and has produced a receiver wherewith we can beguile the weary hours while the B.B.C. is churning out its customary Sunday fare. Unfortunately, however, the receiver has already been the direct cause of my losing a great deal of my hard earned cash in a manner which I shall explain herewith.

The machine is a highly ingenious instrument which will, if its tuning dial is not adjusted to any particular station, promptly tune itself to the one which is nearest in wavelength. If set so that it is tuned midway between two stations which are adjacent in wavelength and equal in power, each station will try with equal force to pull it into tune in opposite directions, and so nothing will happen.

In actual practice, however, before long one of them is bound to fade, and in spite of the efforts of AVC it will always happen that suddenly there is a stronger pull from one than the other, but which one is entirely on the knees of the gods, and it is up to participators in this entertaining game to back their fancy. Although admiring the ingenuity of the manufacturer who devised this method of passing away the hours of chamber music I must confess that I have had an extremely bad

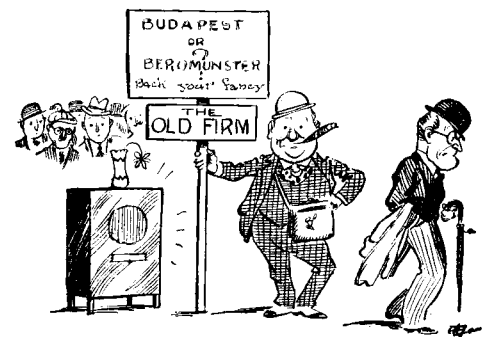

Extremely bad run of luck.

run of luck and at the present moment I am actually stuck for the price of a stamp and shall have to post this contribution to the Editor, trusting to his good nature to pay double postage at the other end. I consider that, in common fairness, the manufacturers of this receiver ought to refund the postage to me so that I may pass it on to the Editor.

LOUD SPEAKER OVERHAULS

Practical Wrinkles for Improving the Results from Second-hand Units

A COMPLETE breakdown in a loud speaker generally calls for a new unit or the services of the professional repairer, but there are many cases of slight deterioration through age which can easily be remedied by the amateur mechanic.



The removal of dust and filings from the gap is best accomplished with the aid of cotton wool soaked in vaseline.

OF the many component parts which go to the making of the modern set, the moving-coil loud speaker is probably one of the most reliable. The low-resistance speech coils which have now been in use for several years give far less trouble than the high-resistance windings of the earlier moving-iron type instruments. Any troubles which may be experienced with a moving-coil loud speaker are therefore more likely to be of a mechanical character, and even then are likely to show themselves as a progressive deterioration of performance rather than an abrupt and complete breakdown.

One of the most common sources of trouble is dust in the air gap. Nowadays most manufacturers take adequate precautions to protect the gap either by flexible covers incorporated with the centring device or by enclosing the whole unit in a muslin bag; but the loud speaker of two or three years ago had no such protection, and by this time is almost certain to have collected a fringe of mixed dust and filings which at the best will introduce irritating "brushing" noises, and at the worst may actually abrade the insulation of the speech coil winding. A large proportion of this dust is iron, and where it all comes from is something of a mystery, but there it is, and Boreas himself would fail to dislodge it by mere blowing.

To make a thorough job of cleaning the gap the diaphragm will have to be removed. Although this may seem troublesome it will be well worth while, for the gap can at the same time be examined for any signs of rust. This is often to be found even in magnets with plated pole pieces, and is more prevalent in energised than in permanent magnet speakers

as moisture is given off from the field winding if it has not been properly baked and impregnated.

Cotton wool soaked in vaseline and twisted into a spill thin enough to reach the full depth of the gap is the best medium for removing dust and filings. A thin strip of card may be used to push the spill round the gap, and the wool should

be withdrawn progressively as it is worked round. A final wipe with a dry spill will remove any excess grease, leaving a film sufficient to deter the spread of rust but not enough to collect further dust.

The speech coil itself should be wiped carefully, and the diaphragm can then be reassembled for a test to see if the spurious noises have disappeared. For the purpose of this test the possibility of obtaining 10 to 50 volts AC at 50 cycles from the tappings of the mains transformer of the set should not be overlooked. The test voltage should, of course, be applied to the primary of the output transformer, and this method must be used with caution as, although there may be only 10 volts between the tapping selected, the leads may both be at a potential near the full mains voltage above earth. If spurious noises persist (other than harmonics resulting from excessive amplitude of the diaphragm) they will probably be traced to faulty seams in the diaphragm or loose joints in the fixing of the centring spider. The junction of the speech coil former with the apex of the diaphragm is another vital point which must be quite solid. A suitable "dope" for strengthening joints or closing minor tears in the diaphragm is

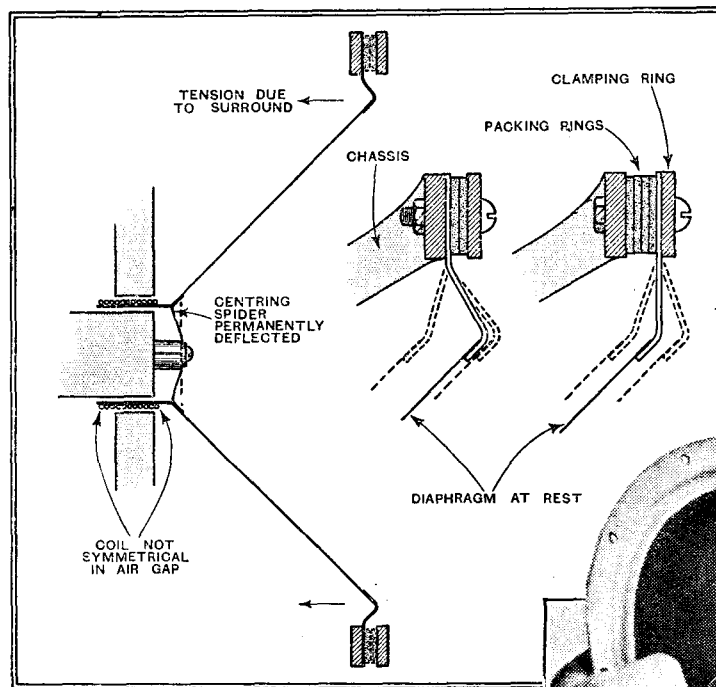

Poor bass response and harmonic distortion may be caused by tightening of the surround.

be withdrawn progressively as it is worked round. A final wipe with a dry spill will remove any excess grease, leaving a film sufficient to deter the spread of rust but not enough to collect further dust.

The speech coil itself should be wiped carefully, and the diaphragm can then be reassembled for a test to see if the spurious noises have disappeared. For the purpose of this test the possibility

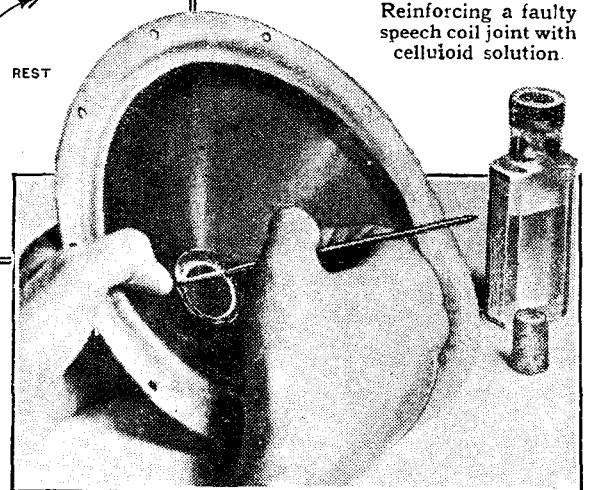

Reinforcing a faulty speech coil joint with celluloid solution.

easily made by dissolving celluloid shavings in amyl acetate—a liquid obtainable from any chemist or druggist. The celluloid takes several days to dissolve completely, and it should be added a little at a time until the liquid is of the

Loud Speaker Overhauls—

consistency of thin treacle. A camel-hair paintbrush may be used to apply the "dope" to any spots which are suspected of causing rattles, and from 12 to 24 hours should be allowed for the cement to set before retesting.

Incidentally, an old type speaker which is deficient in high-note response may often be improved by painting a small area of the diaphragm near its junction with the speech coil with a diluted solution of the celluloid. But it is advisable to make sure that the loss of top is actually in the speaker and not in the set or output transformer before resorting to this expedient.

The best method of centring the coil when the diaphragm is reassembled in the chassis is a matter of debate. Some people advocate the use of temporary packing strips of thin card distributed at equal intervals round the gap, but if the speech coil is slightly warped it may return to its elliptical form and touch the sides of the gap when the strips are withdrawn. Generally speaking, it is better to centre the coil by eye when any such irregularities of shape can be allowed for.

An adjustment of equal importance, but one which is frequently overlooked, is the centring of the coil in the gap in a direction parallel to the movement of the diaphragm. Not only is it important that

the movement of the coil should be symmetrical with regard to the stray field inside and outside the gap, but the restoring force exercised by the diaphragm and centring device should be the same for equal deflections inwards and outwards from the position of rest. It does not require a very sensitive touch to test for this condition by gently deflecting the diaphragm in both directions by hand.

If through some fault of previous assembly or on account of tightening of the surround with age the movement is restricted more in one direction than the other, the tension should be relieved by inserting packing washers under the clamped edge of the diaphragm and also under the holding-down screw at the centre of the diaphragm if necessary. An alternative procedure might be to put washers under the holding-down screws between the cone frame and the magnet. The two conditions that must be satisfied if this adjustment is properly made are (1) that the overlap of the ends of the speech coil in the gap must be equal, and (2) that both the centring spider and the outer surround must be slack when the diaphragm is at rest.

With attention to these few details there is no reason why the original performance of a moving-coil loud speaker should not be restored or even improved upon.

with output power. We also noted in passing that the power by itself cannot bring much joy; the volume of sound actually discernible by the senses depends on the efficiency of the loud speaker. So without some knowledge of the loud speaker we are sunk; we cannot say how much sound will be turned out by a stated number of milliwatts—the units of power.

Measuring Sound Intensity

There *are* units of sound, but they are so difficult to measure accurately and informatively that they are used only by very highly technical people. Fortunately, however, the efficiency of all ordinary domestic loud speakers comes within fairly narrow limits, as nearly as can be judged by ear; so one can get a reasonably good idea of how many milliwatts are required without complicating the matter too much with loud speakers.

One thing that does complicate the matter very considerably is that a low-note milliwatt does not go nearly so far with the ear as one of a high note. Assuming an averagely efficient speaker in a modern room of strictly moderate size, 100 milliwatts of B.B.C. tuning note—as it is chopped up into six pips for time signals—is almost intolerable. But 100 mW. of bass notes is not at all adequate for giving an impression of massed 'cellos and double basses in the Queen's Hall, being no more than a gentle murmur.

The output power of the usual type of modern mains-driven set is in the region of 2,500 mW. Knowing this, one might think that 150 mW. would be hardly audible. Yet the latter figure is typical of portable battery sets, which are by no means inaudible. One explanation of this curious fact is that the difference between 150 and 2,500 mW. is not nearly so much to the ear as it looks on paper. They might be described roughly in words as moderately loud and very loud respectively. Another explanation is that the low notes, which are those that really require big power to handle them, are mainly strangled at birth in the portable. Another is that there is probably a good deal more distortion going on in the portable, due to the modest allowance being exceeded. But perhaps the most important of all to grasp is that the *average* output, even when the 2,500 mW. set is running "all out," is quite small—perhaps 200 mW. or less. It is rather like allowing head-room for accommodating the surface of the globe above sea-level. One has to leave at least 29,000 feet to get Mount Everest in, whereas the average height of the world's land area cannot be more than 1,000 feet or so.

This being so, in order to get a good turn of volume without financing an exorbitant maximum of, say, 10,000-20,000 mW., some mutilation of the summits of the Everests and Cotopaxis is allowed to take place. The amount of power named is hardly too much, even for domestic purposes, if the exceptional peaks are to be handled comfortably.

mW, μ V and db.

The lbs., yds., and qts. of Receiver Performance

By "CATHODE RAY"

STATISTICIANS of the more pernicious type would doubtless be able to reveal that a hot-air engine twice as large as the Crystal Palace could be kept permanently running on the discussions and arguments as to the capabilities of wireless sets. In these days of ultra-short waves (once more!) there is even a revival of that famous old standard of achievement—"phones on table" strength. Contention and strife are proverbial in relation to fish, which, after all, can soon be put to the test of yardstick and balance. But because a wireless receiver that Mr. Flaming Sparks, of the research department, took home with him last Saturday night brought him in 109 stations (*and* Deutschlandsender clear of Droitwich) is it safe to advertise "109 Stations!" in the newspaper read by Mr. Bill (Slosher) Blerkins, of Diggen-le-Hole? It might not be entirely fair to the firm's district representative.

When Mrs. Blerkins purchases half a dozen yards of material from a mail-order house she can depend on getting the right quantity, because the length of a yard does not depend very seriously on the part of the country or the time of day. Deviations from this rule would cause the Inspector of Weights and Measures to take

an interest in the affair. But it is difficult for a customer to substantiate his statement that the radio set he has purchased is not up to the advertised standard, and equally difficult for the vendor to prove that it is.

Not that standards of comparison are lacking—oh, no! The problem has been dealt with very thoroughly and scientifically, and as regards most of the more important standards there is something approaching general agreement all over the civilised world; much more general than on measures of such simple things as weight and length. The real trouble is that they mean nothing to the plain man, still less woman (the women whose photos we see from time to time in *The Wireless World*, "Only Woman Radio Engineer in Estonia," etc., are, of course, not plain). Our Mrs. Blerkins knows that a 3lb. cod makes a good meal for her family; but neither she nor her husband knows how many milliwatts (abbreviated, mW.) are requisite to fill their back parlour with Harry Roy.

Master Blerkins may conceivably be more helpful, if he has taken full advantage of our educational system. Last week we distinguished clearly the four cardinal virtues of a receiver, beginning



A close resemblance to the type of loud speaker used by the B.B.C. is noticed in this one employed in the "monitoring" control room at Berlin's Broadcasting House.

The milliwatt is the correct unit in which to express the amount of power available for causing the loud speaker to emit sounds. When the Corner Seat on the 8.35 asserts that his set isn't half powerful, while his vis-à-vis replies, Yes, but his gives a deuce of an output, one is still imperfectly informed as to the precise capabilities referred to, and their relation to one another. Hence the need for the mW.

It is surprising, however, how seldom the actual level of output is the thing of interest. This, again, has its parallel with geographical heights. It is a better indication of your achievement to know that you climbed 3,000 feet than to know your height above sea-level at any one moment. In diagrams showing the performance of the various components in a set, or of the set as a whole, the important thing is to know how the output varies over, for example, a range of frequencies. It is no use marking this up in milliwatts, for a drop of 100 milliwatts may mean little or much, according to whether the starting point was 10,000 or 100. It is the proportion of the two that matters. Doubling the output, for instance, produces a very similar effect on the ear whether the original level was large or small. The unit of *change* in level is the decibel (db). The decibel happens—a pure fluke—to be just about the smallest change that you would notice. Even then you only notice it when there is a direct switch-over from one level to the other. To make a to-morrow's First News Bulletin so that you would notice at once that it was louder or softer than today's it might be necessary to alter it by at least 3 db. That is double (or half, if it is minus 3). It sounds a lot—or, rather, it doesn't *sound* a lot; it looks a lot on paper.

Of course ten times the output is really

quite a big jump. That is 10 db. Another 10 db., of course, is ten times again—a 100-fold jump altogether. The difference between very faint and very loud music is 40 to 50 db. To make interference negligible it ought to be at least 40 db., preferably 50, or even 60 below that of the desired programme.

If the mW. is for measuring Power, and the db. is the most useful measure for Selectivity and Quality, the unit for Sensitivity is the microvolt (μV), which is used to denote the strength of the signal derived from the aerial. It might be arranged that the rated sensitivity of a set would be the number of microvolts required to make it give its full complement of mW. at the other end. But then the sensitivity would depend on the power of the receiver, whereas it is desirable to keep these things clear of one another. So it has been agreed that the sensitivity is the number of μV (input from the aerial) required to feed 50 mW. (with volume control at its maximum, of course, and with fixed conditions of modulation) to the loud speaker.

Obviously the smaller the number of μV the greater the sensitivity; in other words, this measure works in the opposite way to the majority of those with which we are accustomed. A set with "a sensi-

tivity of $5 \mu V$ " is twice as sensitive as one with a sensitivity of $10 \mu V$. Receivers can be, and sometimes are, made with a sensitivity better than $1 \mu V$. But sources of noise and disturbance, both within and without the set, are generally about that much or more, so that such a receiver sounds like a locomotive letting off steam. The best sensitivity that is really worth while in a broadcast receiver is more like $5 \mu V$, and even then a "Q" system for cutting out the noise between stations is a distinct blessing.

The common run of commercial broadcast superhets range from 10 to $100 \mu V$ —really enough for general listening, for any stations that are beyond reach of this are most likely to be *really* sour grapes.

Three-valve "straight" sets usually occupy the next decade, from 100 to 1,000 μV . Only fairly "local" stations can provide 1,000 μV from a small aerial, though of course they can go very much higher if they are near and powerful enough.

So now, when you read about a set with a sensitivity of $15 \mu V$ on medium waves, an undistorted output of 5,000 mW., and a selectivity of 40 db. down at 9 kc/s off tune, you will have some idea of what the machine can do!

In Next Week's Issue

THE VARIABLE - SELECTIVITY IV.

An Inexpensive Superheterodyne of High Performance

THE Variable-Selectivity IV incorporates only three receiving valves, a frequency-changer, IF stage and duo-diode output pentode, but through the combination of valves of high efficiency with careful circuit design an outstanding performance has been obtained. The sensitivity is sufficient for full volume to be secured from many Continental transmissions even in daylight, and the selectivity is entirely adequate for normal requirements. The selectivity, moreover, is variable, with the result that an exceptionally high standard of reproduction can be obtained when interference conditions permit. An efficient delayed AVC system is included and greatly minimises fading, while the use of a novel aerial tuning system not only gives better ganging and higher sensitivity, but reduces any possibility of second-channel interference.

The receiver is inexpensive to build and operate; it is designed for AC mains working and is particularly free from hum. Provision is made for the use of a gramophone pick-up, and the set can, if desired, form the basis for a radio-gramophone.

THE LIST OF PARTS

- 1 Two-gang condenser, 0.0005 mfd. Utility "Mite" W347/2
- 1 Dial Utility "Straight Line" W346
- 2 Bulbs for above, 4 volts 0.1 amp. Bulgin 410
- 1 Aerial coil Bulgin 36
- 1 Oscillator coil, 465 kc/s Bulgin C59
- 1 Aerial loading coil Bulgin C42
- 1 IF transformer, 465 kc/s Bulgin C50

- 1 IF transformer, 465 kc/s Sound Sales IF465
 - 1 Mains transformer, Primary; 200/250 volts 50 c/s. Secondaries; 350-0-350 volts 60 mA., 4 volts 2.5 amps. C.T., 4 volts 4 amps. C.T. All-Power PT/BP
 - 2 Trimmers, 0.0003 mfd. Sound Sales 3VC
 - Fixed Condensers.**
 - 3 0.001 mfd. Bulgin PC301
 - 2 0.002 mfd. Bulgin PC302
 - 1 0.003 mfd. Bulgin PC303
 - 1 0.005 mfd. Bulgin PC305
 - 1 0.001 mfd. Bulgin PC201
 - 1 0.005 mfd. Bulgin PC205
 - 1 0.01 mfd. Bulgin PC101
 - 6 0.1 mfd. Bulgin PCP1
 - 1 4 mfd., electrolytic Dubilier 0283
 - 1 8 mfd., electrolytic Dubilier 0281
 - 1 25 mfd., 25 volts, electrolytic Dubilier 3013
 - Resistances.**
 - 2 100 ohms, $\frac{1}{2}$ watt Ferranti G.5
 - 1 150 ohms, $\frac{1}{2}$ watt Ferranti G.5
 - 1 500 ohms, $\frac{1}{2}$ watt Ferranti G.5
 - 1 1,000 ohms, $\frac{1}{2}$ watt Ferranti G.5
 - 1 25,000 ohms, $\frac{1}{2}$ watt Ferranti G.5
 - 2 50,000 ohms, $\frac{1}{2}$ watt Ferranti G.5
 - 1 75,000 ohms, $\frac{1}{2}$ watt Ferranti G.5
 - 1 250,000 ohms, $\frac{1}{2}$ watt Ferranti G.5
 - 4 500,000 ohms, $\frac{1}{2}$ watt Bulgin HW31
 - 1 3,500 ohms, 1 watt Erie
 - 1 10,000 ohms, 1 watt Erie
 - 1 7,500 ohms, 2 watts Erie
 - 1 Tapered volume control, 500,000 ohms Ferranti PG
 - 1 Multi-contact switch Magnum WW7
 - 4 Ebonite shrouded terminals, A, E, and Pick-up (2) Belling-Lee "B"
 - 1 4-pin plug Bulgin P9
 - 3 Valve top connectors Belling-Lee 1175
 - 2 Knobs Bulgin K26
 - 1 Length screened sleeving Goltone
 - 20zs. No. 20 tinned copper wire, 12 lengths systoflex, etc.
 - Chassis, complete with three 7-pin and two 5-pin Clix chassis-mounting valve holders, screws, nuts and washers C.A.C.
 - Valves.**
 - 1 X41, 1 VMP4G, 1 DN41, 1 MU12 Osram or Marconi
 - Loud speaker, 2,500 ohms field resistance and pentode transformer Rola ST603/2500
 - Cabinet C.A.C.
- Approximate cost including valves and cabinet, £12 5s.

New Apparatus Reviewed

Recent Products of the Manufacturers

FULLER HT ACCUMULATORS

FULLER high tension accumulators are made in 10-volt units, each consisting of a glass container divided into five compartments. There are four standard types ranging in size from 3,000 to 10,000 milliamp. hours capacity. The specimen tested is the SDMHG rated at 6,500 milliamp. hours and designed for a safe maximum discharge of 60 mA. It measures $7\frac{1}{2}$ in. long, $2\frac{3}{4}$ in. wide, and $6\frac{1}{2}$ in. high.

Special care is taken in the construction to guard the terminals and lead inter-cell connectors against corrosion, the former having internal grease cups, while the latter are located in a moulded insert let into the

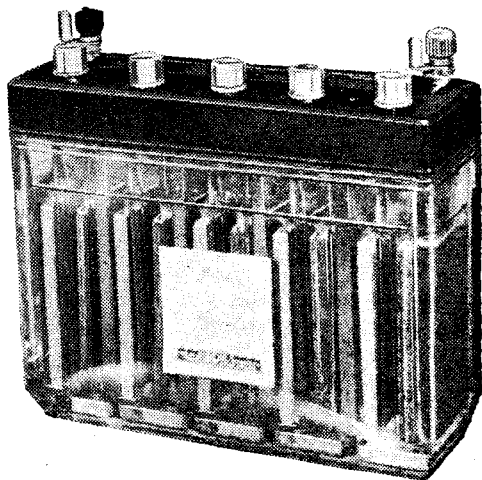

Fuller 10-volt accumulator unit, the type SDMHG rated at 6,500 mA. hours.

pitch compound sealing the top. This is filled with acid-resisting grease and has a transparent cover. On one of the connectors is a tapping socket giving 6 volts measured from the negative end of the unit.

The 10-volt unit was received in a fully charged state, and without a refresher charge was placed on a discharge test at 30 mA. The current was maintained at this value throughout and until the potential dropped to 9 volts, or 1.8 volts per cell, which covered a period of 220 hours. At the discharge chosen this represents an actual capacity of 6,600 milliamp. hours, so that the makers' rating is fully justified and by no means optimistic, but actually erring slightly on the conservative side.

Strongly constructed wooden crates are available to accommodate six 10-volt units, and they are designed so that one can be stacked above the other and locked in position to conserve floor or bench space. Lead inter-unit connecting strips suitably shaped are included.

The type SDMHG 10-volt unit costs 8s., and a crate to hold six 5s. 9d.; this measures $17\frac{1}{4}$ in. long, $8\frac{1}{4}$ in. wide, and $7\frac{3}{4}$ in. high.

The normal charging rate of this size unit is 0.3 amp. It is a sturdily-made battery, and it will give very long service if treated with the usual care and not neglected.

COLVERN SHORT-WAVE COILS

IN the new Colvern short-wave coils the windings are supported on one-inch diameter ribbed formers fitted horizontally in a cradle having four pins spaced to fit a standard valvholder.

This method of mounting enables short, straight leads to be taken from the coils to their respective pins. A heavy gauge enamelled wire with spaced turns is employed for the tuned, or grid, coil, while the reaction winding is in a single slot at the earth end.

A useful feature in the design of the cradle is the provision of two finger grips for removing and inserting the coil.

Three coils are used to cover the short-wave band, they are described as the types U.S.1, U.S.2, and U.S.3, and their ranges are stated to be 14 to 30, 23 to 54, and 42 to 100 metres, respectively.

Our tests were made with an orthodox det.-LF receiver as with this circuit the performance is very largely dependent on the efficiency of the coils and the proportioning of the reaction winding.

The results obtained in the simple receiver were outstandingly good and there is no doubt that the coils are particularly efficient. Reaction was smooth and easily controllable over the whole range of each coil when using a 0.0001 mfd. reaction condenser. A surprising number of c w signals and a few European short-wave broadcast stations were heard with a single detector valve, on headphones, this being possible only by the exceptional smoothness of the reaction.

The measured wave-range of each coil with a tuning condenser of 0.00016 mfd. is 14 to 30.8, 23.3 to 53, and 47.8 to 100.6 metres respectively. As a separate aerial winding is not provided, the aerial was joined to the grid end of the tuned coil through a 15 m-mfd. variable condenser.

These coils cost 4s. 6d. each or 12s. for the set of three.

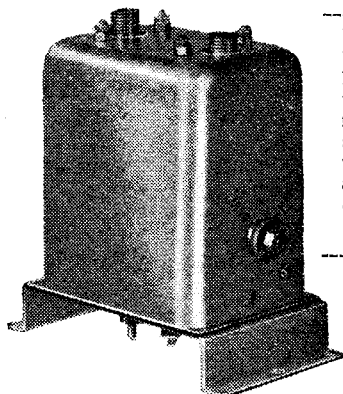

Varley Air Tune 465 kc/s IF transformer fitted with stranded-wire coils and air-dielectric trimmers.

VARLEY AIR TUNE IF TRANSFORMER

THIS new Varley product is designed for use in 465 kc/s IF amplifiers, and, as its description implies, is fitted with air-dielec-

New Colvern short-wave coils for the 14 to 100-metre wave-band.

tric trimming condensers. There are several advantages in adopting this style of trimmer. In the first case, more accurate adjustments can be made, since they are virtually free from backlash, and secondly, as the losses in the condenser can be made relatively small by employing suitable insulating material it is possible to produce a very efficient component. And in the new Varley IF transformer the use of iron cores and stranded wire for the coils enables full advantage to be taken of these good features. Provision is made for initial adjustment of the selectivity, or band width, though the component is not designed to be employed as a variable selectivity IF transformer.

The curves reproduced here were taken with a specimen transformer, the figures against each indicating the measured stage amplification in a test circuit. With minimum coupling the selectivity is more than

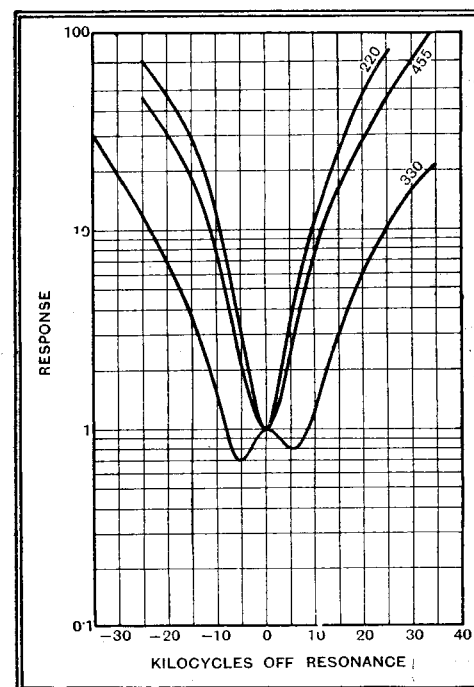

Response curves of Varley Air Tune IF transformer taken at three different settings of the coupling adjuster, viz., loose, medium and tight.

adequate for most purposes, while the stage gain is still exceptionally good.

The full advantage of the high amplification afforded by this transformer can be taken by adopting the usual precautions in screening and decoupling. If two IF stages are employed it might be an advantage to use the tapping on the primary winding.

All the connections are taken to terminals on the base, and for chassis mounting the bent metal bracket could be removed. The price of this component is 15s.

Ullswater Committee's Final Meeting

I UNDERSTAND that the recommendations of the Ullswater Committee in regard to the future of the B.B.C. will be published about the middle of November.

The report is already complete, and every member of the Committee now has a copy to mark, learn, and inwardly digest. Probably next week they will hold their last meeting, at which the final draft will be either accepted or amended. It will then be handed to H.M. Postmaster-General.

General Election Cry?

If the report should see daylight before the General Election it is conceivable that it may offer some good platform planks for speakers on both sides. The time may yet come, of course, when broadcasting will be the basis of an election fight, but not yet. . . .

Radio on the Screen

TECHNICAL howlers were fairly frequent in the early films. The handsome young operator would write down a message received while the sparks spluttered in the gap; while First Lords of the Admiralty would announce that the Secret Service had discovered the exact wavelength between Jutland and the Dogger Bank. (Bravo, boys!)

"Music Hath Charms"

Nowadays one needs a telescopic lens and a deal of imagination to discover flaws in a film dealing with radio. I found none the other evening at the first screening of Henry Hall's new film, "Music Hath Charms," a lively, well-acted, and perfectly photographed narrative concerning the apotheosis of the B.B.C. Dance Band Director.

Henry in the Control Cabinet

At one point Henry, conducting a rehearsal, dashes into the control cabinet adjoining the studio. We, the cinema audience, join him there and note the effect of juggling with the amplifier controls. Undoubtedly, the results are produced simply by altering the gain control on the recording engineer's trolley, but it is easy to believe that Henry is himself doing the trick.

The Crofter's Spcaker

Similarly, there are some clever fading effects when a transportable set is rotated in the action of the play. The sound rises and falls just as if the music were actually proceeding from the set in the picture. An old Highland crofter is seen

Broadcast Brevities

By OUR SPECIAL CORRESPONDENT

using an Amplion curved horn of, I should think, the Ice Age; its thin shriek penetrates the mountain mists and incidentally guides home a pair of lost lovers.

"Music Hath Charms" should be a great box office draw, and, what is not always the case with such films, the audiences will not be disappointed.

Closing Down No. 10

TOMORROW is a solemn day in the annals of Belvedere Road, S.E.1. The shirt fronts of the B.B.C. Dance Band will crackle for the last time in that somewhat gloomy district, for the old wharf studio is to be closed.

"Henry Hall's Hour" tomorrow night will be the last in "No. 10."

Gerald Cock's Choice

It is five and a half years since Gerald Cock chose this, the best studio the B.B.C. has ever possessed. It was on a wet day

physical hunger, when Mr. Cock's eye caught sight of the dingy wharf warehouse, and made up his mind on the spot. The studio was unique for many years in that it was the only one which would accommodate the whole of the B.B.C. Symphony Orchestra as well as an audience of several hundreds.

A Fatality

At times some thousands of pounds worth of band instruments have been stored in a small office off the main studio, but burglary was attempted only once, and then without success. On another occasion a boy fell through the main fanlight and was killed.

Broadcasting a Car Accident

FOR sang froid in tight corners the Norwegian "O.B." men appear to be qualifying for the highest honours of the year. The other day I recorded the exploit of an Oslo radio reporter who con-

was revolving and the man at the mike was able to give a faithful, if flurried, description of this apparent descent to death. Fortunately, the brakes "did their stuff" just in time, the screeching of the brake blocks supplying a fitting conclusion to a most thrilling record.

The car was repaired and eventually reached a height of nearly 7,700 feet, which should be a record for "O.B." vans.

French Listeners and the B.B.C.

FRENCH listeners are, I hear, extraordinarily interested in the news that the B.B.C. Symphony Orchestra will visit Paris to give a concert in the Salle Rameau in April next.

Many provincials are pleading that the concert should be relayed throughout France—a confirmation of the fact that the standard of wireless reception across the Channel is not so high as in Britain. English listeners regularly tune in the French National Orchestra broadcasting from Radio-Paris, but comparatively few French listeners outside the Capital dream of tuning in Droitwich, even in the rare cases where sets are capable of such a feat.

At Grosvenor House

THE B.B.C. Dance Orchestra will provide dance music at the Variety Ball, to be held at Grosvenor House, Park Lane, on November 14th, in aid of the Variety Artists' Benevolent Fund and Institution.

This annual function is the only one at which Henry Hall and the B.B.C. Dance Orchestra personally appear in public to play music for dancing.

Two other well-known broadcasting bands—Mantovani and his Tipica Orchestra and Bobby Howell and his Band—will also play at the Ball.

Night Falls . . .

IT will be a bad day when the B.B.C. can no longer guy its own efforts, but, fortunately, that day seems a long way ahead. On November 4th next Charles Brewer is presenting a satirical play entitled "Night Falls on 'Slow-on-the-Up-take.'" "The cast will include Vivienne Chatterton, Dick Francis, Ernest Selfton, John Rorke, Carleton Hobbs, and Leonard Henry.

It is not yet decided who will take the part of Eric Maschwitz.



HENRY HALL IN CONTROL. An interesting "still" from "Music Hath Charms"—the new film in which Henry Hall and the B.B.C. Dance Orchestra play the leading rôles. In this picture Henry has just dashed into the control cabinet to judge results via loud speaker.

towards the end of the winter of 1929-30 when Mr. Cock, in company with an L.C.C. official, visited various buildings more or less derelict which might be transformed into broadcasting studios. They inspected schools and halls owned by the Council, as well as disused chapels.

Unique Studio

Nothing seemed worth considering, and the pair were experiencing that November gloom which accompanies wet feet and

continued broadcasting when unexpectedly caught up in a maelstrom of reindeer hoves.

Better than this, however, is the adventure of the "O.B." men a fortnight ago when the recording squad set out in a car to climb Norway's highest mountain, the "Galhøpiggen."

Broken Steering Gear

Half-way up the mountain the steering gear broke and the car zigzagged towards a precipice. The recording turntable

Random Radiations

By
"DIALLIST"

A Guarantee Point

IF you should have occasion to return a set to the manufacturers for repair because the local man has found himself unable to deal with the trouble, there are one or two points of real importance that should be borne in mind. First of all, most firms insist that the set should be returned *not* direct but through the local man. Don't therefore send it off yourself. But the afore-mentioned local man is unlikely when he returns the receiver to give a full account of what has happened from the customer's point of view—if he has been unable to cope with the waywardness of the apparatus he clearly won't want to call attention to his own shortcomings. Therefore, it is good policy to write to the manufacturers saying that, in accordance with the guarantee, you have handed set No. so-and-so, Model so-and-so, to X. Y. Z., your local dealer, for return to their service department. Follow this with a description of the trouble experienced and of the steps which the local man took to provide a remedy. If you have just cause for feeling aggrieved, your case is then likely to be treated on its merits, and a satisfactory settlement from the point of view of both sides is more than probable.

Pity the Poor Manufacturer

If you don't write, just imagine what happens when your set is received by the service department accompanied by nothing but the briefest description of the symptoms by the local man. The service department cannot know that the set has perhaps given trouble on several occasions, or that the man from whom you bought it has made abortive attempts to set it right. It can't possibly have any idea that you are annoyed at having been deprived of the use of your set during its visits—some of them possibly of longish duration—to the local workshop. Its point of view is naturally, "Here is a set purchased so many months ago which has only just broken down. It has been returned to us for repairs, and under the terms of the guarantee we undertake to replace faulty components free of charge, but to send in an account for the actual cost of labour." The account, therefore, goes in, and it may be quite a large

one. Had the service department people been in full possession of the facts they would probably have tempered the wind to the shorn lamb, besides possibly hauling over the coals the local man whose incompetence made the return of the set necessary.

Improved Service Needed

The bulk of service men are probably pretty good at their job. They can locate any but the most abstruse faults, and they are capable of removing and replacing components that have proved defective. But, unfortunately, not every man who undertakes the servicing of wireless sets is thoroughly up to his job. I have come across alleged service men—and I have no doubt you have done so as well—whose only equipment for set testing consisted of a screwdriver, a pair of pliers, a cheap volt-meter, and a permanently puzzled expression. So long as these are turned loose on customers to provide the free service offered under the guarantee, dissatisfaction is bound to occur, for they are incapable of doing properly jobs which they undertake to do on behalf of the manufacturers.

There are movements, and pretty successful ones, towards creating a corps of trained service men; but by no means every retailer is willing to submit himself or his assistants for a course of instruction. Were I a radio manufacturer I would refuse to give an agency for my products to any retailer who could not produce satisfactory evidence either that he was himself skilled in wireless repair work or that he employed a man capable of doing such jobs as might come his way.

Something Like a Set

SOME time ago it was reported that the Radio Corporation of America was to spend a million dollars upon television research and development. The latest reports from the States indicate that a variety of experimental models of sound and vision receivers have been constructed, and that from these the commercial types will eventually be evolved. The de luxe model, which will presumably be an all-wave wireless set as well as a receiver for sound and vision, is likely to contain 51 (yes, fifty-one!) valves in addition to the cathode-ray tube. That seems to me to be something like a wireless set. The only snag is the consumption, which is estimated at 700 watts.

NEW TRANSATLANTIC TELEPHONY SERVICE.

With the opening of a new commercial telephony station at Lyngby, Denmark increases her means of overseas communication.

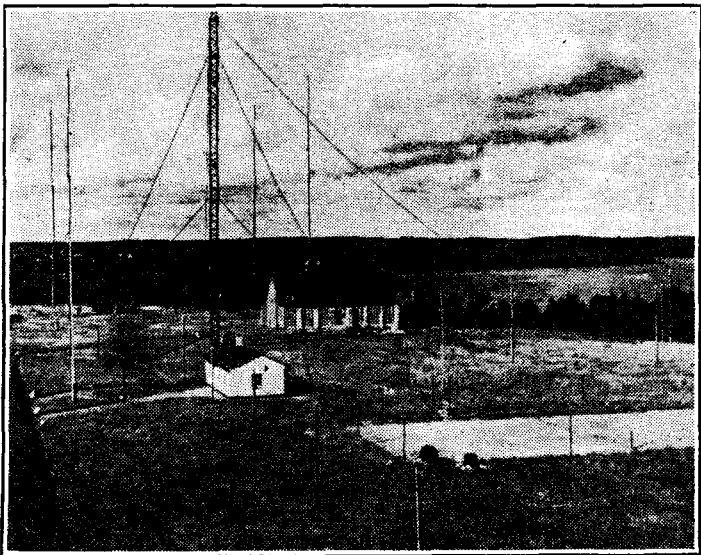

Have You a Hopper Upper?

THE United States is the birthplace of many new words, and its contributions to the vocabulary of wireless have been by no means small. Some of these words, and in particular names for components and small bits and pieces, are adopted over here, often without any particular rhyme or reason. Why, for instance, should we speak of a hum-bucking coil? The name is utterly meaningless in English, for with us "buck" as a verb has only one meaning—what a horse does when he desires to intimate that he particularly dislikes your presence on his back. In America "to buck" means to baulk or prevent. Why we shouldn't call such a coil a hum-stopper I really can't say.

I only hope that we shan't adopt the latest American wireless name, the hopper upper. To hop up a set is, in American radio jargon, to provide it with a short-wave converter, and a hopper upper is nothing more or less than such a converter.

Sound-proof Houses

LIKE myself, many readers were probably very interested in the recent announcement by Dr. R. E. Stradling, Director of Building Research in the Department of Industrial and Scientific Research, that much work was being done with a view to making the interiors of houses proof against sounds from outside. There is no doubt that the general noise level of our towns has risen very much during the past twenty years, and, sad as I am to have to say it, I fear that the loud speaker has made its contribution. In blocks of flats or semi-detached houses of somewhat sketchy construction the noise of the next door loud speaker can be something more than a nuisance. One flat dweller is said to have complained of the noise made by his neighbour when eating celery! What a joy a sound-proof house would be in these days of noise and racket.

The Little Show

MANY readers, I am sure, welcomed the cabaret feature entitled "The Little Show," which made its first appearance in the middle of October. I have often felt that those who had to work until a latish hour in the evening had rather a thin time from the Home stations unless they were content with nothing but dance music programmes. "The Little Show" is a late night feature made up mainly of items by artistes who are actually appearing in cabaret shows in London hotels and restaurants. Those who must perforce return home late in the evening can thus look forward to hearing the turns that they would have seen for themselves had they been supping in the West-end.

One little point rather puzzled me in the B.B.C.'s first announcement of this item. It stated that amongst those included in the cast would be Marie Roland and her Tyroleans. "They are reputed to be the finest yodellers who have ever crossed from Germany." Germany? I had an idea that the Tyrol was Austrian and that yodelling was a speciality of the Austrians and Swiss.